

MATRICE/DIES

- C45 zušlechtěná/quenched
- 42CrMo4
- C45

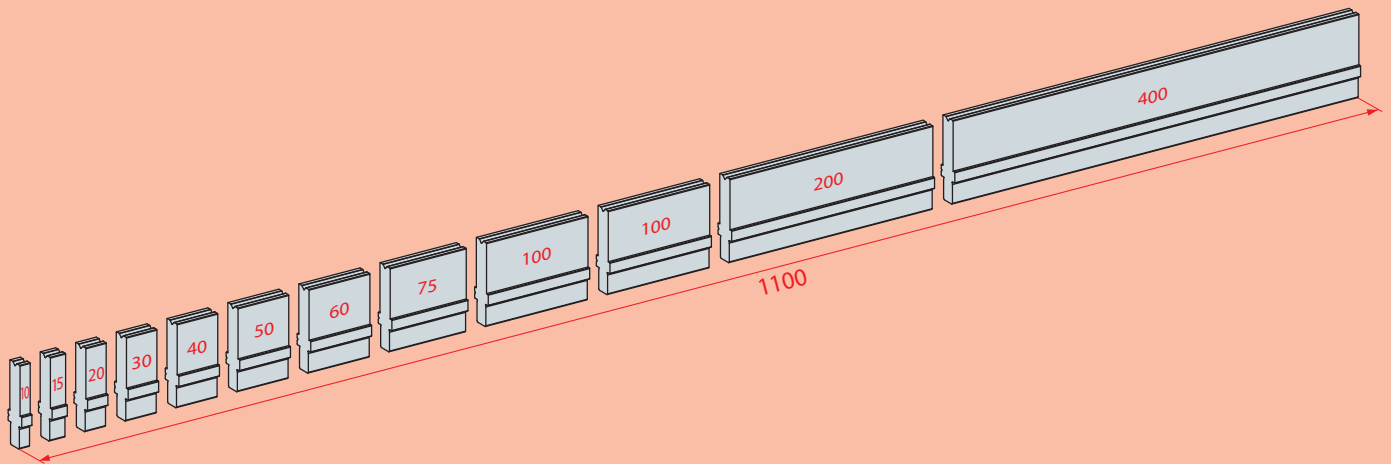
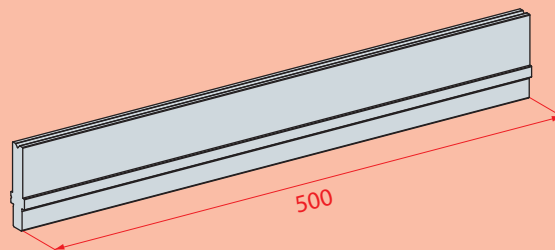
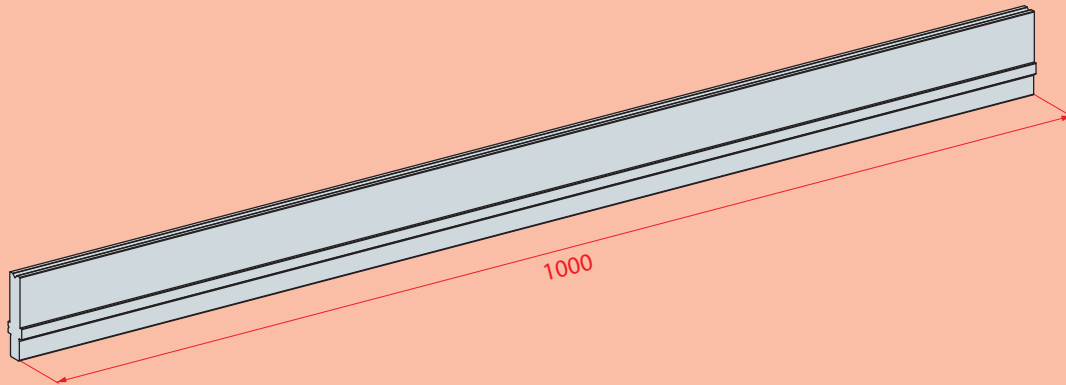

STANDARDNÍ DĚLENÍ/
STANDARD SECTIONING

MATRICE 1V - 88° / SINGLE MATRICE - V - 88°

- C45 zušlechtěná/quenched
- 42CrMo4
- C45

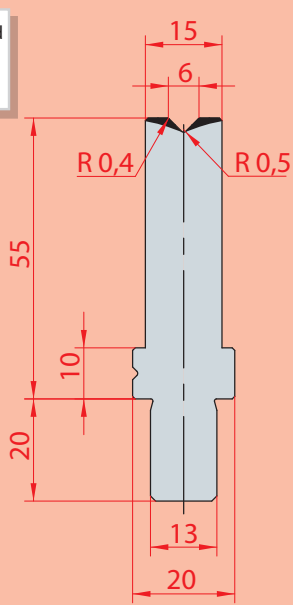

3241
Max T/m=100

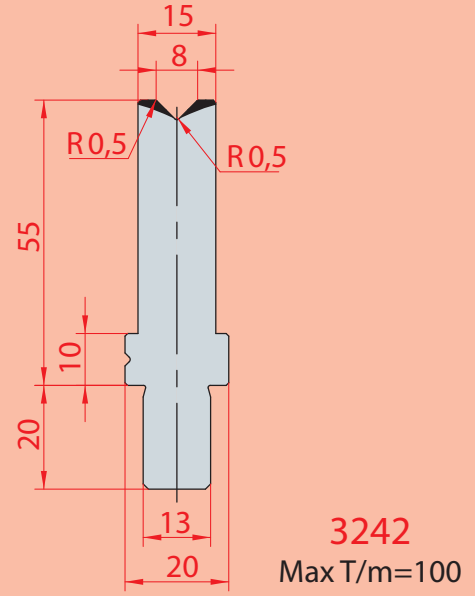

3242
Max T/m=100

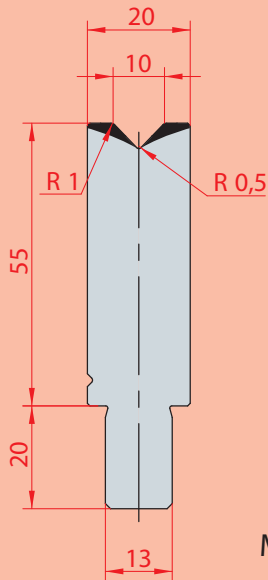

3106
Max T/m=100

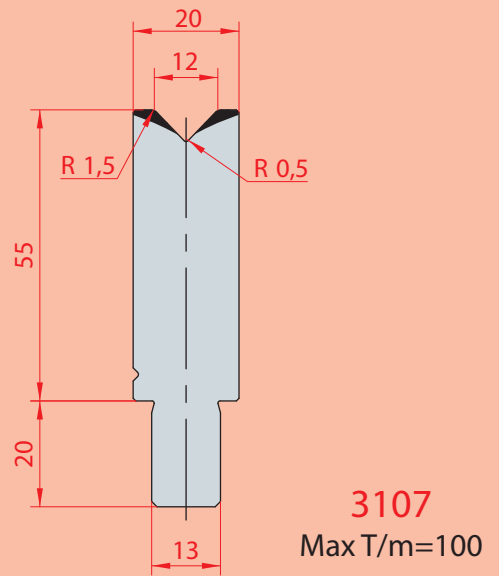

3107
Max T/m=100

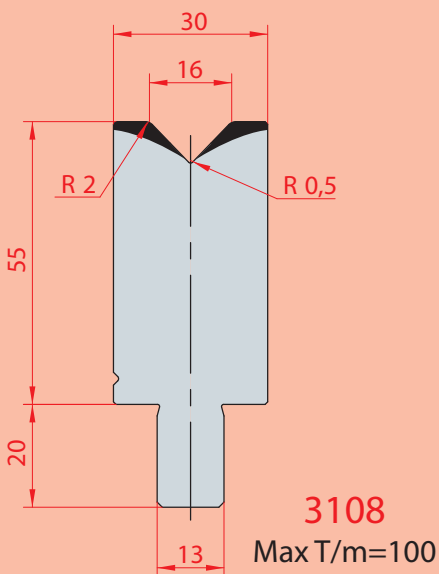

3108
Max T/m=100

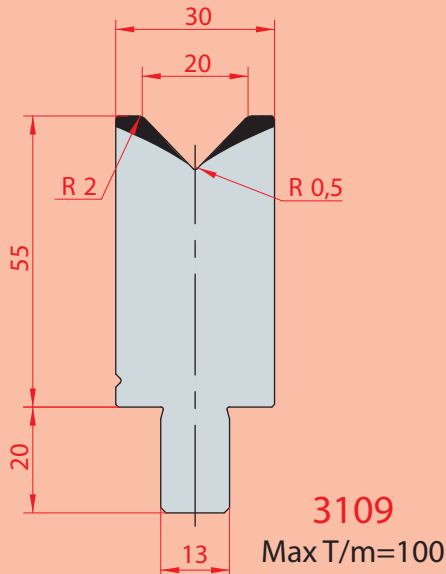

3109
Max T/m=100

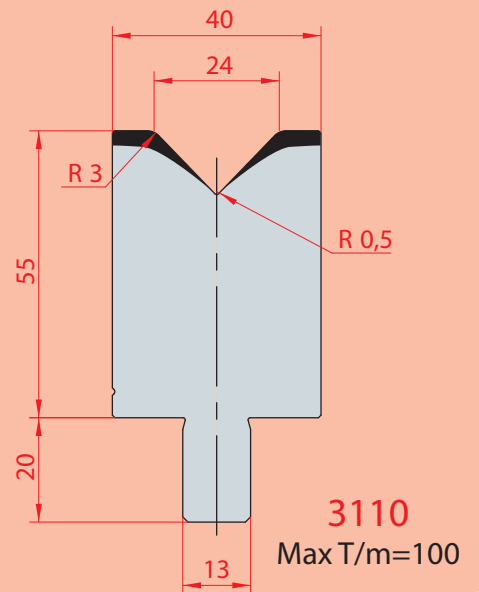

3110
Max T/m=100

MATRICE 1V - 85° / SINGLE MATRICE - V - 85°

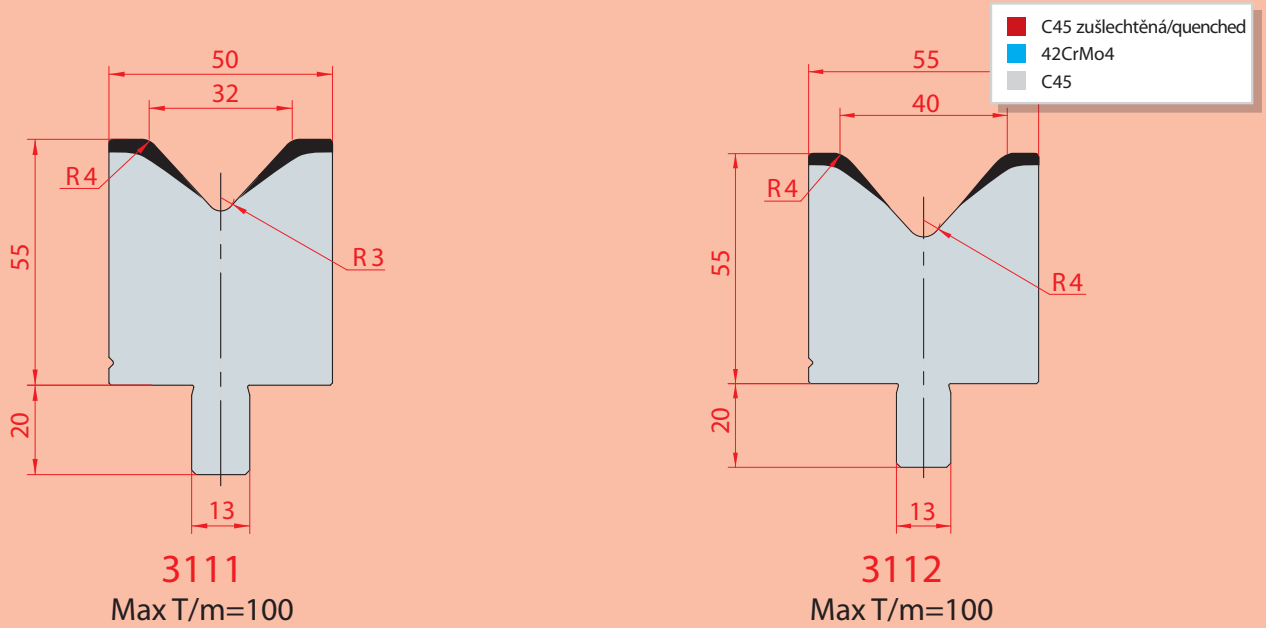

MATRICE 1V - 60° / SINGLE MATRICE - V - 60°

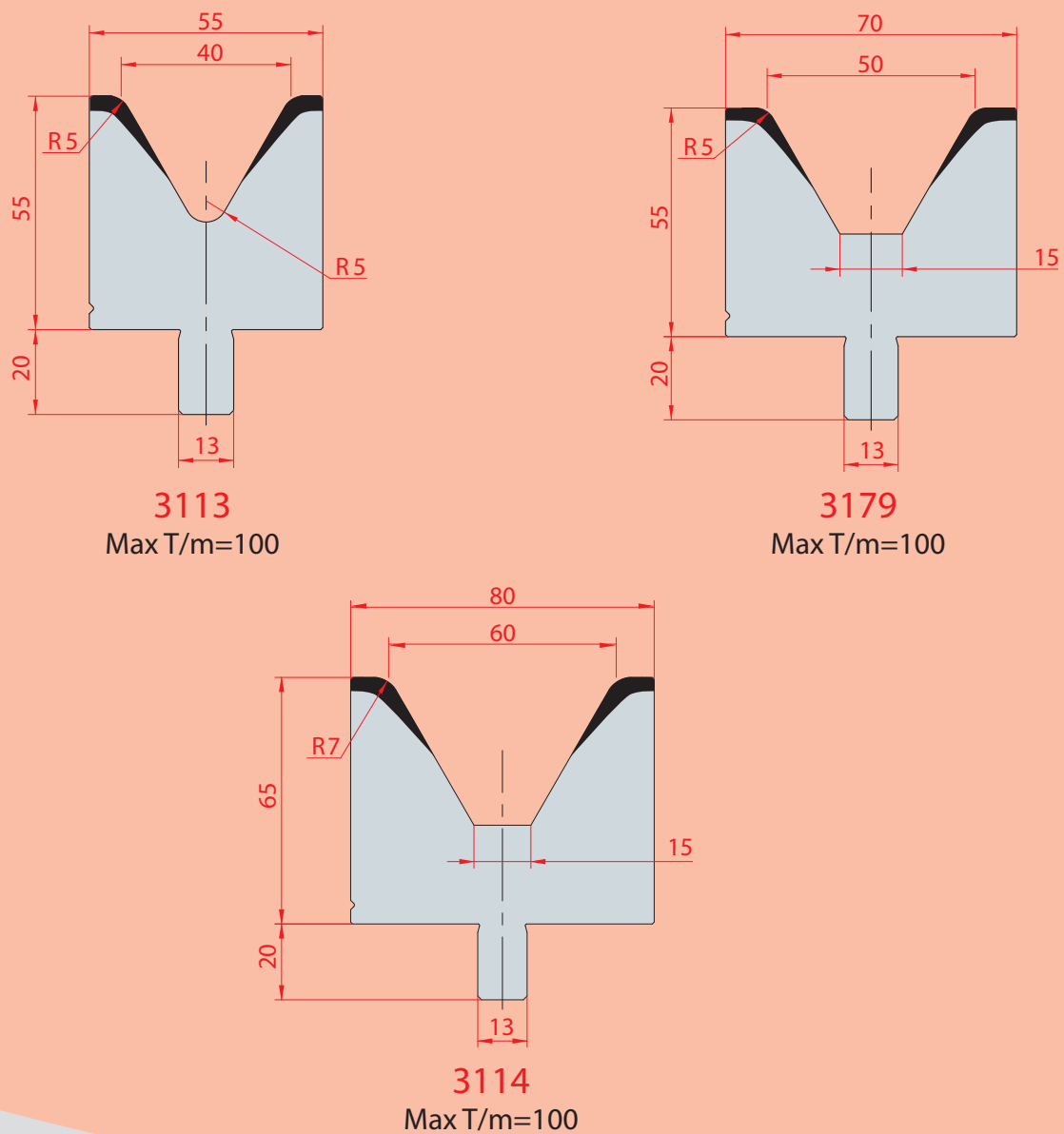

MATRICE 1V - 30° / SINGLE MATRICE - V - 30°

- C45 zušlechtěná/quenched
- 42CrMo4
- C45

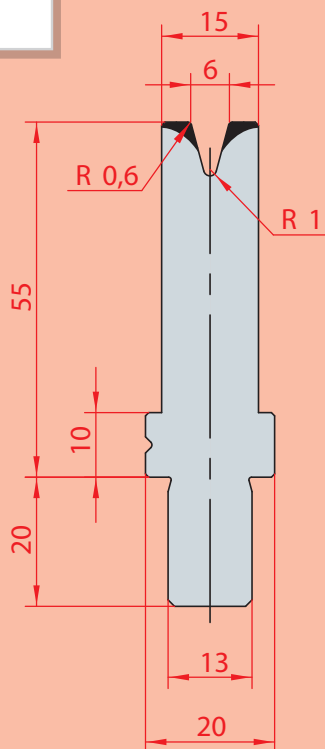

3115
Max T/m=35

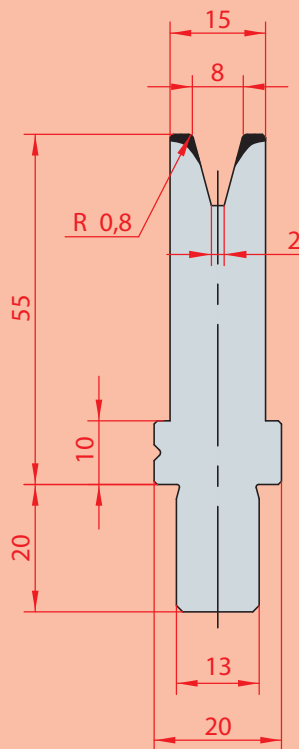

3116
Max T/m=40

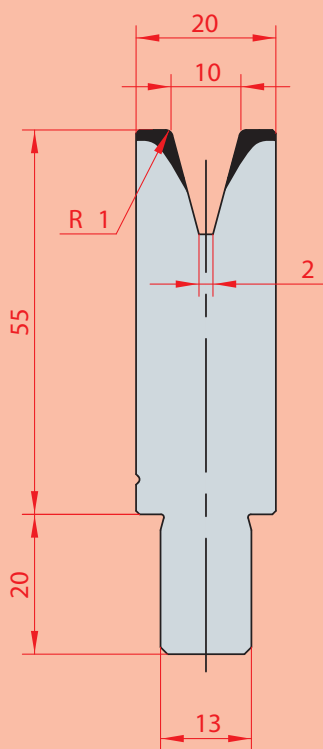

3117
Max T/m=50

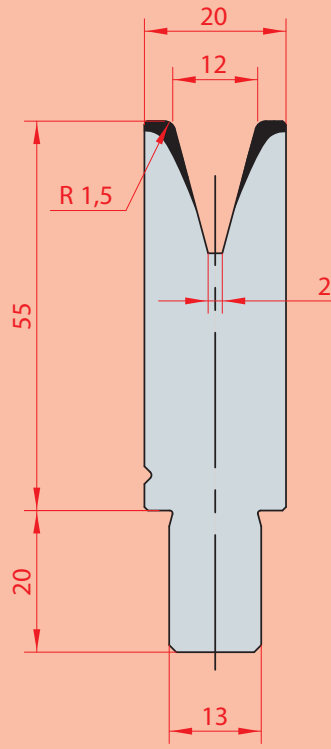

3118
Max T/m=40

MATRICE 1V - 30° / SINGLE MATRICE - V - 30°

■	C45 zušlechtěná/quenched
■	42CrMo4
■	C45

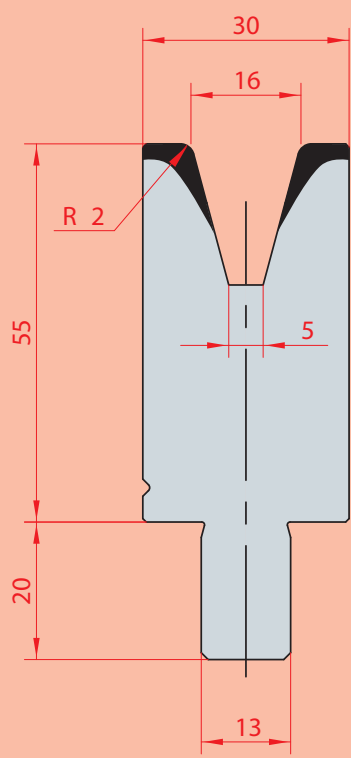

3119
Max T/m=50

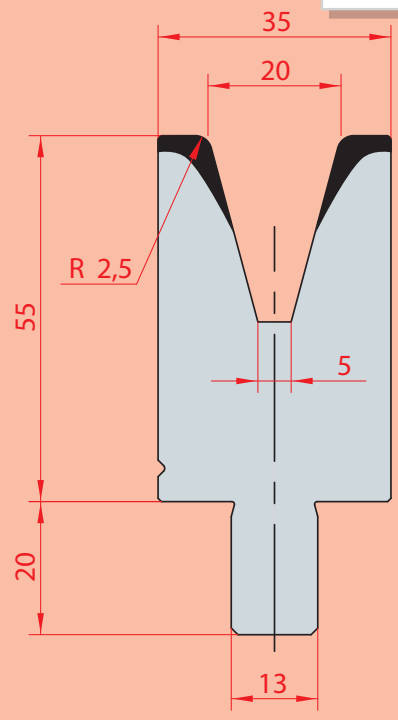

3120
Max T/m=55

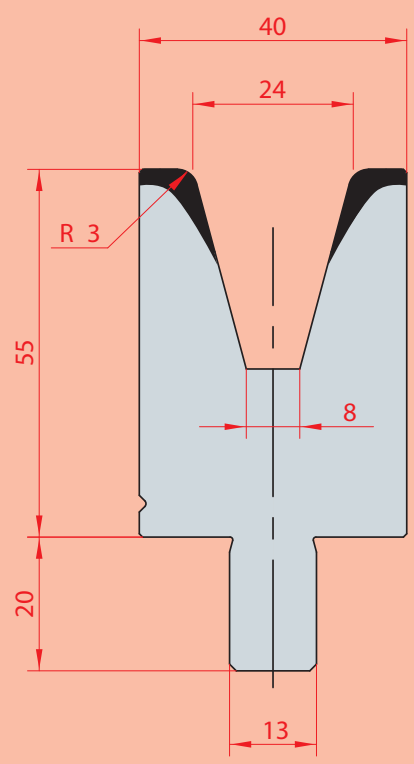

3121
Max T/m=65

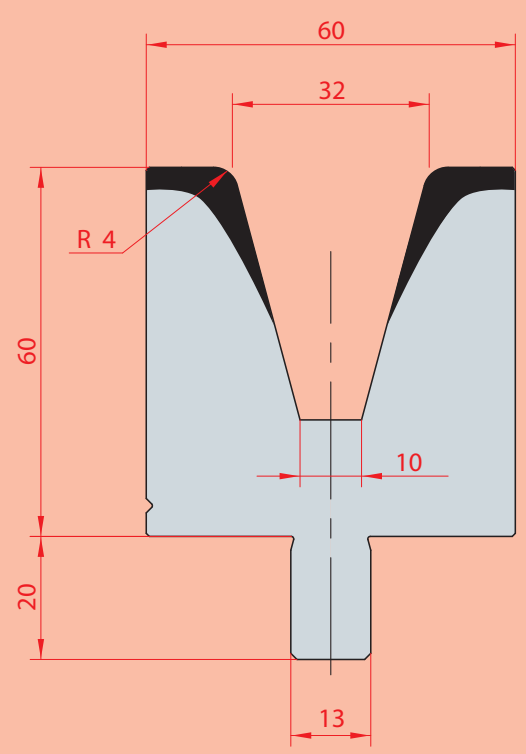

3122
Max T/m=65