

MATRICE/DIES

- C45 zušlechtěná/quenched
- 42CrMo4
- C45

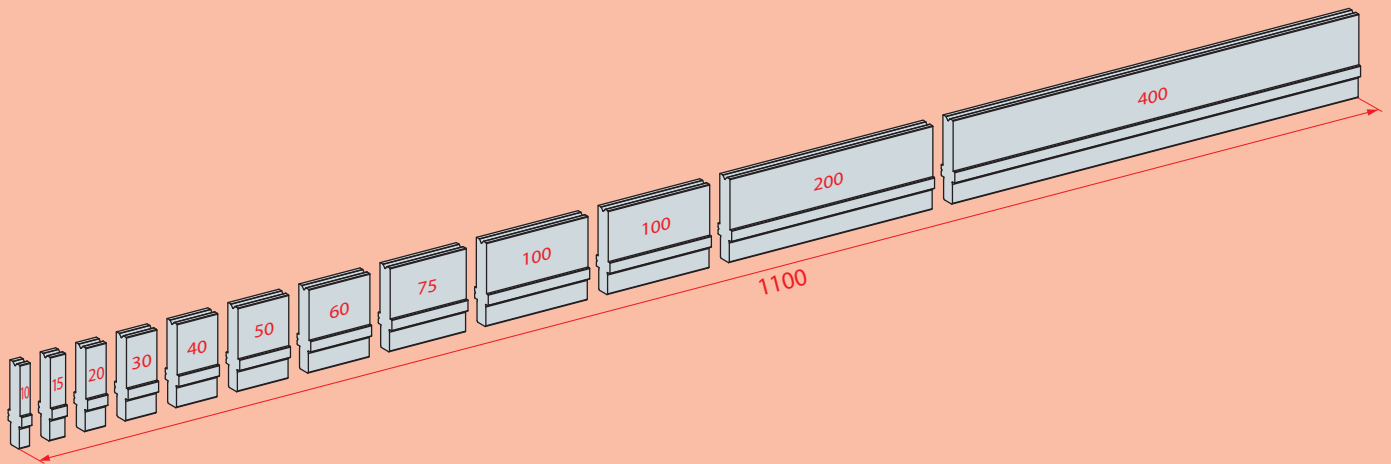
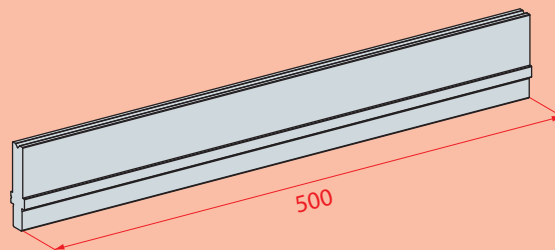
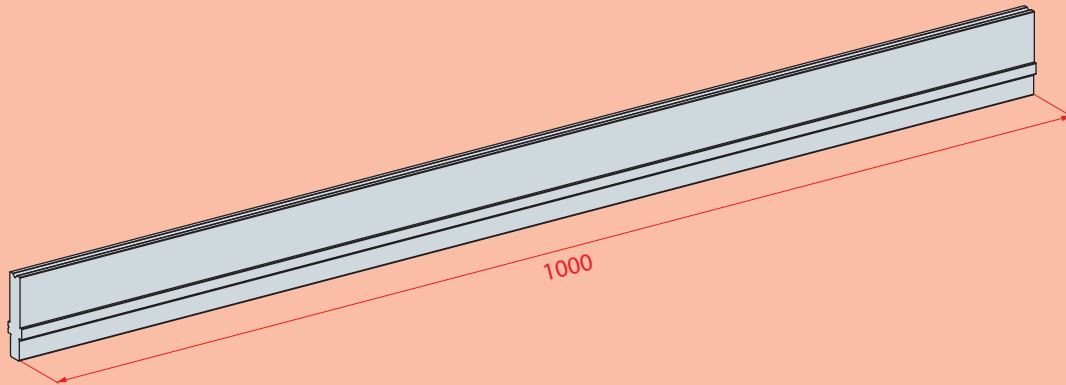

STANDARDNÍ DĚLENÍ/  
STANDARD SECTIONING

PERTLOVACÍ NÁSTROJE / FLATTENING-HEMMING TOOLS

- C45 zušlechtěná/quenched
- 42CrMo4
- C45

500-550 Dělení (Zušlechtěná) / Sectioned (Quenched)

**1252**

Max T/m=80

pro ocel o maximální tloušťce (Černý plech) 1,2 mm  
max sheet thickness mild steel 1,2 mm

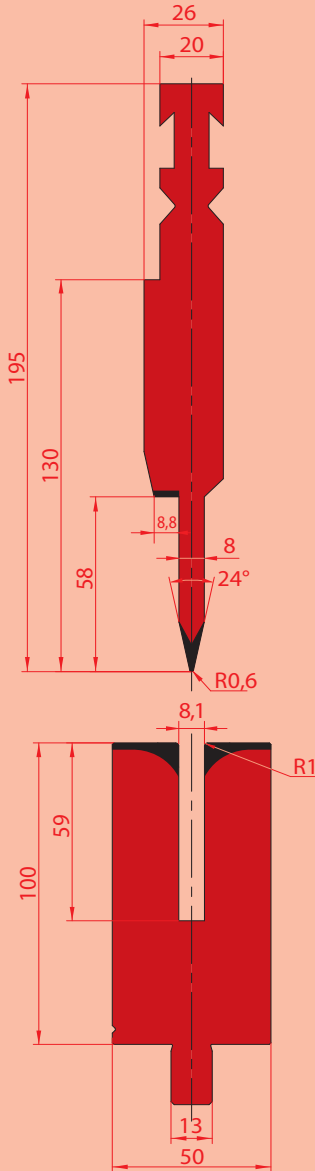

**1253**

Max T/m=80

pro ocel o maximální tloušťce (Černý plech) 1,5 mm  
max sheet thickness mild steel 1,5 mm

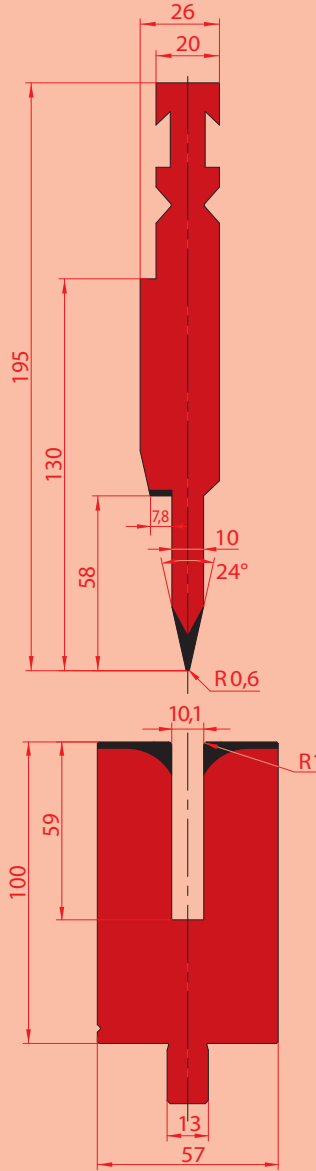

**1254**

Max T/m=80

pro ocel o maximální tloušťce (Černý plech) 1,5 mm  
max sheet thickness mild steel 1,5 mm

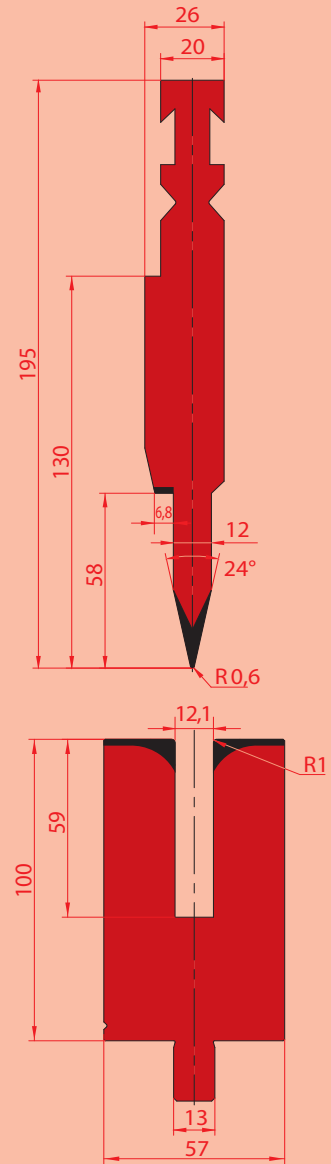

**3157**

Max T/m=50

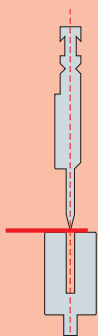

**3174**

Max T/m=50

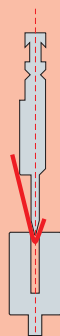

**3175**

Max T/m=50

