

RAZNÍK/PUNCHES

- C45 zušlechtěná/quenched
- 42CrMo4
- C45

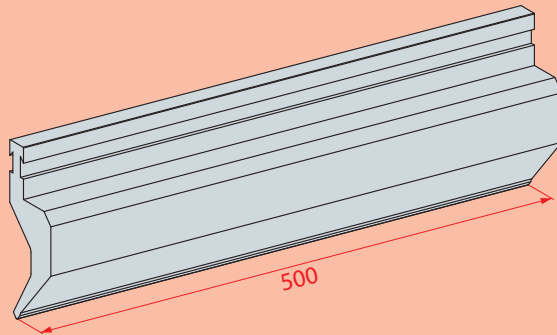

STANDARDNÍ DĚLENÍ/
STANDARD SECTIONING

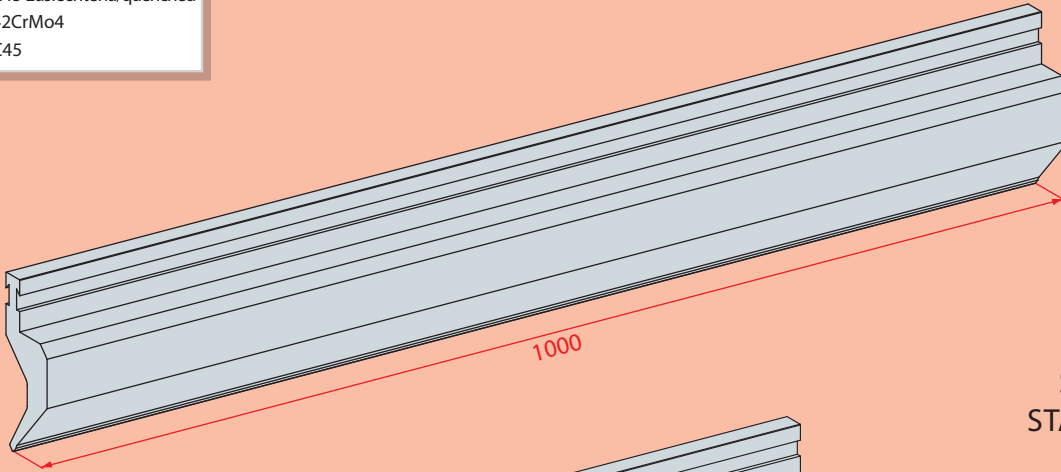
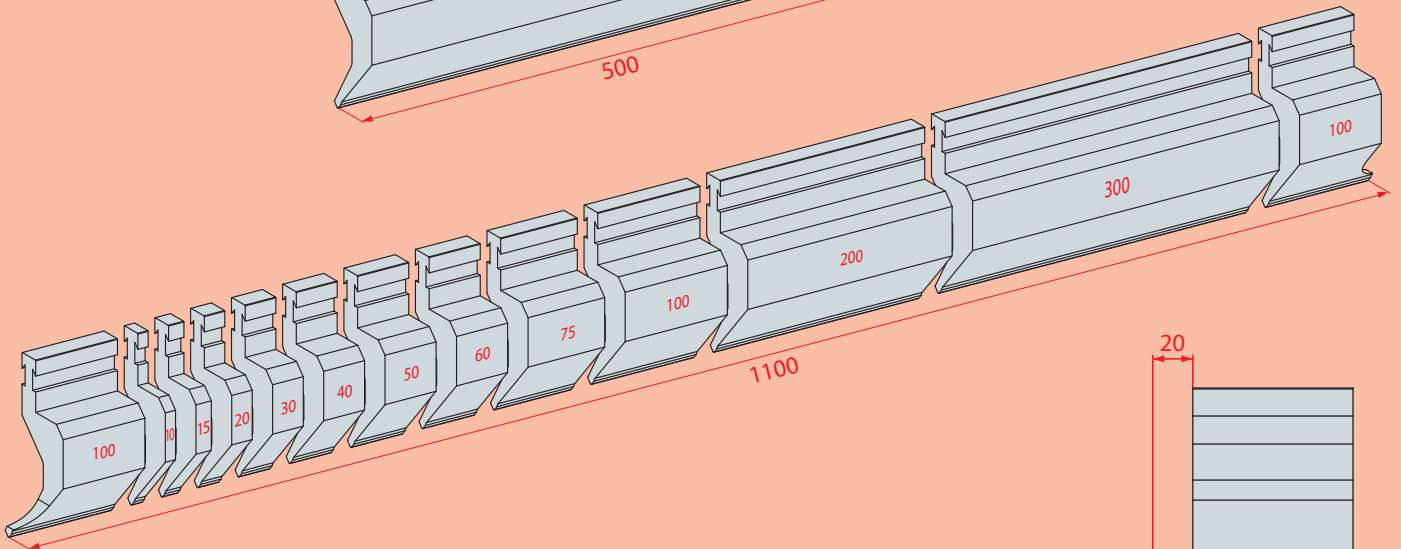

POHYBLIVÉ ROHY
MILLING HORN

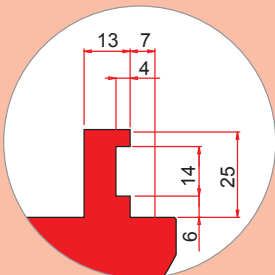
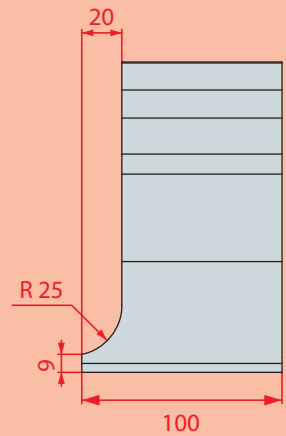

EURO BEYELER
strana / page 87

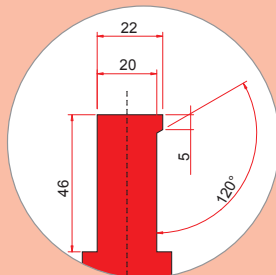

BEYELER S
strana / page 89

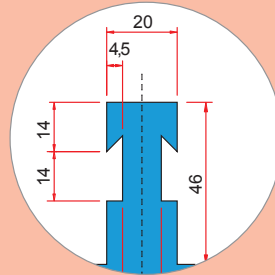

EURO BEYELER R
strana / page 90

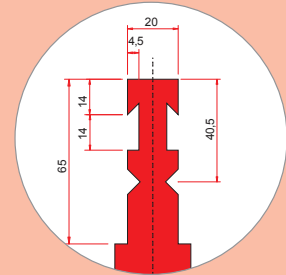

BEYELER RF-A
strana / page 93

VÝROBA RAZNÍKU NA ZAKÁZKU/OUT OF PRODUCTION PUNCHES

na vyžádání / available on request

- C45 zušlechtěná/quenched
- 42CrMo4
- C45

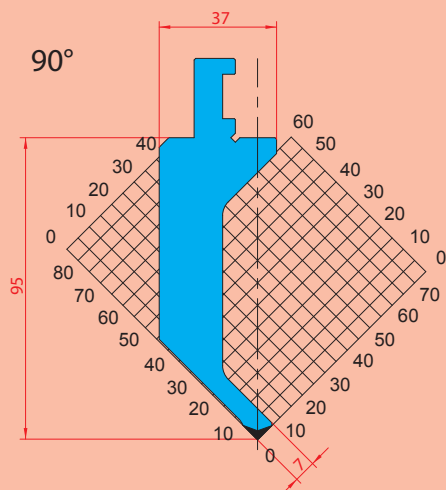

1201

$\alpha=90^\circ$ R=0.6 H=95.00 Max T/m=20

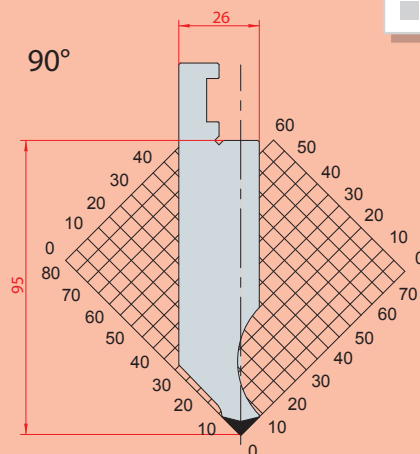

1202

$\alpha=90^\circ$ R=0.8 H=95.00 Max T/m=100

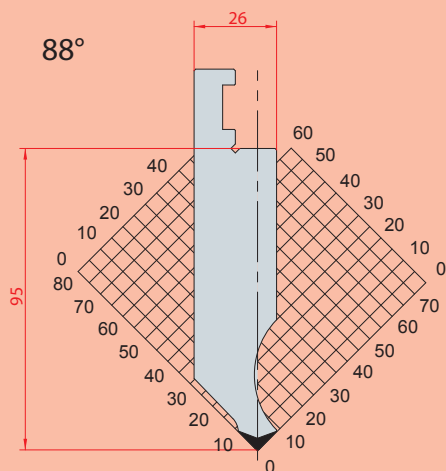

1203

$\alpha=88^\circ$ R=0.8 H=95.00 Max T/m=100

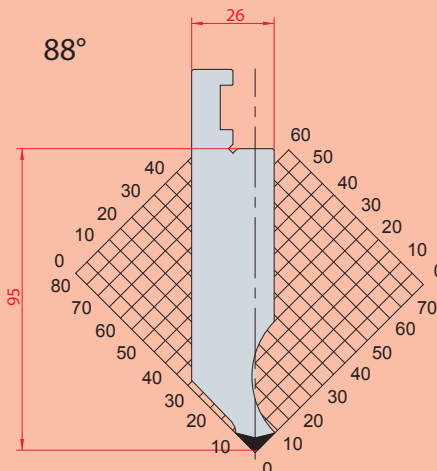

1204

$\alpha=88^\circ$ R=2 H=95.00 Max T/m=100

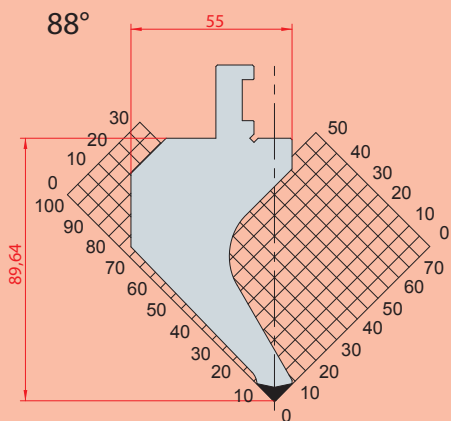

1205

$\alpha=88^\circ$ R=0.8 H=89.64 Max T/m=60

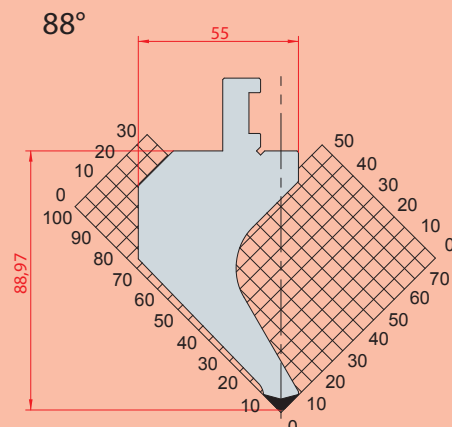

1206

$\alpha=88^\circ$ R=2 H=88.97 Max T/m=60

VÝROBA RAZNÍKU NA ZAKÁZKU/OUT OF PRODUCTION PUNCHES

na vyžádání / available on request

- C45 zušlechtěná/quenched
- 42CrMo4
- C45

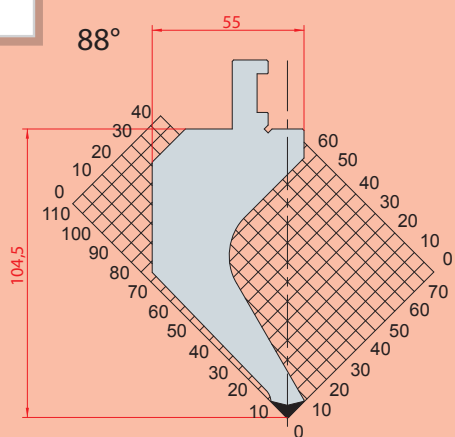

1207
 $\alpha=88^\circ$ R=0.8 H=104.50 Max T/m=50

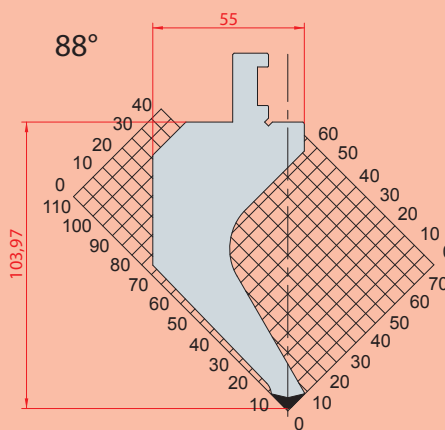

1208
 $\alpha=88^\circ$ R=2 H=103.97 Max T/m=50

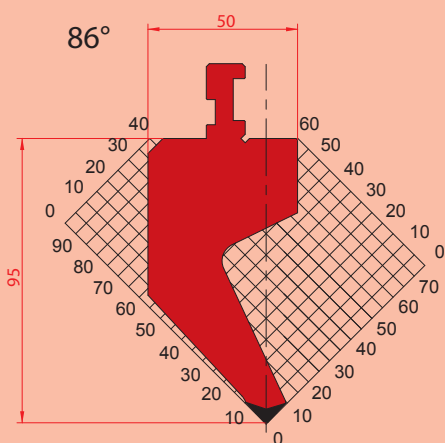

1285
 $\alpha=86^\circ$ R=1 H=95.00 Max T/m=100

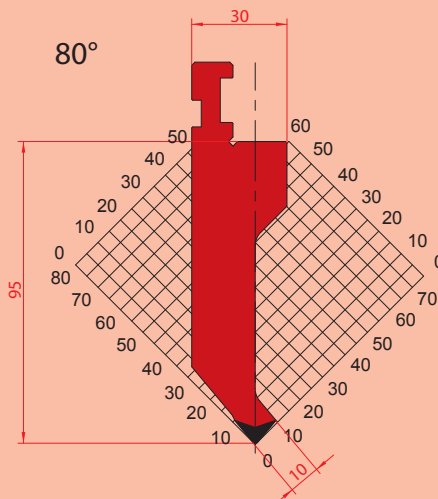

1286
 $\alpha=80^\circ$ R=1 H=95.00 Max T/m=100

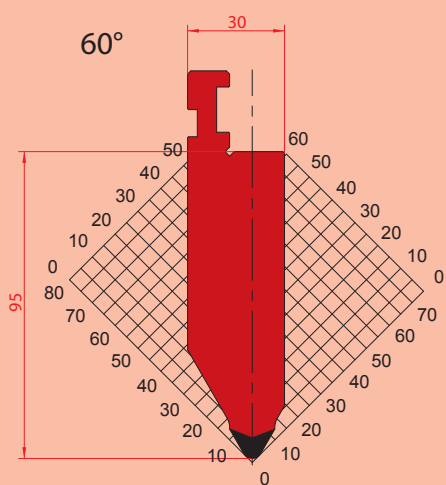

1287
 $\alpha=60^\circ$ R=3 H=95.00 Max T/m=100

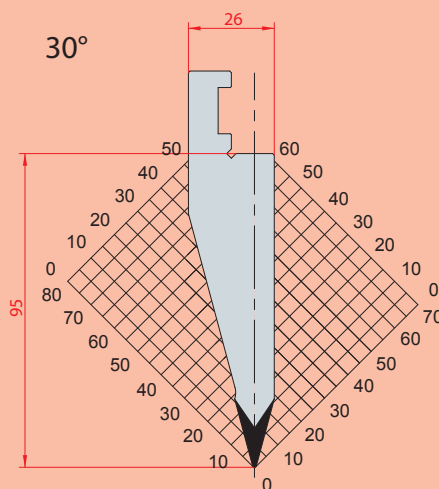

1209
 $\alpha=30^\circ$ R=0.6 H=95.00 Max T/m=100

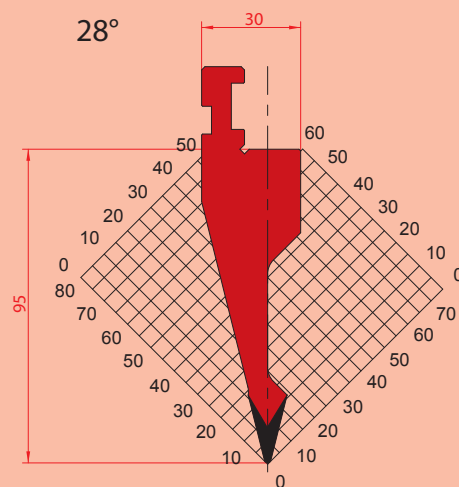

1288
 $\alpha=28^\circ$ R=1 H=95.00 Max T/m=70

VÝROBA RAZNÍKU NA ZAKÁZKU/OUT OF PRODUCTION PUNCHES

na vyžádání / available on request

	C45 zušlechťená/quenched
	42CrMo4
	C45

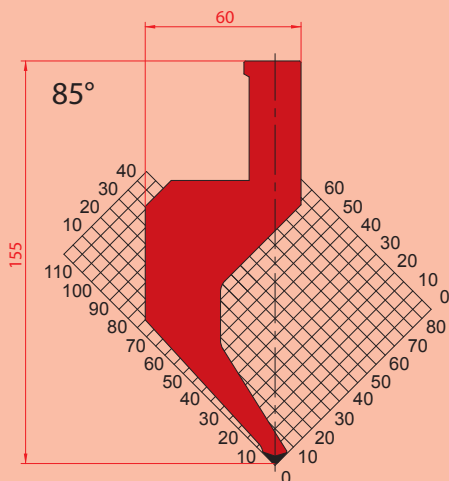

1210

$\alpha=85^\circ$ R=1.5 H=155.00 Max T/m=50

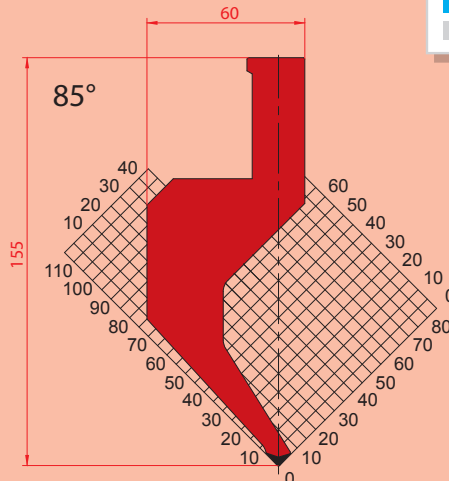

1211

$\alpha=85^\circ$ R=0.8 H=155.00 Max T/m=50

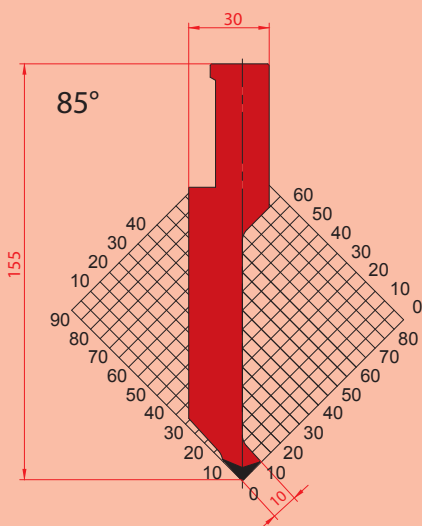

1212

$\alpha=85^\circ$ R=1 H=155.00 Max T/m=100

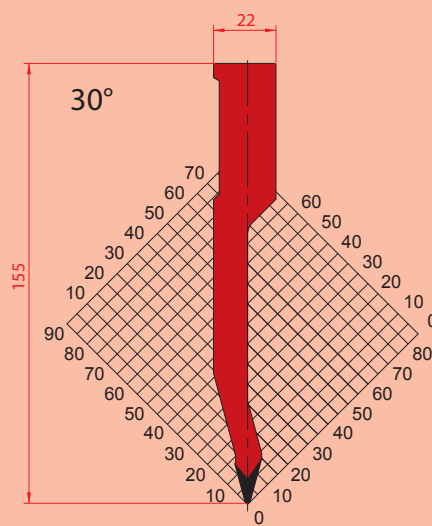

1213

$\alpha=30^\circ$ R=1 H=155.00 Max T/m=80

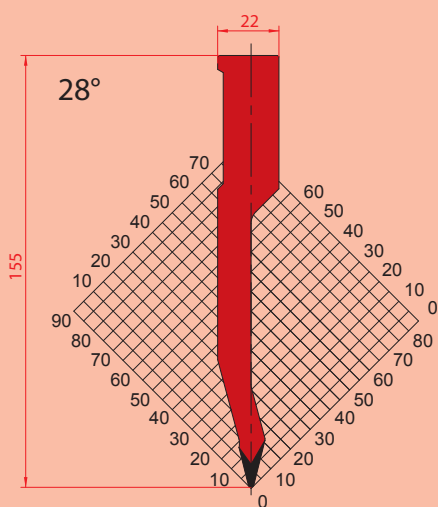

1214

$\alpha=28^\circ$ R=1 H=155.00 Max T/m=80

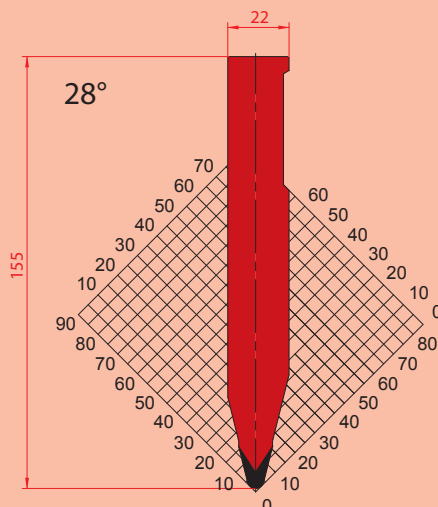

1215

$\alpha=28^\circ$ R=3 H=155.00 Max T/m=100

RAZNÍK - 86° / PUNCHES - 86°

- C45 zušlechtěná/quenched
- 42CrMo4
- C45

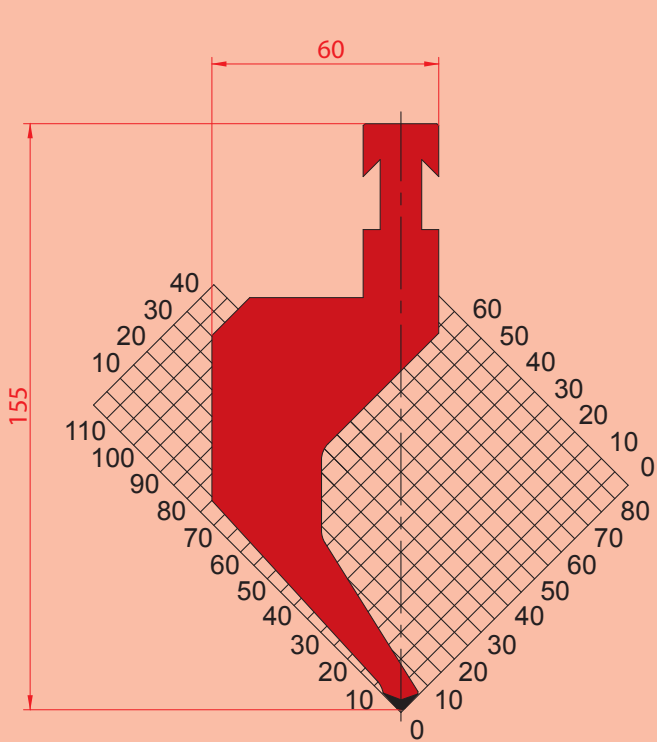
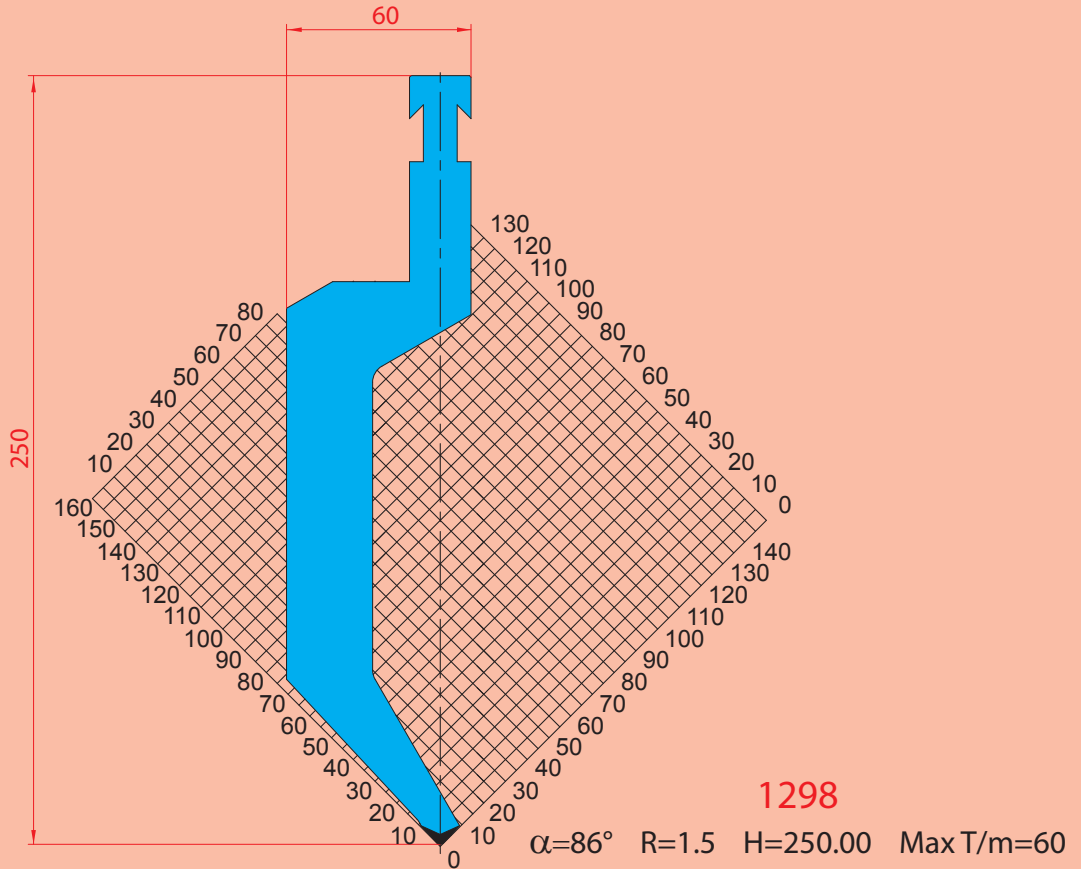

1216
 $\alpha=85^\circ$ R=1.5 H=155.00 Max T/m=50

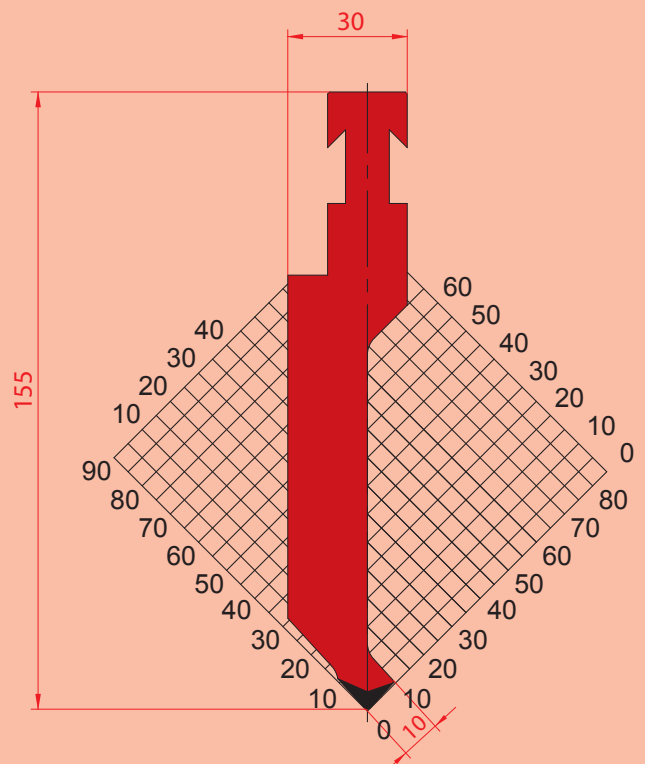

1218
 $\alpha=85^\circ$ R=1 H=155.00 Max T/m=100

RAZNÍK - 30° / PUNCHES - 30°

■ C45 zušlechtěná/quenched
■ 42CrMo4
■ C45

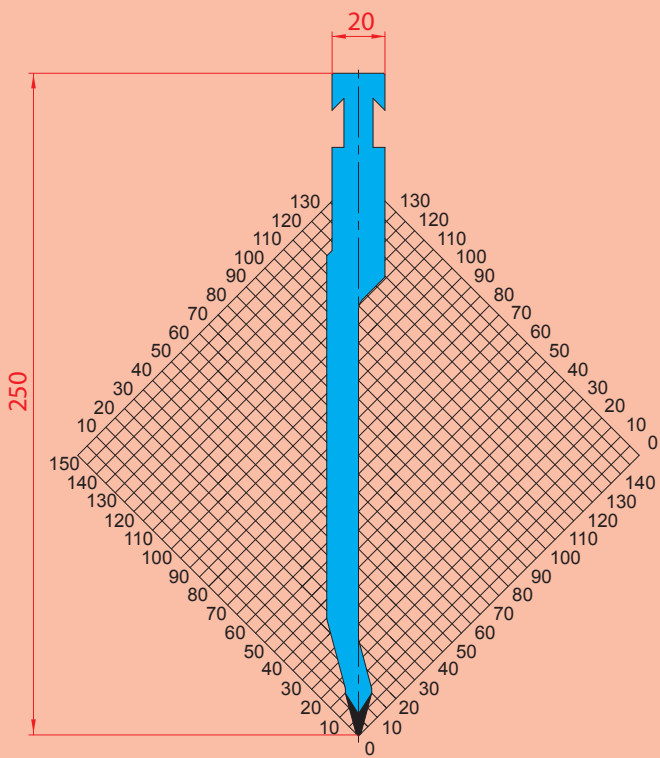

1299

$\alpha=30^\circ$ R=1 H=250.00 Max T/m=80

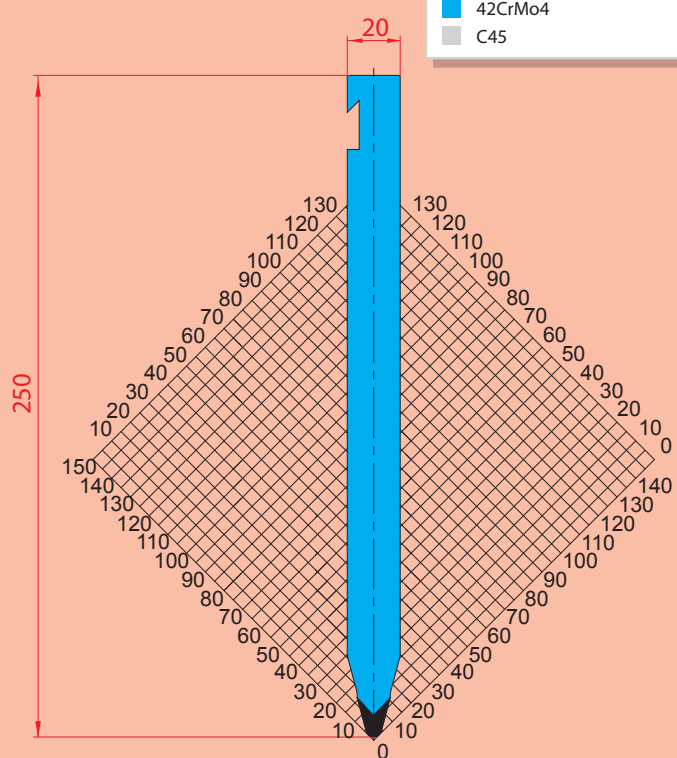

1300

$\alpha=30^\circ$ R=3 H=250.00 Max T/m=120

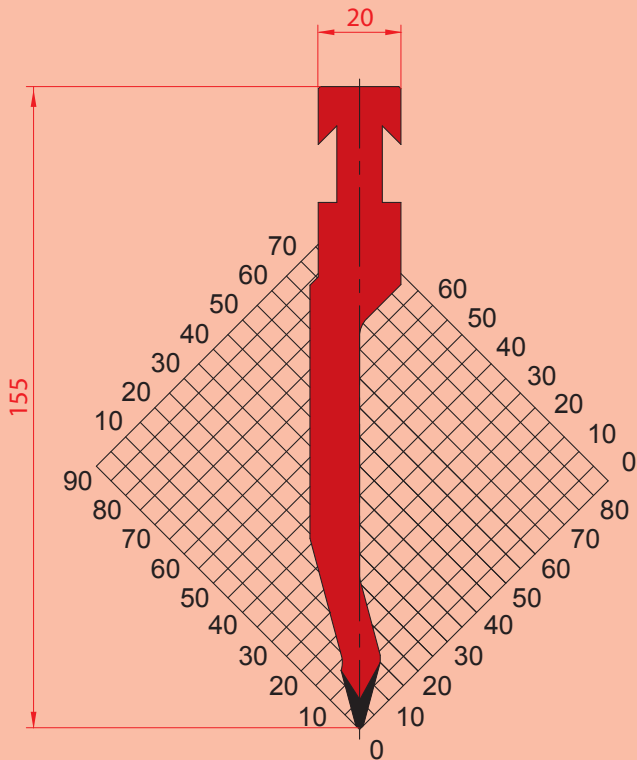

1220

$\alpha=30^\circ$ R=1 H=155.00 Max T/m=80

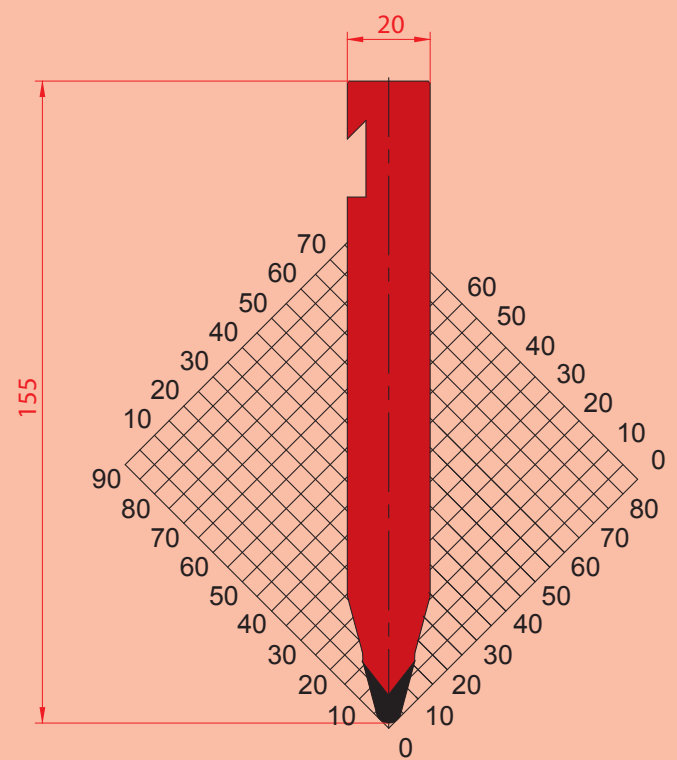

1225

$\alpha=30^\circ$ R=3 H=155.00 Max T/m=100

RAZNÍK - 30° / PUNCHES - 30°

- C45 zušlechtěná/quenched
- 42CrMo4
- C45

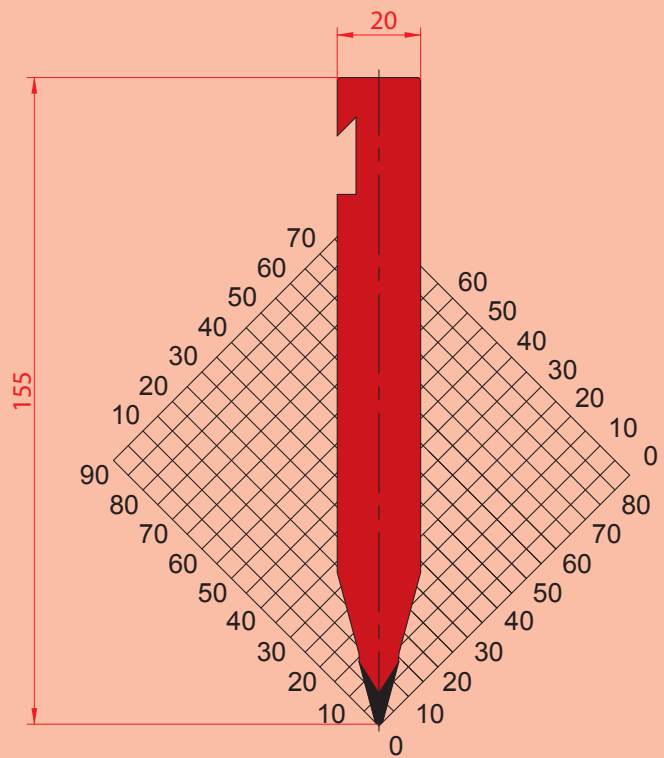

1226

$\alpha=30^\circ$ R=1 H=155.00 Max T/m=100

RAZNÍK - 28° / PUNCHES - 28°

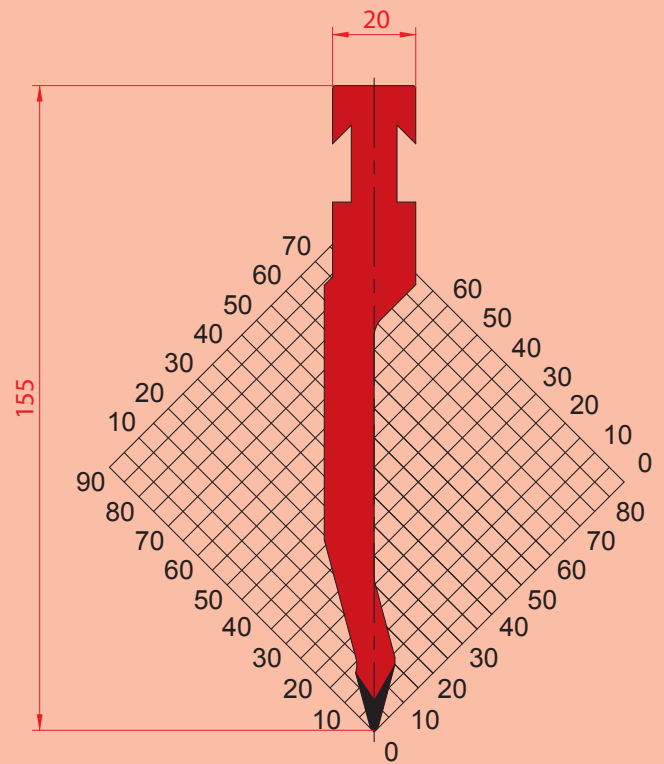

1221

$\alpha=28^\circ$ R=1 H=155.00 Max T/m=80

RAZNÍK - 88° / PUNCHES - 88°

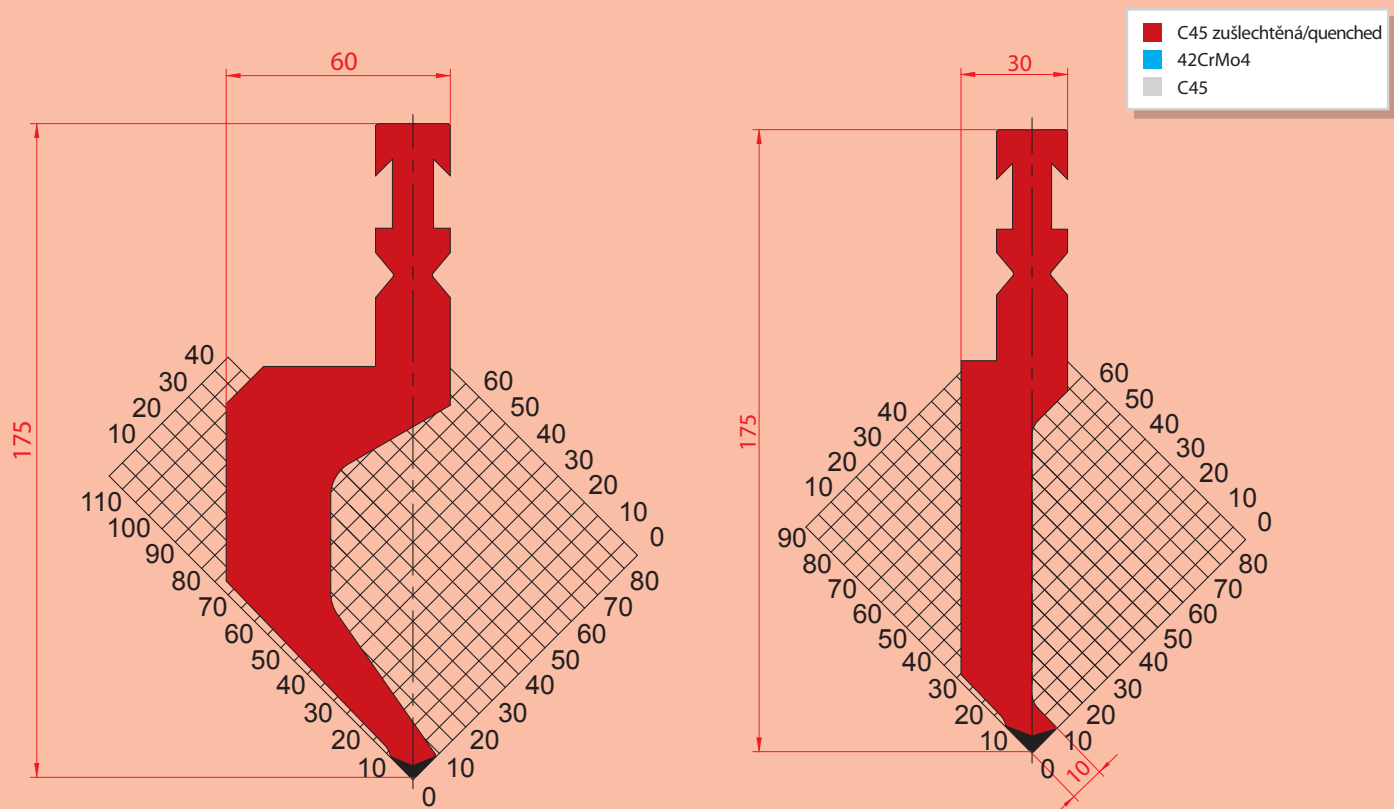

1227

$\alpha=88^\circ$ R=1.5 H=175.00 Max T/m=50

1229

$\alpha=88^\circ$ R=1 H=175.00 Max T/m=100

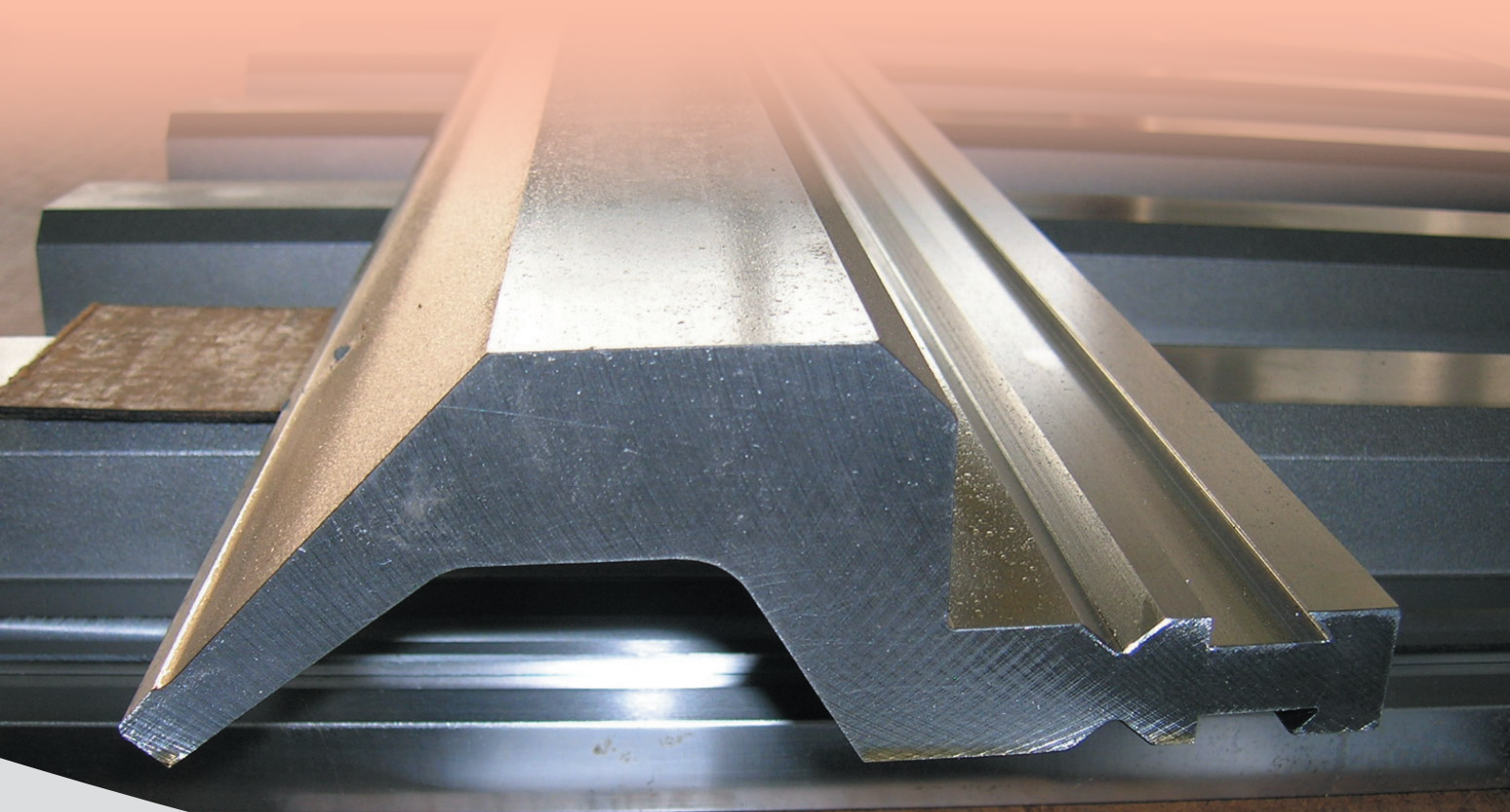

RAZNÍK - 30° / PUNCHES - 30°

- C45 zušlechtěná/quenched
- 42CrMo4
- C45

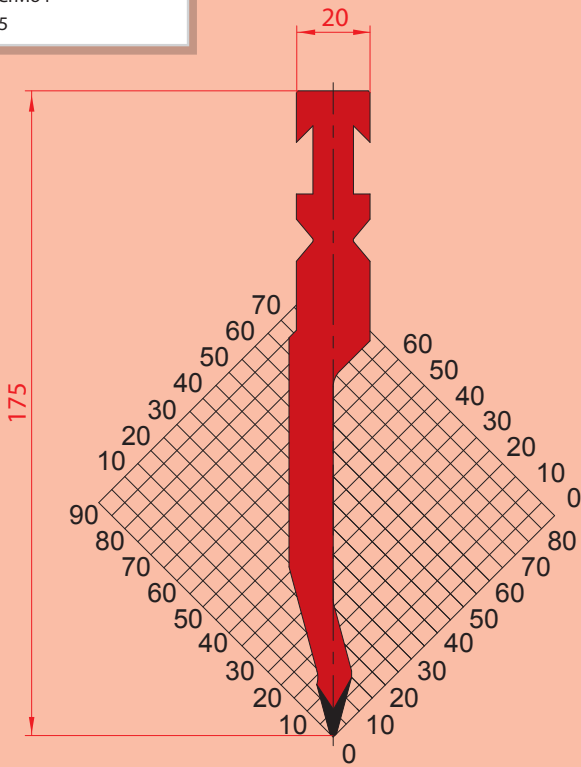

1230

$\alpha=30^\circ$ R=1 H=175.00 Max T/m=80

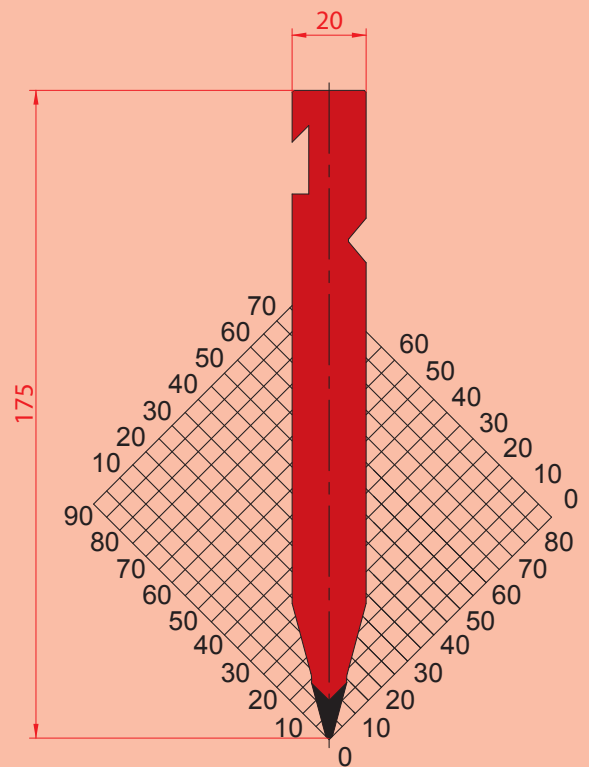

1232

$\alpha=30^\circ$ R=1 H=175.00 Max T/m=100

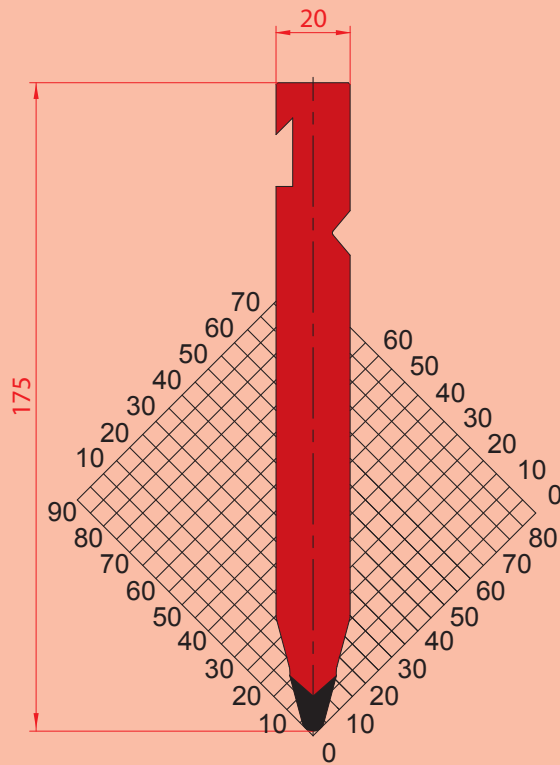

1231

$\alpha=30^\circ$ R=3 H=175.00 Max T/m=100