

DRŽÁKY MATRIC / DIES HOLDER

- C45 zušlechťená/quenched
- 42CrMo4
- C45

PODLOŽKY PRO NASTAVITELNÉ MATRICE
MODELS FOR ADJUSTABLE DIES

kód 9015 1000 mm
PRO MATRICE/for die 3190

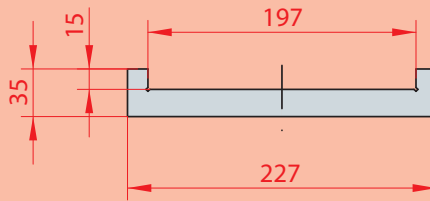

kód 9016 1000 mm
PRO MATRICE/for die 3191

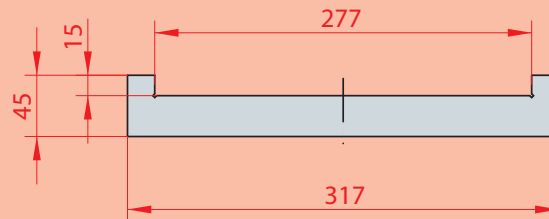

kód 9014 1000 mm
PRO MATRICE/for die 3192

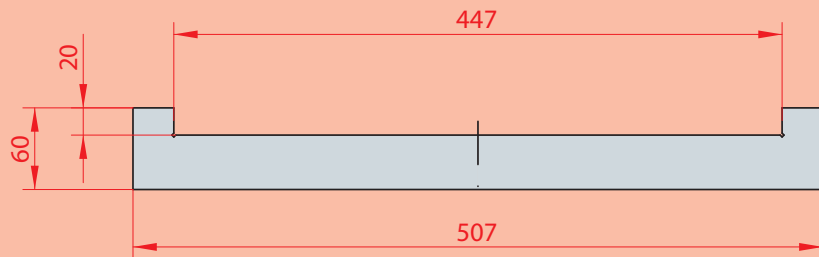

kód 9017 1000 mm
PRO MATRICE/for die 3193

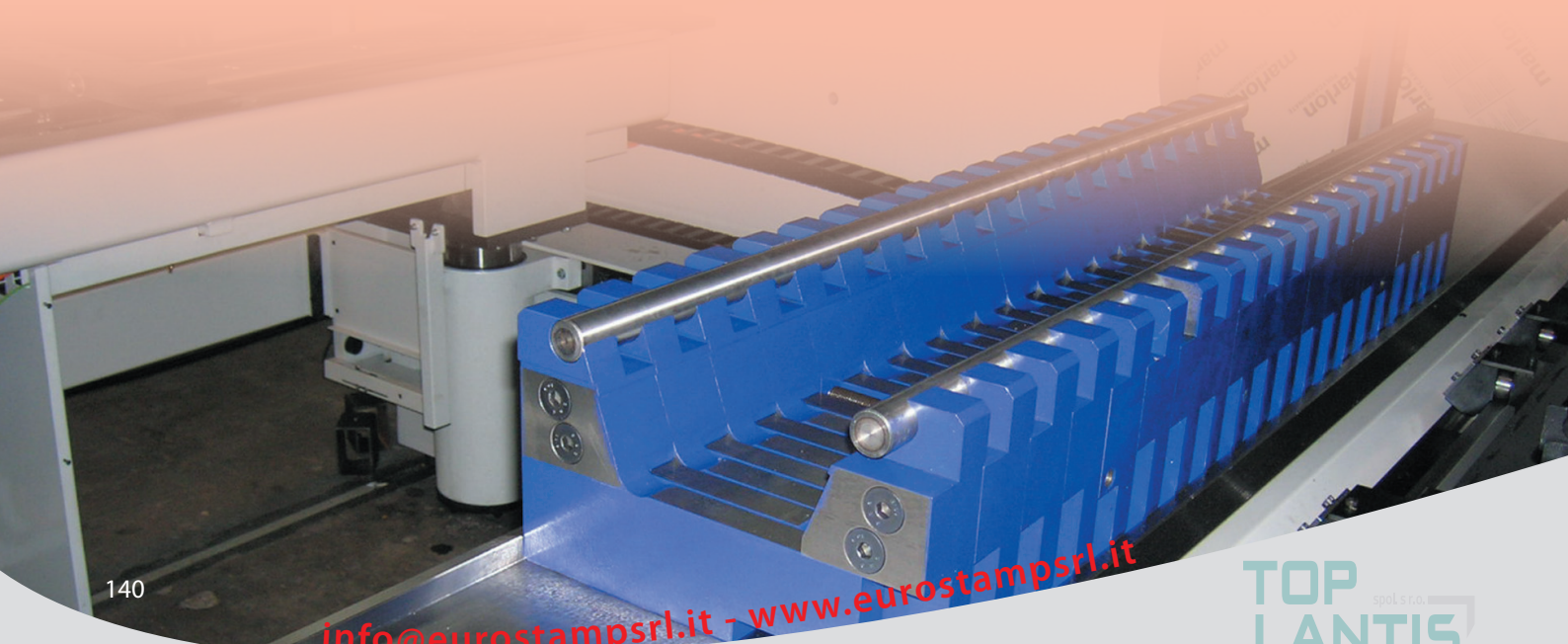
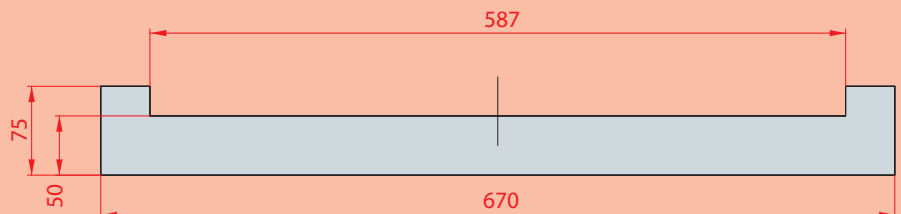

NASTAVITELNÉ MATRICE / ADJUSTABLE DIES

- C45 zušlechťená/quenched
- 42CrMo4
- C45

Pro tuto nastavitelnou matici je potřeba speciální držák matic
 This adjustable die needs a special die holder

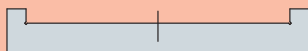

kód 9015 (str. 140)

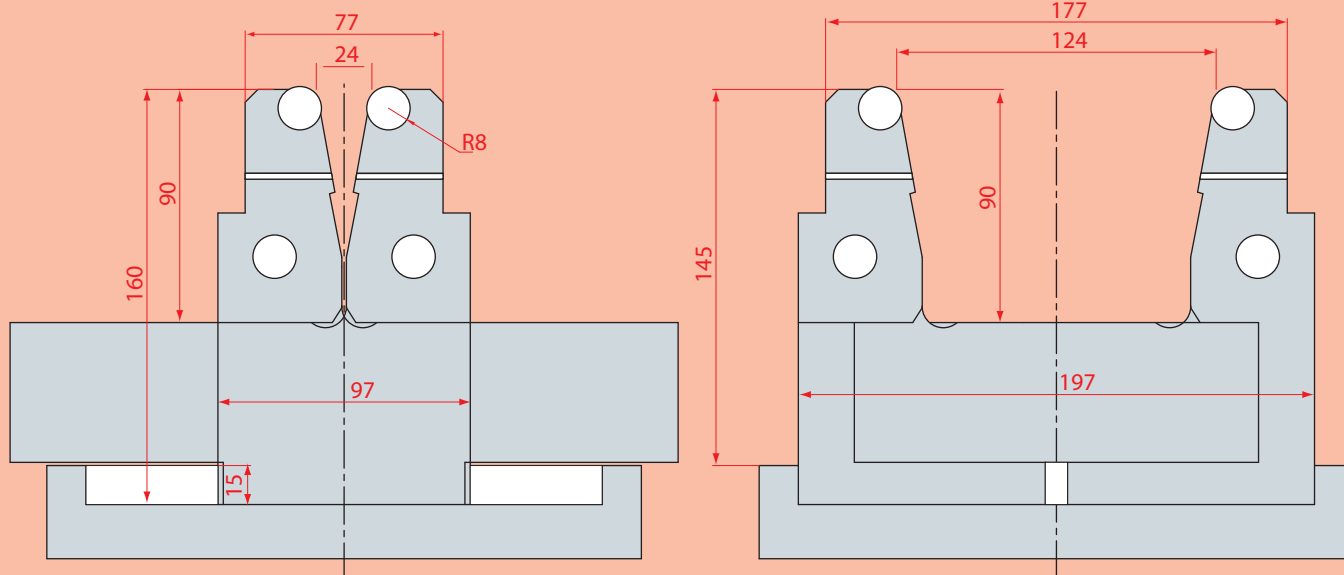

3190

Maximální úhel ohybu $\alpha = 60^\circ$ V= od 24 do 124 L=1000 Max=125 T/m při 90°
 Maximum bending angle $\alpha = 60^\circ$ V= from 24 to 124 L=1000 Max=125 T/m at 90°

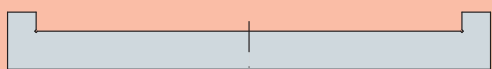

kód 9016 (str. 140)

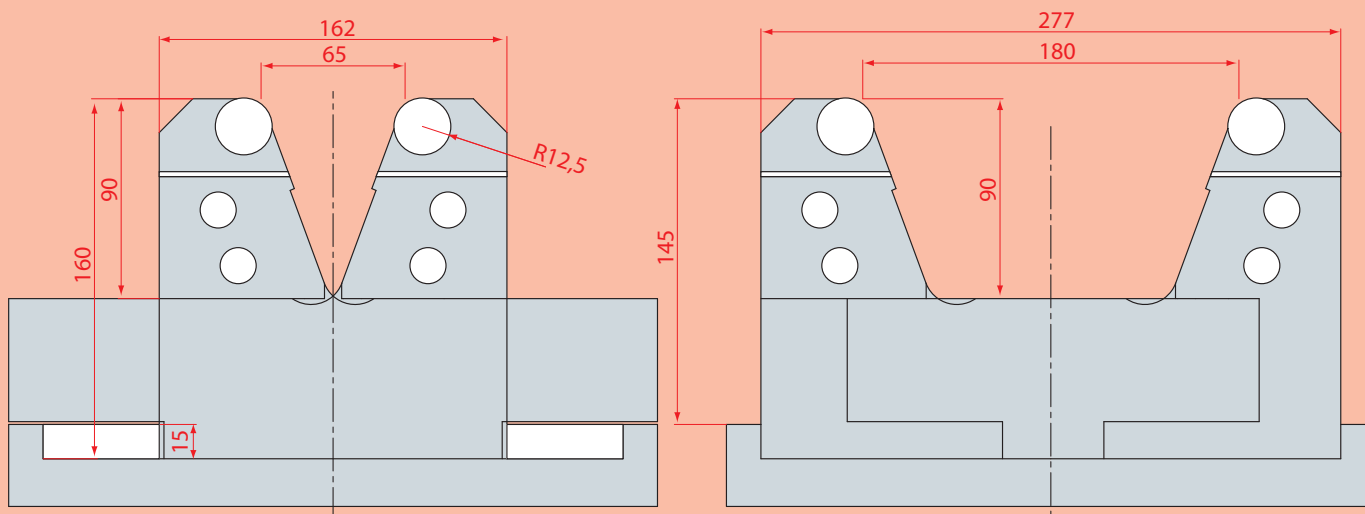

3191

Maximální úhel ohybu $\alpha = 60^\circ$ V= od 60 do 180 L=1000 Max=200 T/m při 90°
 Maximum bending angle $\alpha = 60^\circ$ V= from 60 to 180 L=1000 Max=200 T/m at 90°

NASTAVITELNÉ MATRICE / ADJUSTABLE DIES

- C45 zušlechťená/quenched
- 42CrMo4
- C45

Pro tuto nastavitelnou matici je potřeba speciální držák matic
 This adjustable die needs a special die holder



kód 9014 (str. 140)

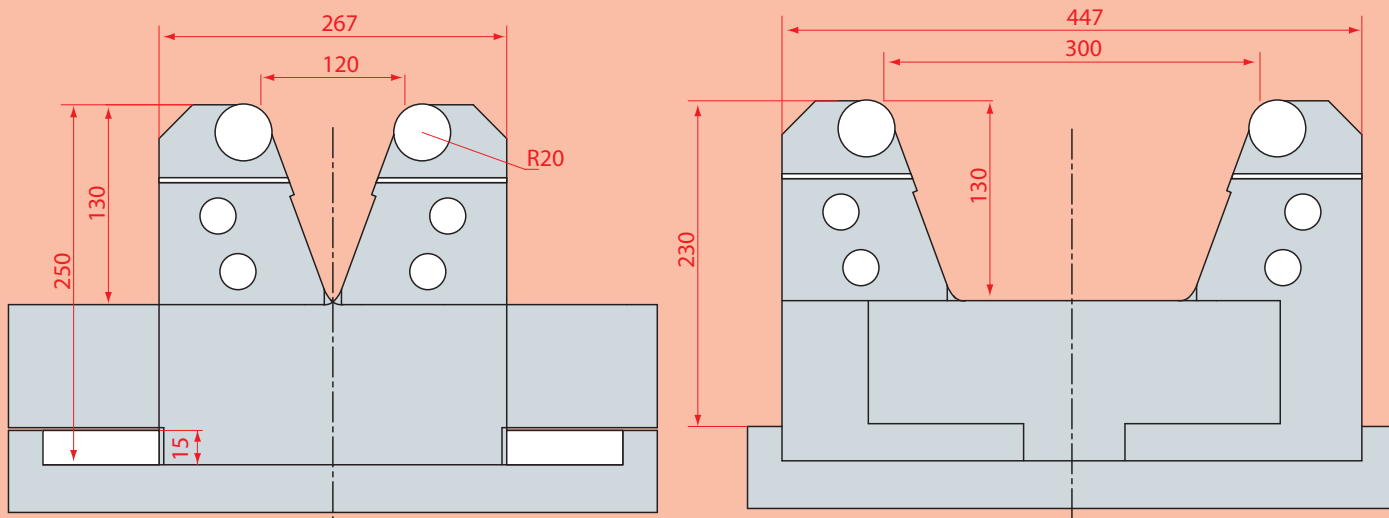

3192

Maximální úhel ohybu $\alpha = 60^\circ$ V= od 120 do 300 L=600 Max=400 T/m při 90°
 Maximum bending angle $\alpha = 60^\circ$ V= from 120 to 300 L=600 Max=400 T/m at 90°

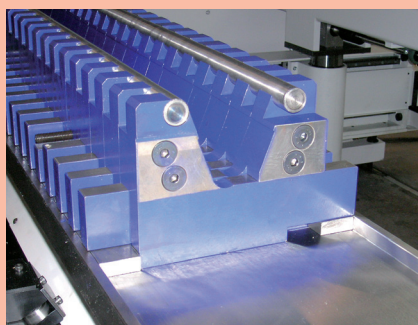
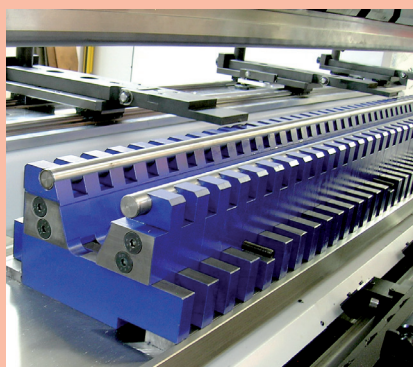

NASTAVITELNÉ MATRICE / ADJUSTABLE DIES

■ C45 zušlechťená/quenched
 ■ 42CrMo4
 ■ C45

Pro tuto nastavitelnou matici je potřeba speciální držák matic
 This adjustable die needs a special die holder

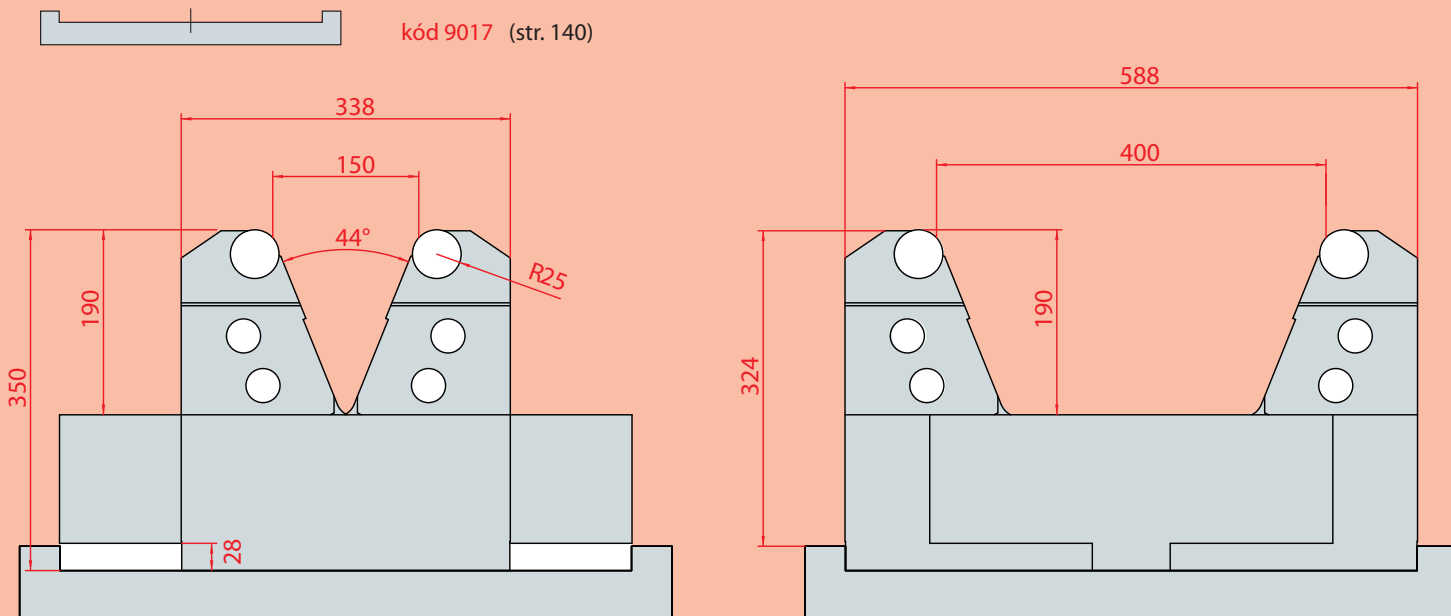

3243

Maximální úhel ohybu $\alpha = 60^\circ$ V= od 150 do 400 L=600 Max=400 T/m při 90°
 Maximum bending angle $\alpha = 60^\circ$ V= from 150 to 400 L=600 Max=400 T/m at 90°

