

# RAZNÍKY / PUNCHES

STANDARDNÍ DÉLKA /  
STANDARD LENGTHS

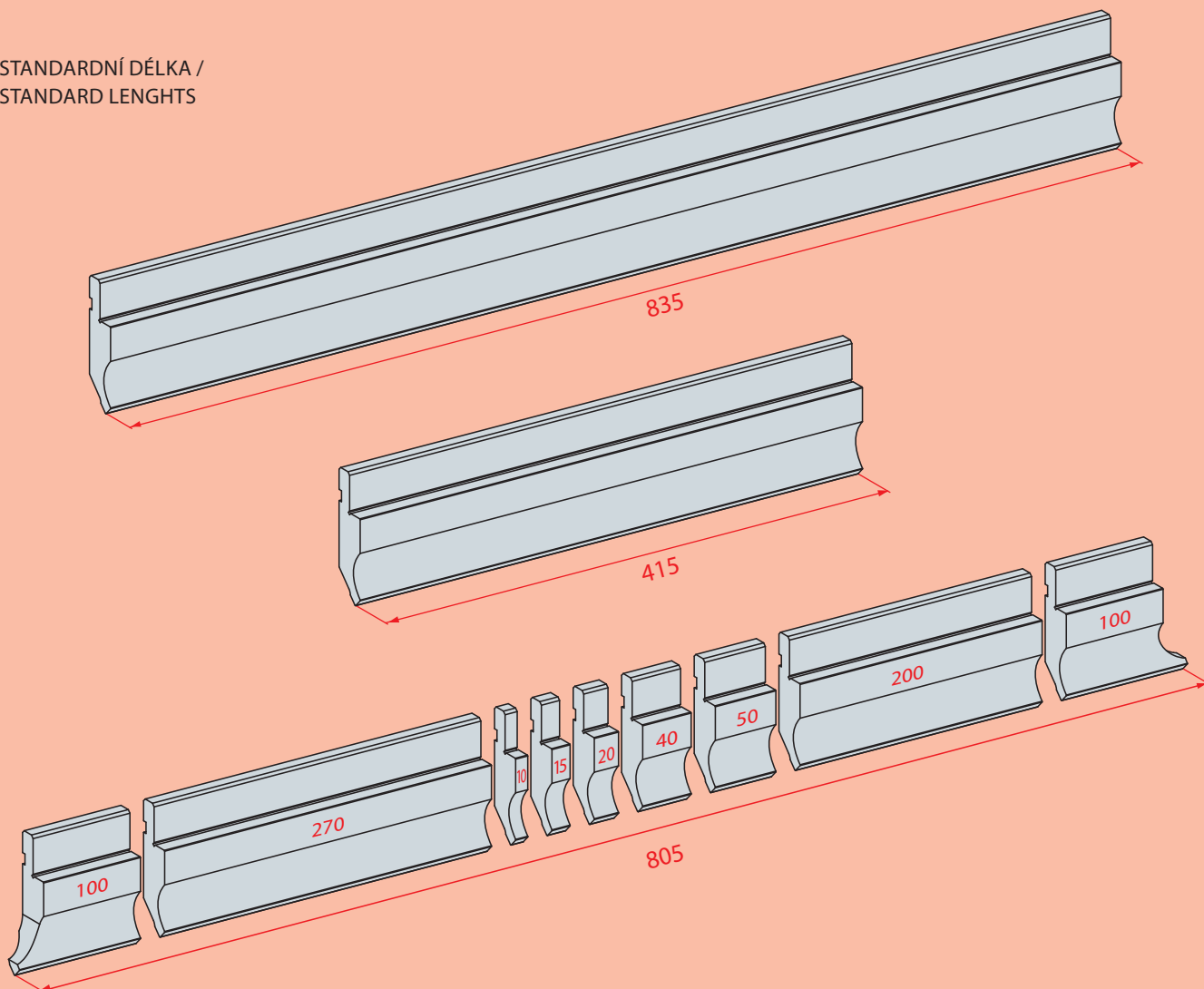

STANDARDNÍ DĚLENÍ /  
STANDARD SECTIONING

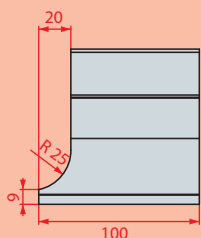

POHYBLIVÉ ROHY  
MILLING HORN

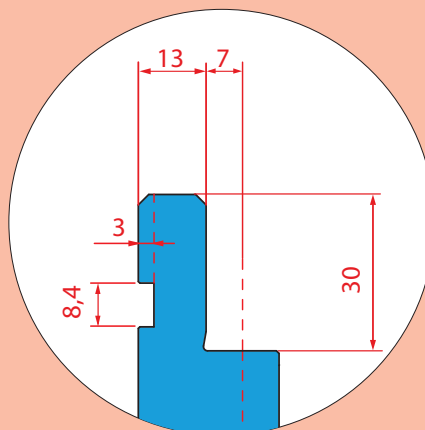

# POHYBLIVÉ ROHY / MOVING HORNS

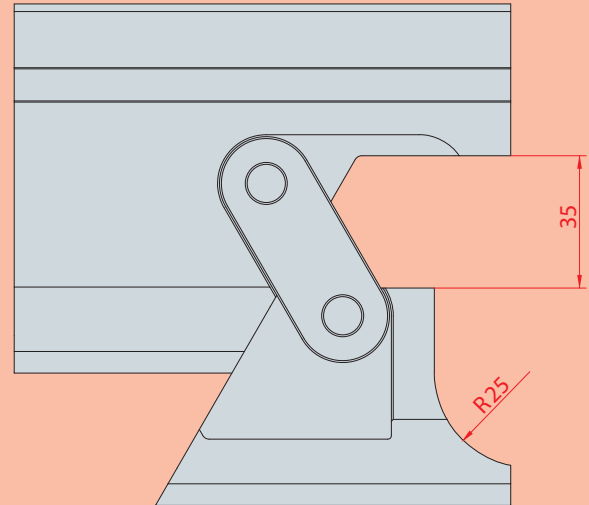
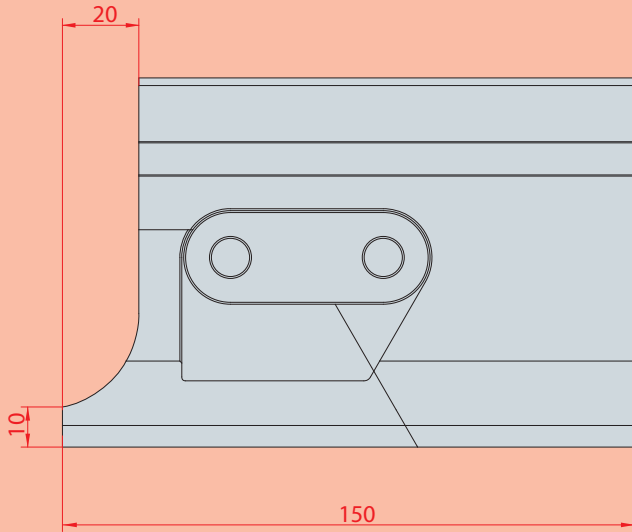

Razník	Pohyblivé rohy
Punch	Moving Horns
1010	1010S
1011	1011S
1064	1064S
1065	1065S
1047	1047S

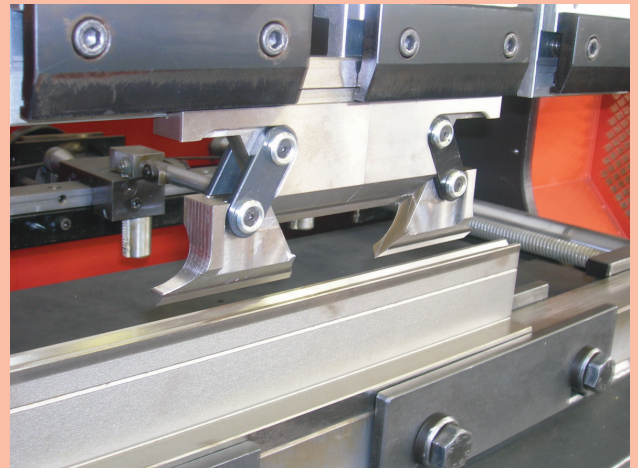
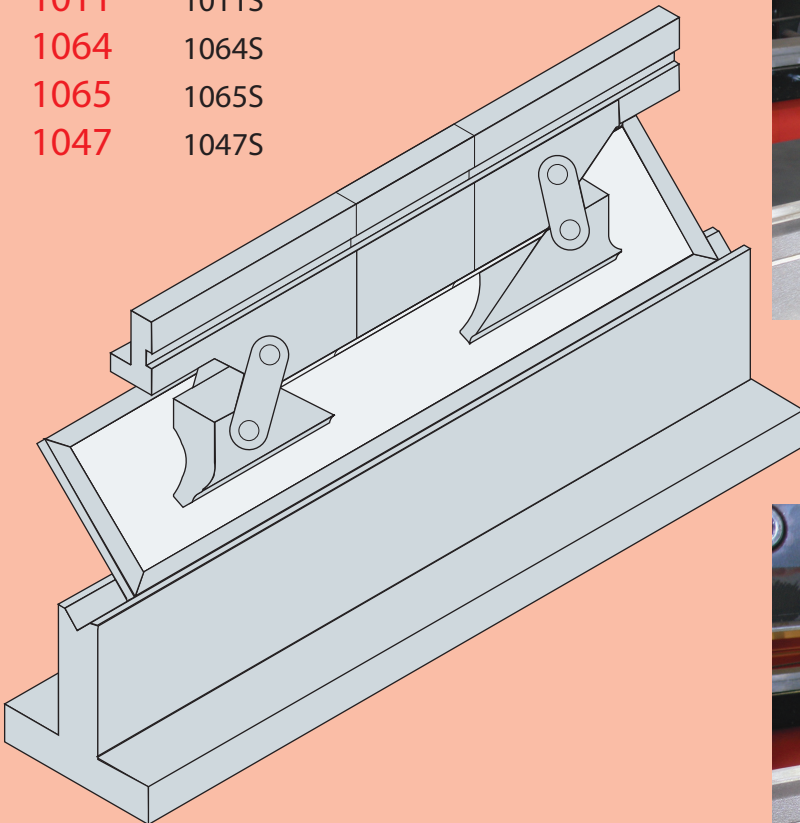

RAZNÍK - 90° / PUNCHES - 90°

■ C45 zušlechtěná/quenched  
■ 42CrMo4  
■ C45

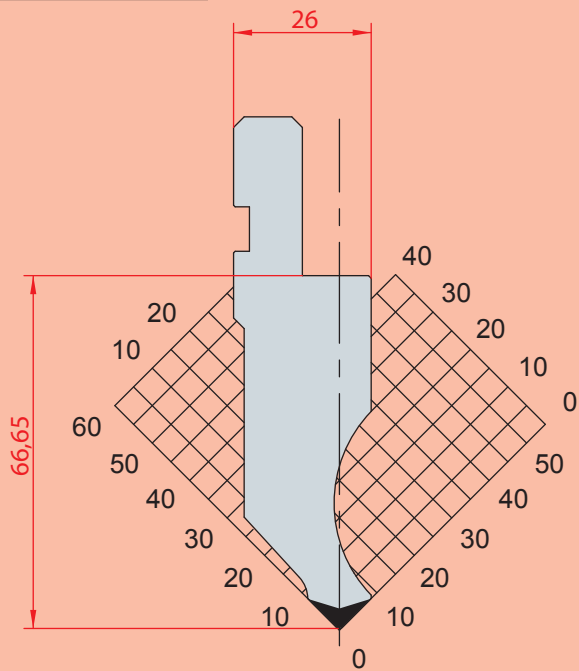

**1010**

$\alpha=90^\circ$  R=0.8 H=66.65 Max T/m=100

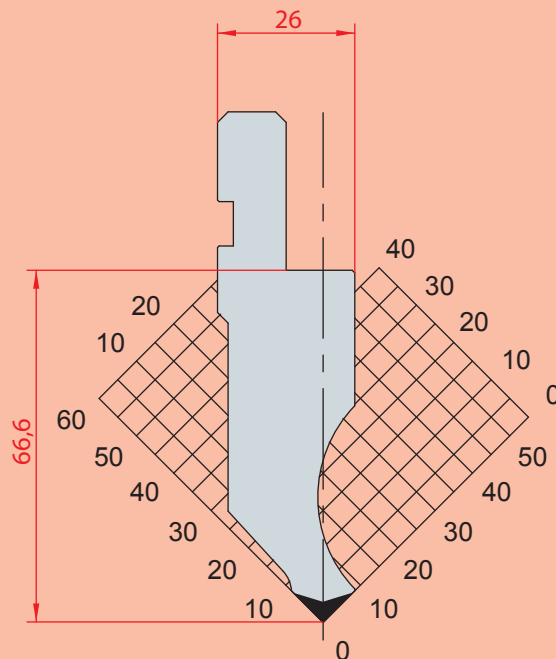

**1064**

$\alpha=90^\circ$  R=0.25 H=66.60 Max T/m=100

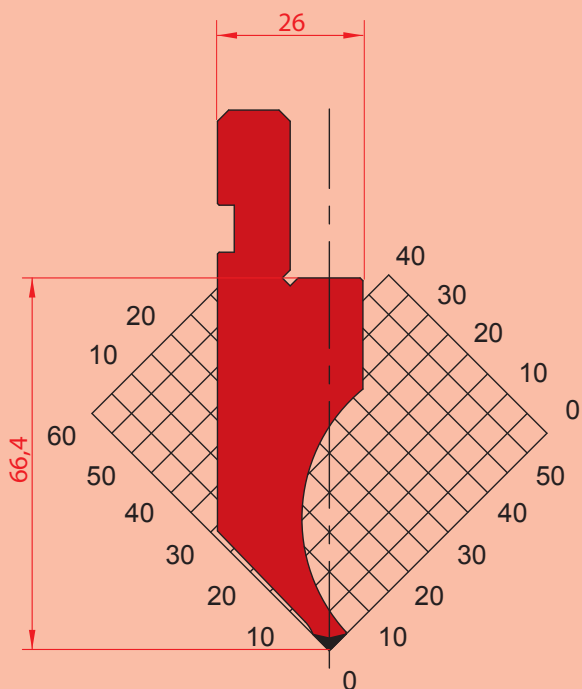

**1048**

$\alpha=90^\circ$  R=0.6 H=66.40 Max T/m=35

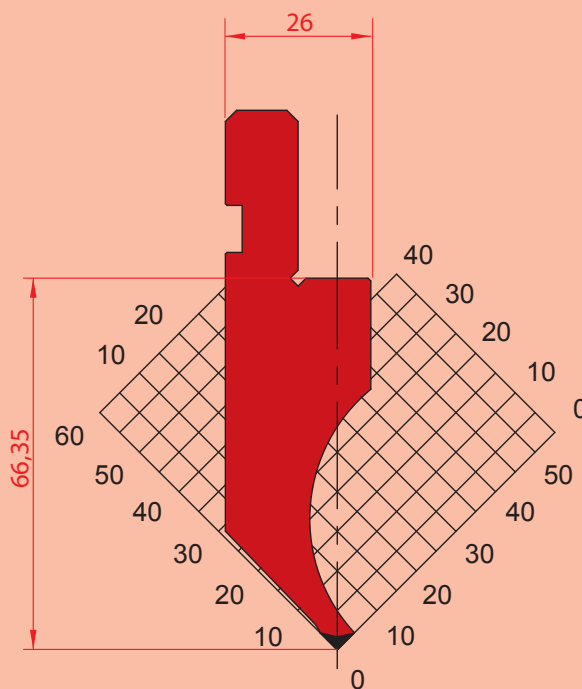

**1263**

$\alpha=90^\circ$  R=0.25 H=66.35 Max T/m=35

RAZNÍK - 90° / PUNCHES - 90°

- C45 zušlechtěná/quenched
- 42CrMo4
- C45

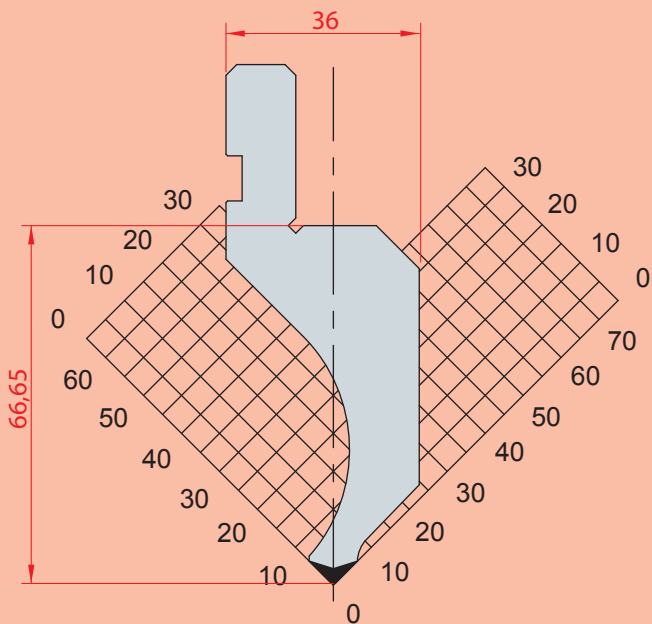

**1080**

$\alpha=90^\circ$  R=0.8 H=66.65 Max T/m=60

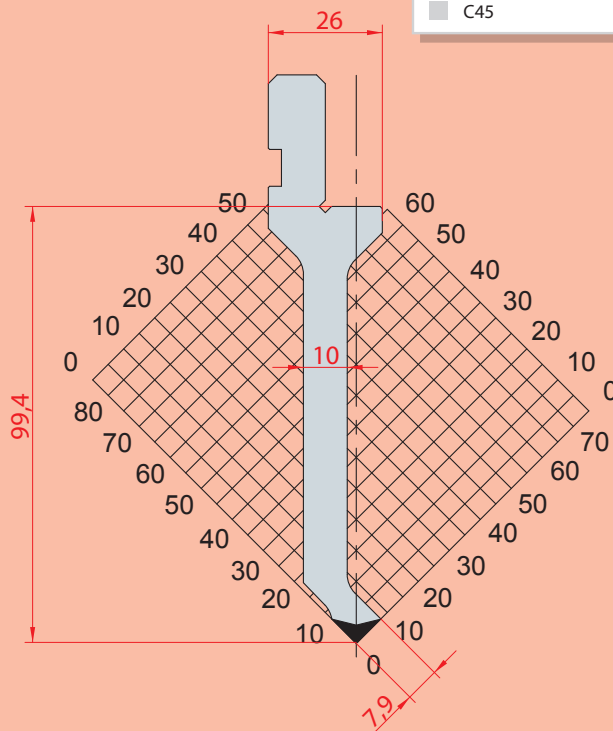

**1028**

$\alpha=90^\circ$  R=0.6 H=99.40 Max T/m=50

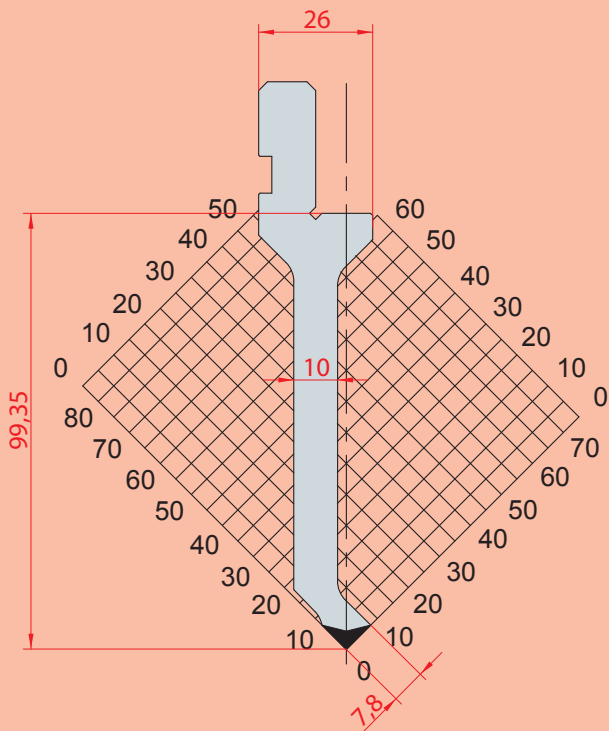

**1261**

$\alpha=90^\circ$  R=0.25 H=99.35 Max T/m=50

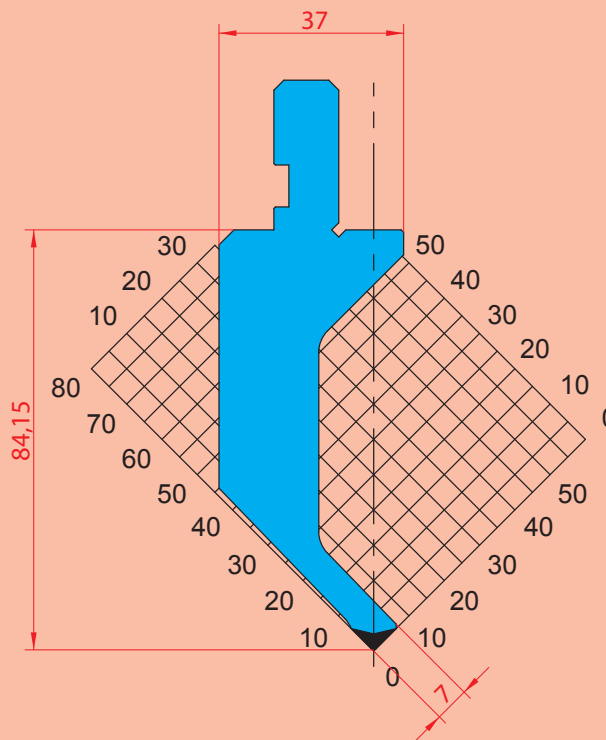

**1019**

$\alpha=90^\circ$  R=0.6 H=84.15 Max T/m=20

RAZNÍK - 90° / PUNCHES - 90°

■ C45 zušlechtěná/quenched  
■ 42CrMo4  
■ C45

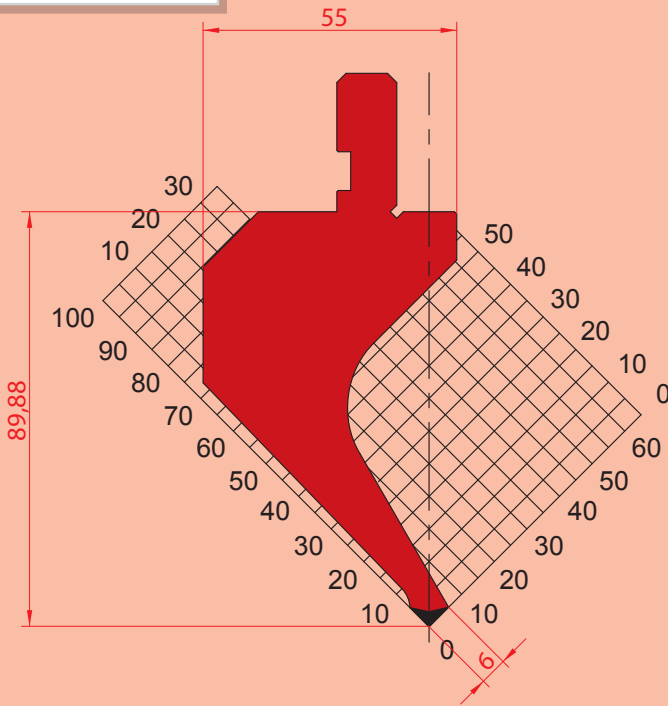

1176

$\alpha=90^\circ$  R=0.25 H=89.88 Max T/m=50

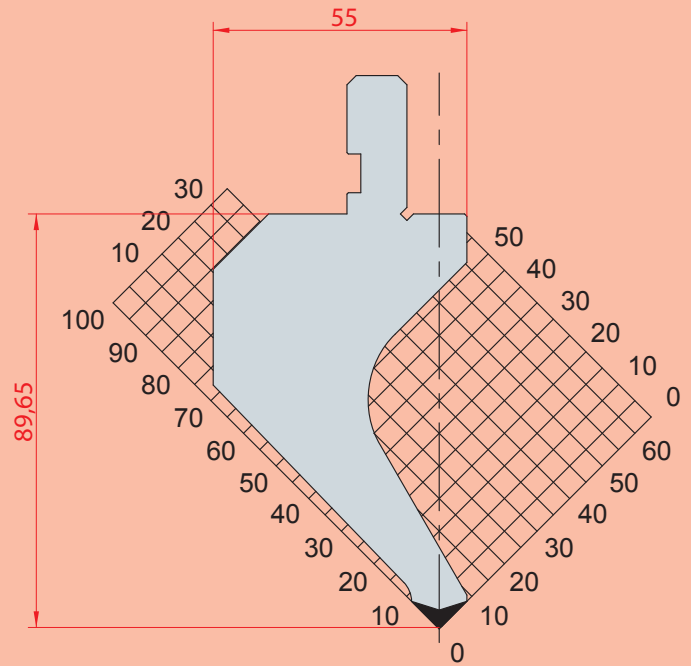

1013

$\alpha=90^\circ$  R=0.8 H=89.65 Max T/m=60

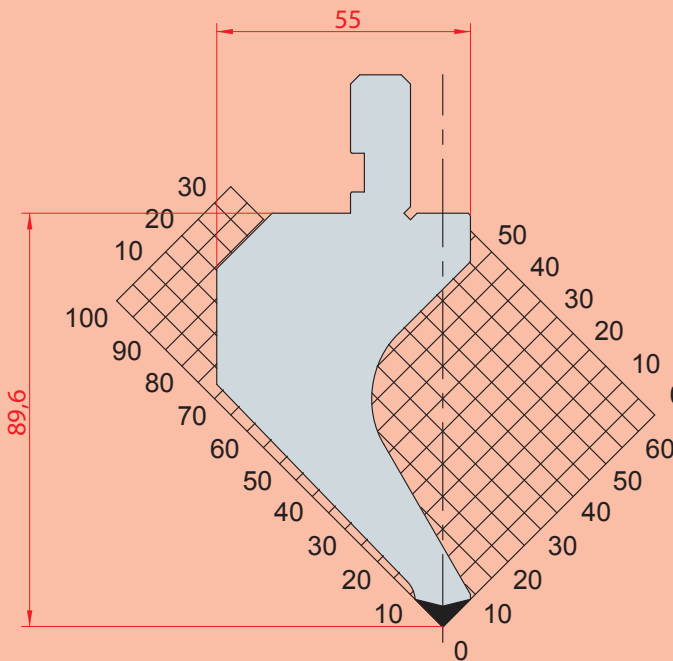

1265

$\alpha=90^\circ$  R=0.25 H=89.60 Max T/m=60

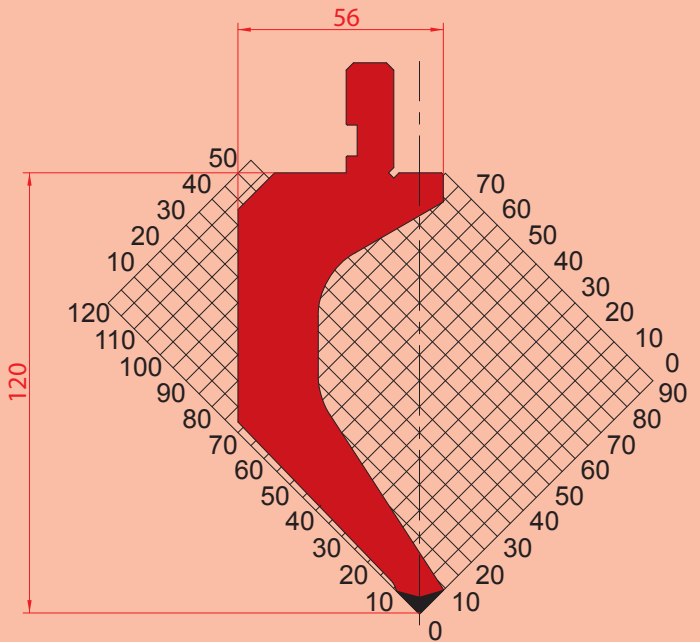

1060

$\alpha=90^\circ$  R=0.8 H=120.00 Max T/m=50

RAZNÍK - 90° / PUNCHES 90°

<span style="color: red;">■</span>	C45 zušlechtěná/quenched
<span style="color: lightblue;">■</span>	42CrMo4
<span style="color: gray;">■</span>	C45

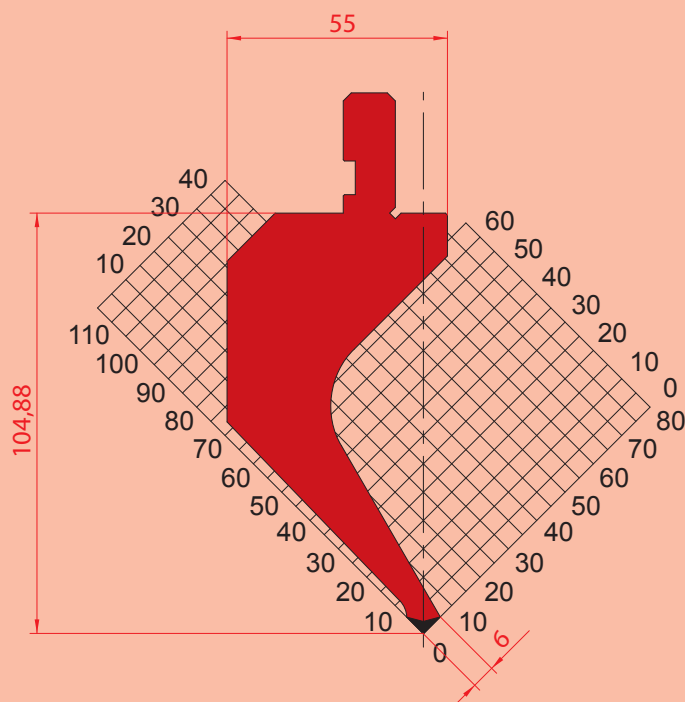

1174

$\alpha=90^\circ$  R=0.25 H=104.88 Max T/m=50

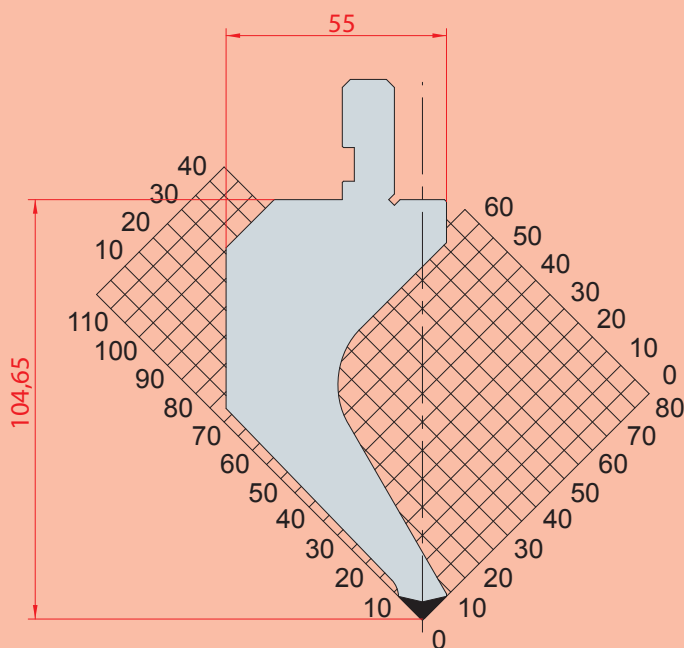

1016

$\alpha=90^\circ$  R=0.8 H=104.65 Max T/m=50

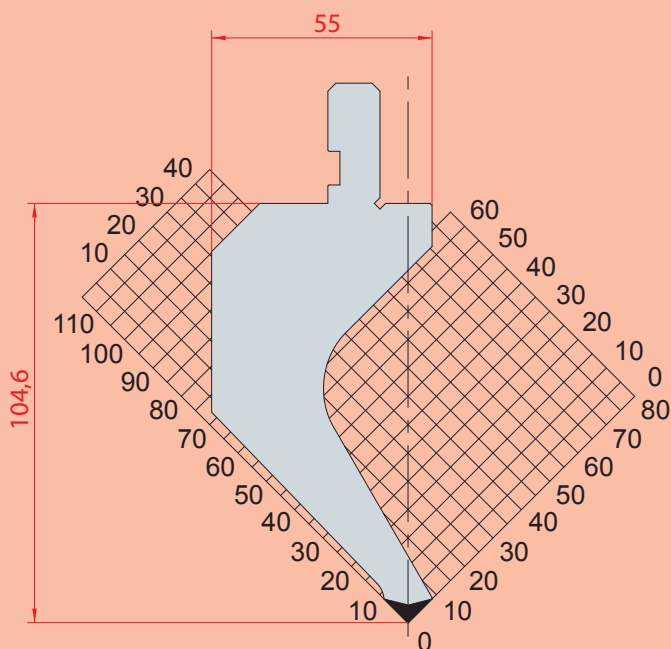

1267

$\alpha=90^\circ$  R=0.25 H=104.60 Max T/m=50

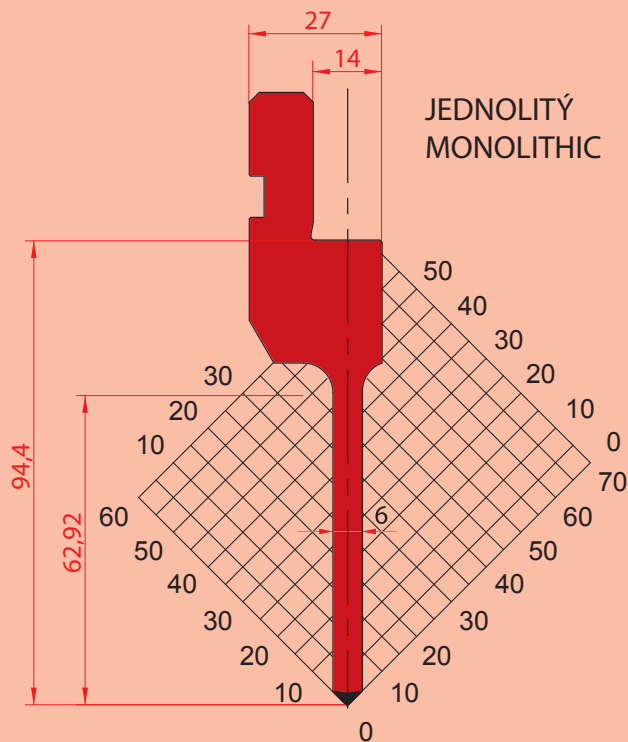

1083

$\alpha=90^\circ$  R=0.6 H=94.40 Max T/m=50

RAZNÍK - 90° / PUNCHES - 90°

- C45 zušlechťená/quenched
- 42CrMo4
- C45

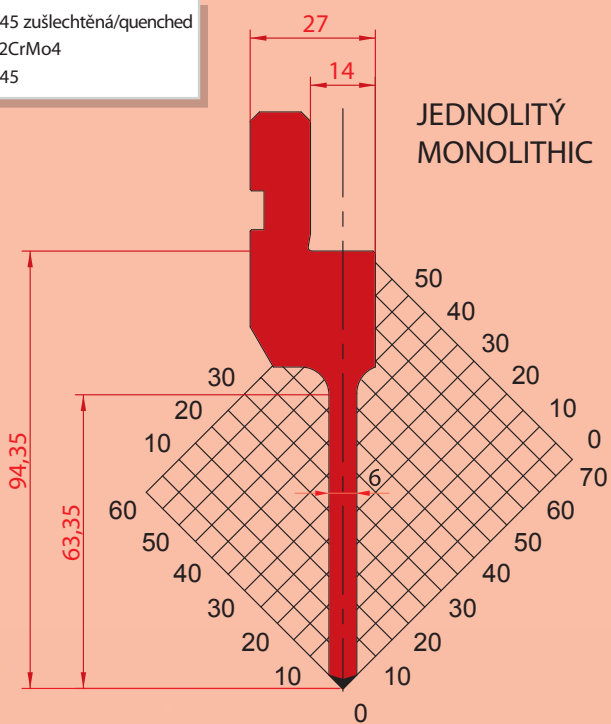

1269

$\alpha=90^\circ$  R=0.25 H=94.35 Max T/m=50

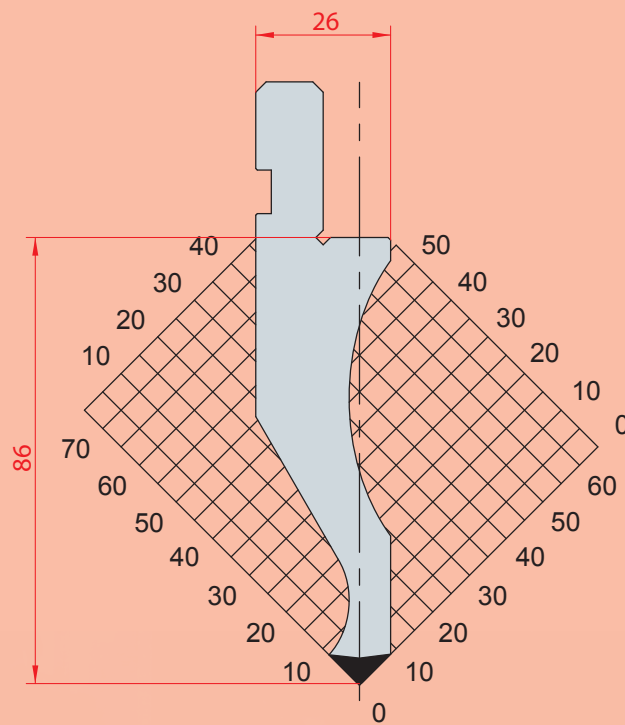

1021

$\alpha=90^\circ$  R=0.8 H=86.00 Max T/m=100

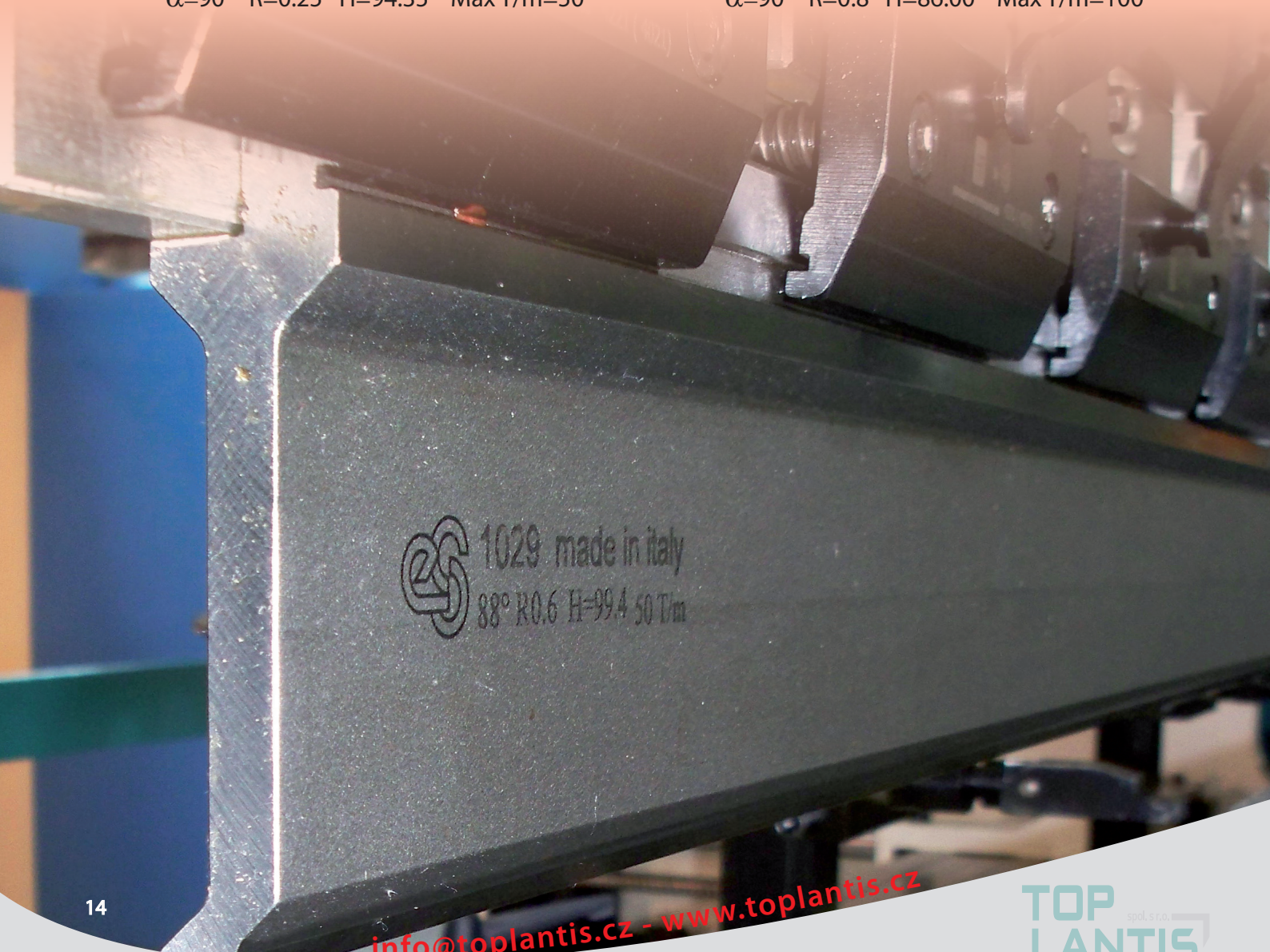

 1029 made in italy  
88° R0.6 H=99.4 50 T/m

RAZNÍK - 88° / PUNCHES 88°

<span style="color: red;">■</span>	C45 zušlechtěná/quenched
<span style="color: blue;">■</span>	42CrMo4
<span style="color: gray;">■</span>	C45

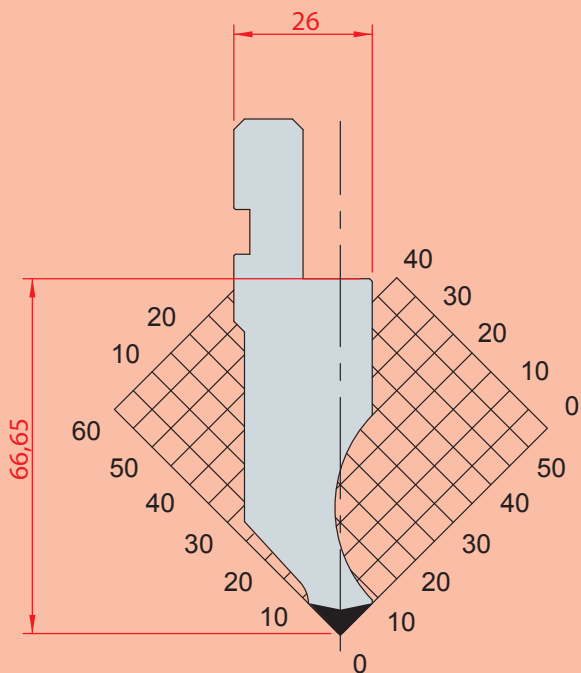

1011

$\alpha=88^\circ$  R=0.8 H=66.65 Max T/m=100

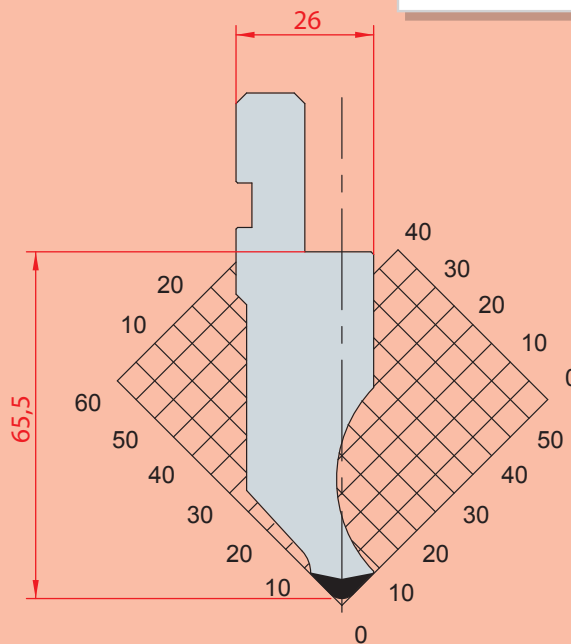

1012

$\alpha=88^\circ$  R=3 H=65.50 Max T/m=100

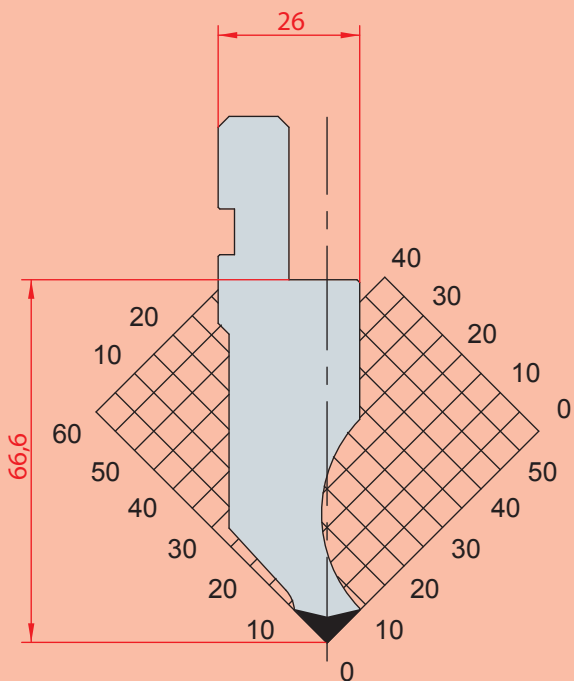

1065

$\alpha=88^\circ$  R=0.25 H=66.60 Max T/m=100

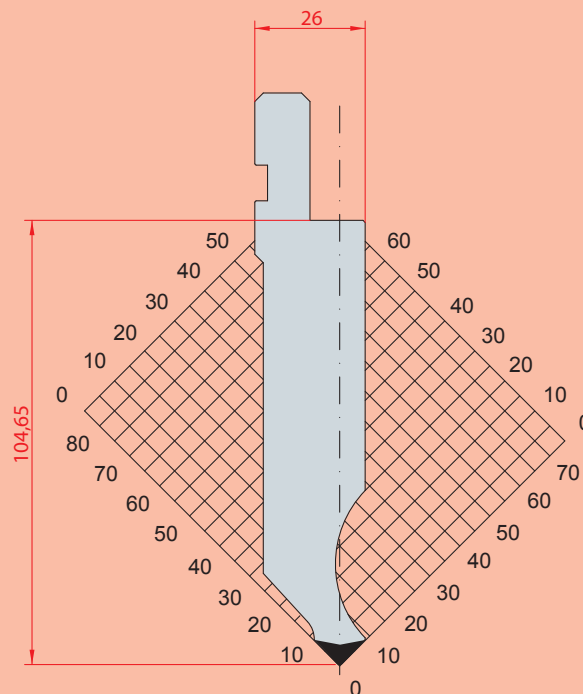

1063

$\alpha=88^\circ$  R=0.8 H=104.65 Max T/m=100



# RAZNÍK - 88° / PUNCHES 88°

■ C45 zušlechťená/quenched  
■ 42CrMo4  
■ C45

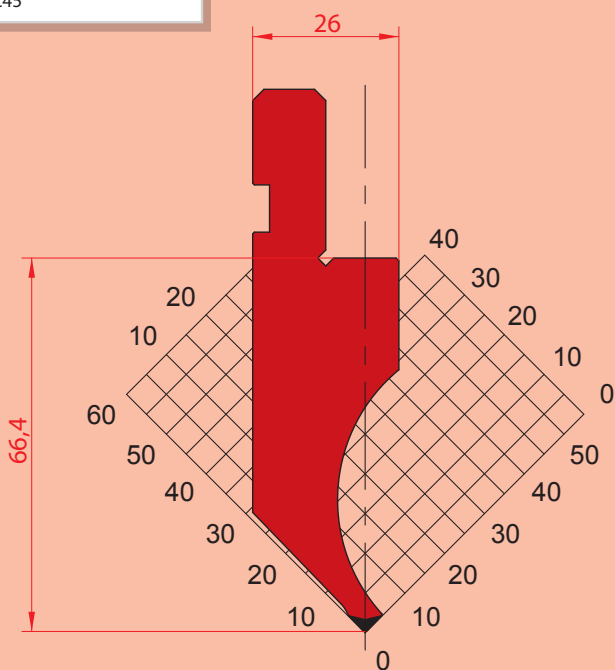

**1049**

$\alpha=88^\circ$  R=0.6 H=66.40 Max T/m=35

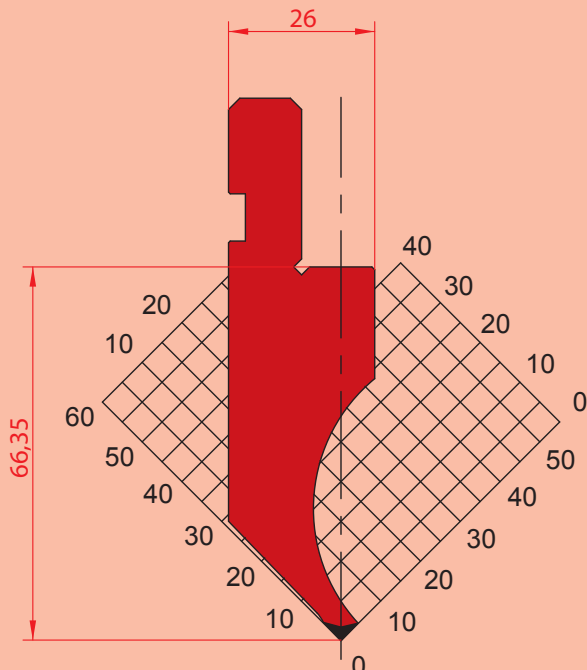

**1264**

$\alpha=88^\circ$  R=0.25 H=66.35 Max T/m=35

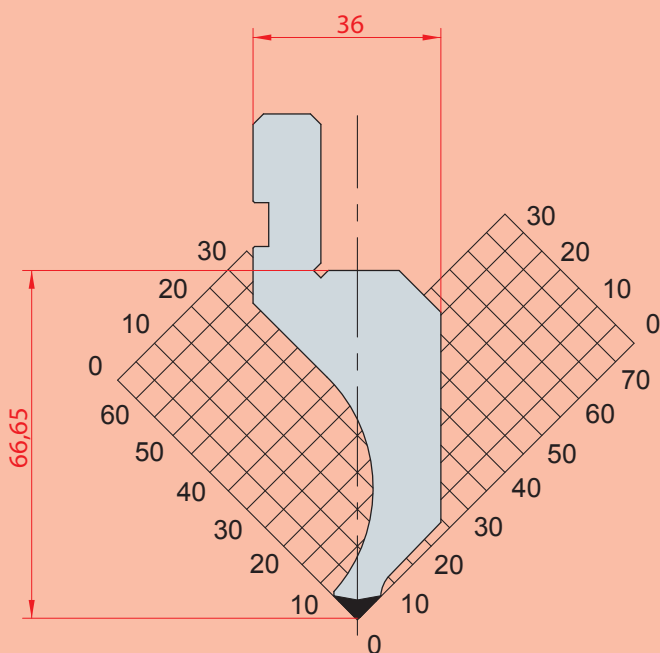

**1081**

$\alpha=88^\circ$  R=0.8 H=66.65 Max T/m=60

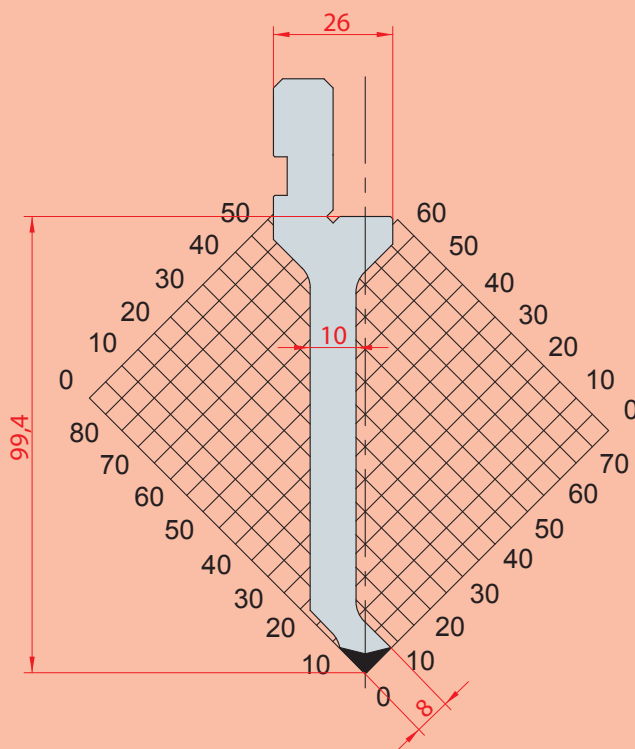

**1029**

$\alpha=88^\circ$  R=0.6 H=99.40 Max T/m=50

RAZNÍK - 88° / PUNCHES 88°

■	C45 zušlechtěná/quenched
■	42CrMo4
■	C45

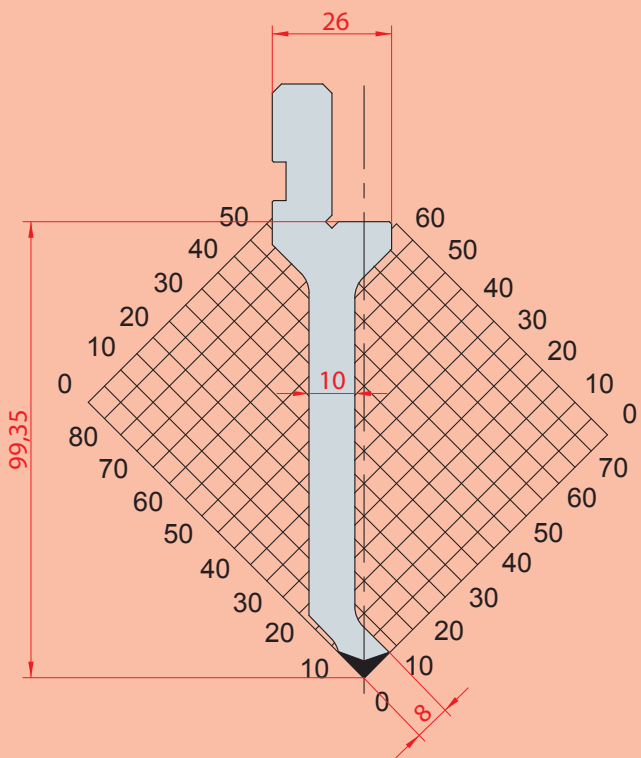

1262

$\alpha=88^\circ$  R=0.25 H=99.35 Max T/m=50

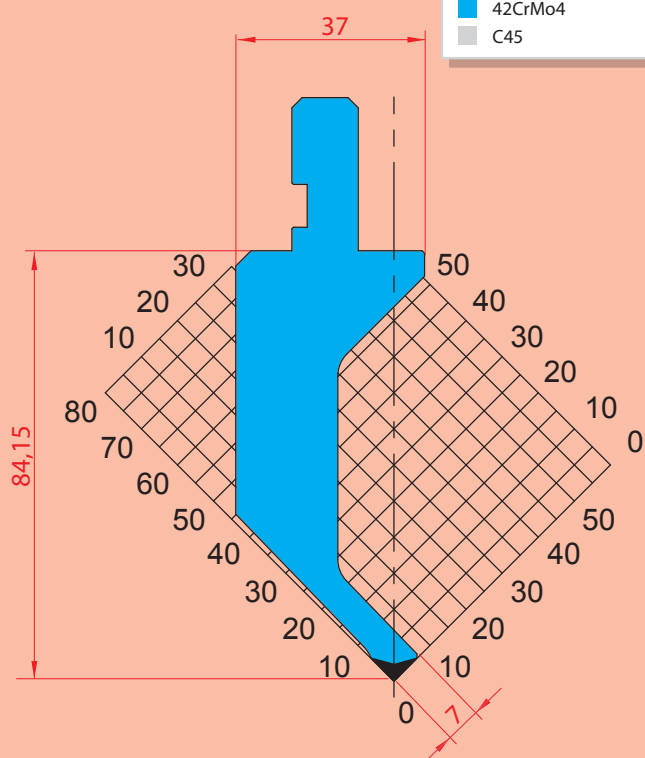

1020

$\alpha=88^\circ$  R=0.6 H=84.15 Max T/m=20

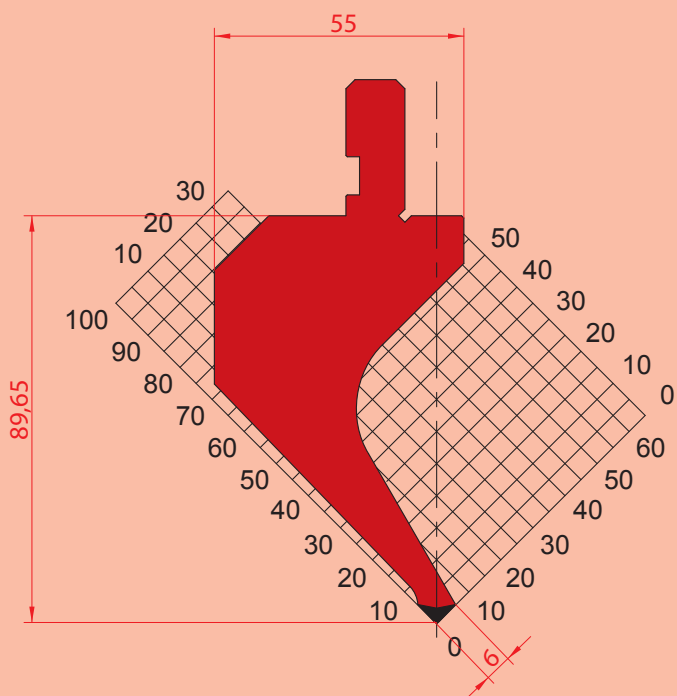

1175

$\alpha=88^\circ$  R=0.8 H=89.65 Max T/m=50

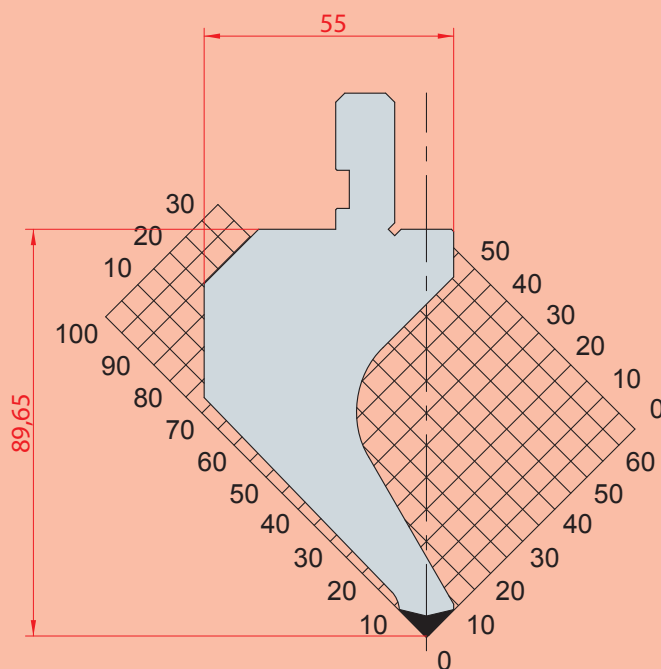

1014

$\alpha=88^\circ$  R=0.8 H=89.65 Max T/m=60

RAZNÍK - 88° / PUNCHES 88°

■ C45 zušlechtěná/quenched  
■ 42CrMo4  
■ C45

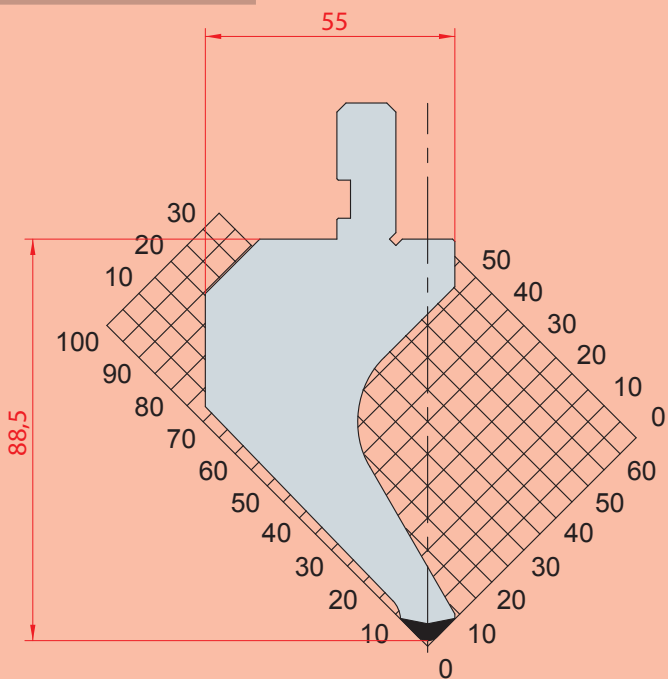

1015

$\alpha=88^\circ$  R=3 H=88.50 Max T/m=60

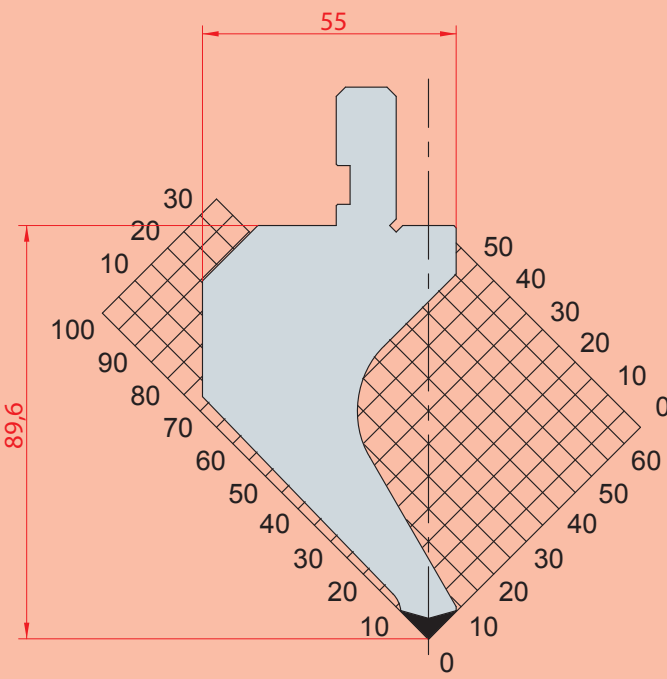

1266

$\alpha=88^\circ$  R=0.25 H=89.60 Max T/m=60

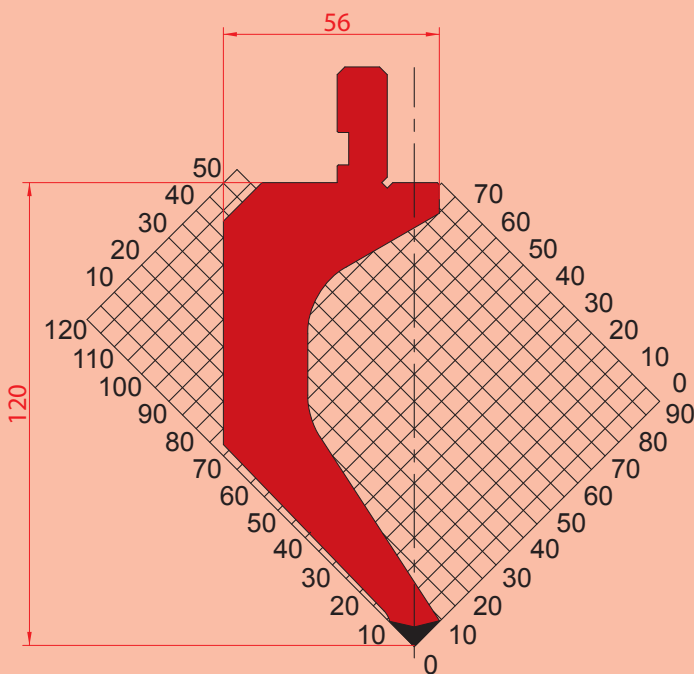

1061

$\alpha=88^\circ$  R=0.8 H=120.00 Max T/m=50

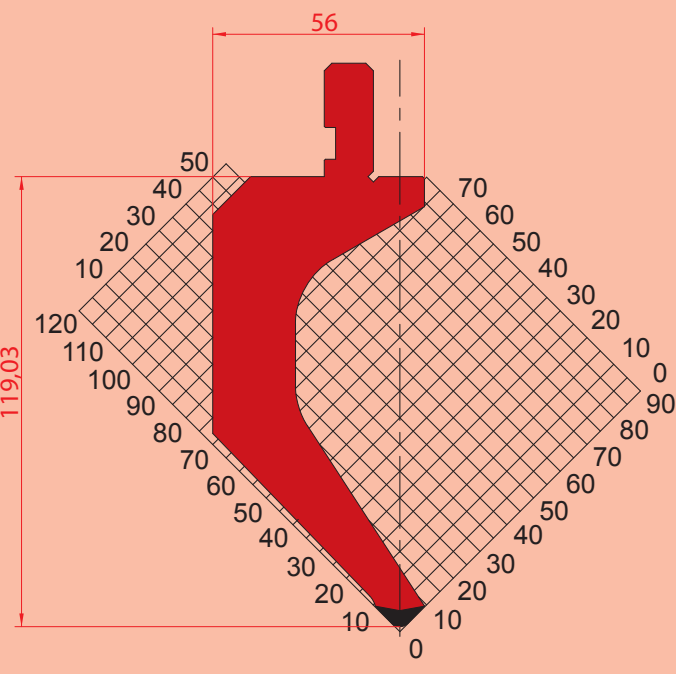

1062

$\alpha=88^\circ$  R=3 H=119.03 Max T/m=50

RAZNÍK - 88° / PUNCHES 88°

■ C45 zušlechťená/quenched  
■ 42CrMo4  
■ C45

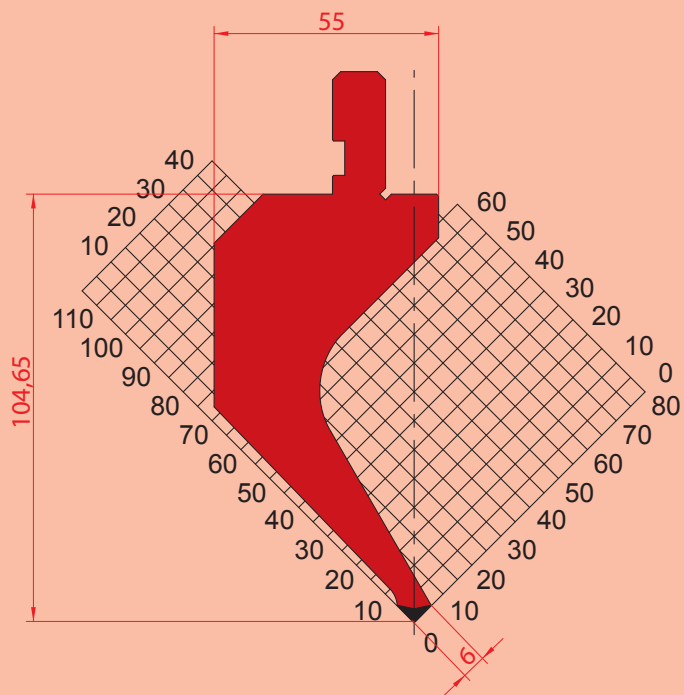

**1173**

$\alpha=88^\circ$  R=0.8 H=104.65 MaxT/m=50

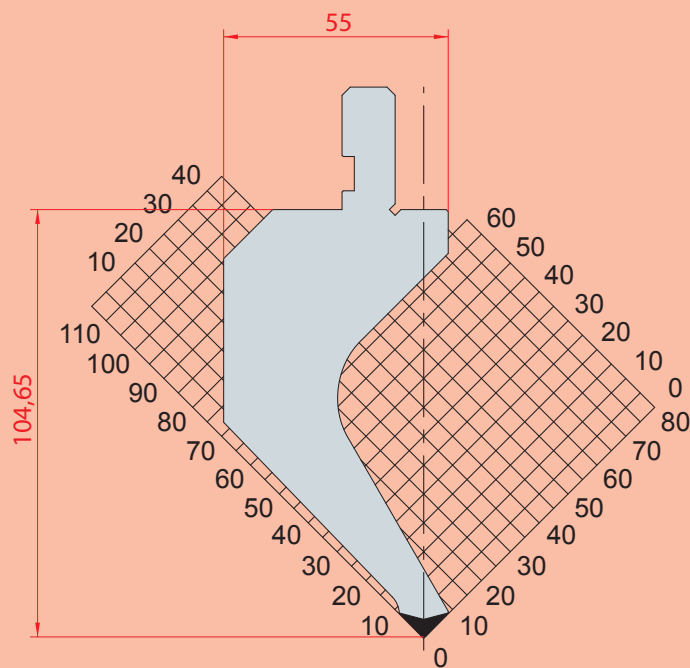

**1017**

$\alpha=88^\circ$  R=0.8 H=104.65 MaxT/m=50

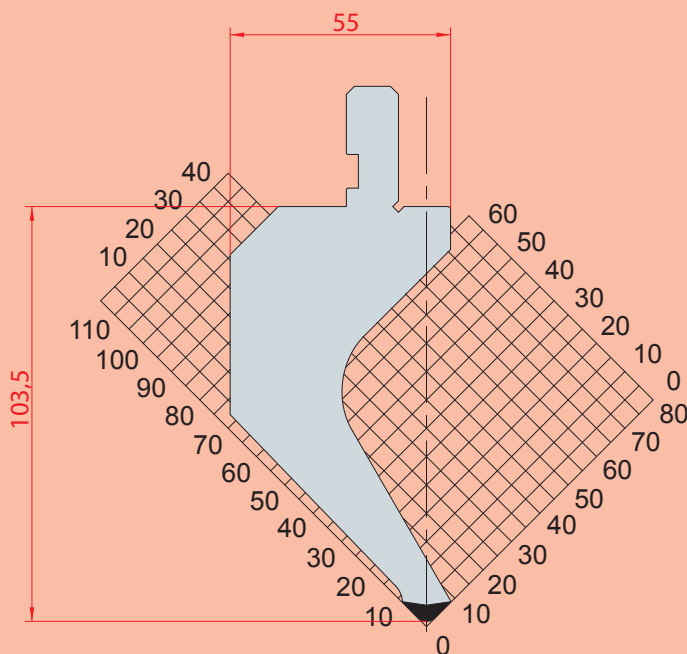

**1018**

$\alpha=88^\circ$  R=3 H=103.50 MaxT/m=50

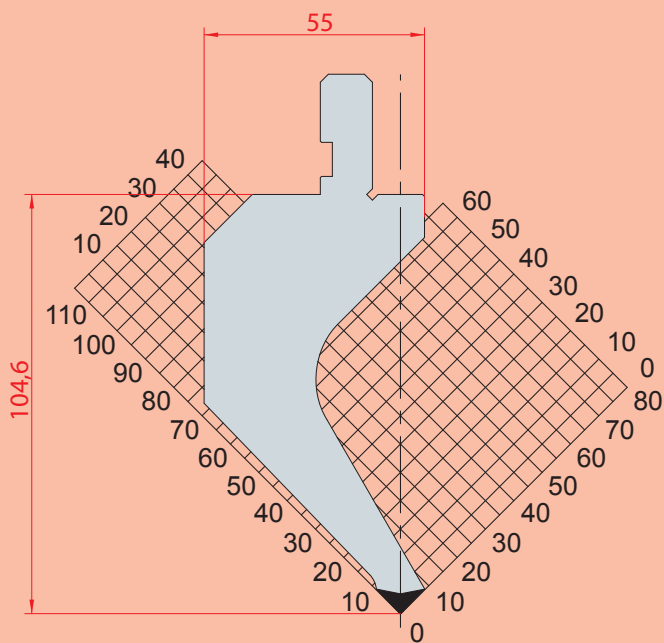

**1268**

$\alpha=88^\circ$  R=0.25 H=104.60 MaxT/m=50

RAZNÍK - 88° / PUNCHES 88°

- C45 zušlechtěná/quenched
- 42CrMo4
- C45

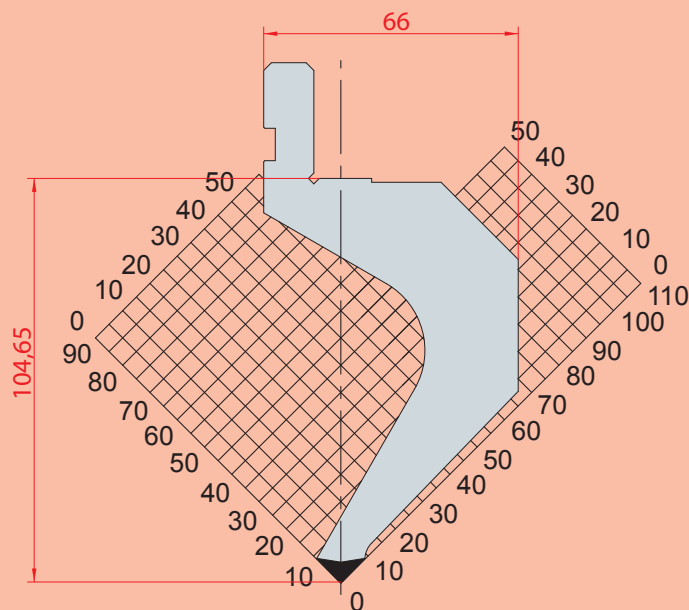

**1082**

$\alpha=88^\circ$  R=0.8 H=104.65 Max T/m=45

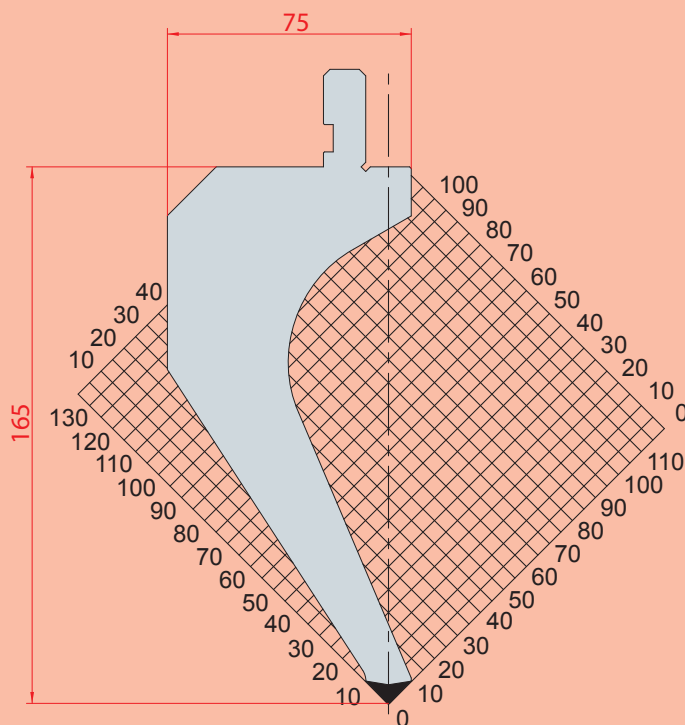

**1031**

$\alpha=88^\circ$  R=0.8 H=165.00 Max T/m=60

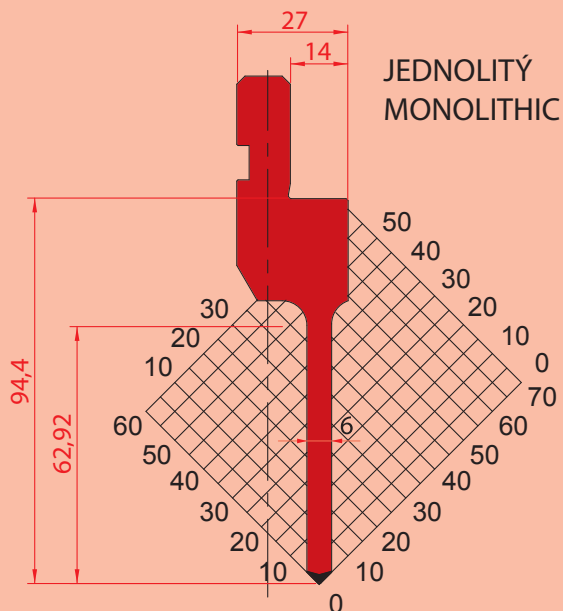

**1084**

$\alpha=88^\circ$  R=0.6 H=94.40 Max T/m=50

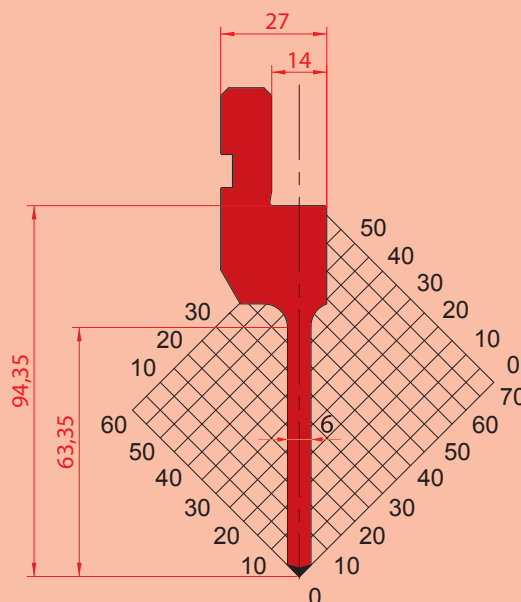

**1270**

$\alpha=88^\circ$  R=0.25 H=94.35 Max T/m=50

RAZNÍK - 88° / PUNCHES 88°

<span style="color: red;">■</span>	C45 zušlechtěná/quenched
<span style="color: lightblue;">■</span>	42CrMo4
<span style="color: gray;">■</span>	C45

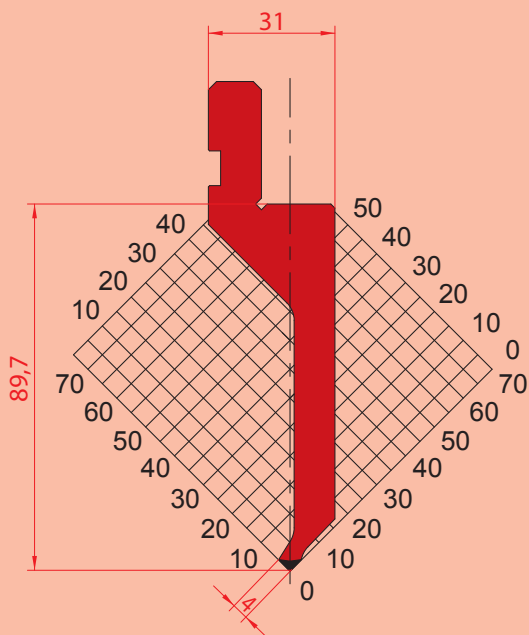

1290

$\alpha=88^\circ$  R=0.6 H=89.70 Max T/m=30

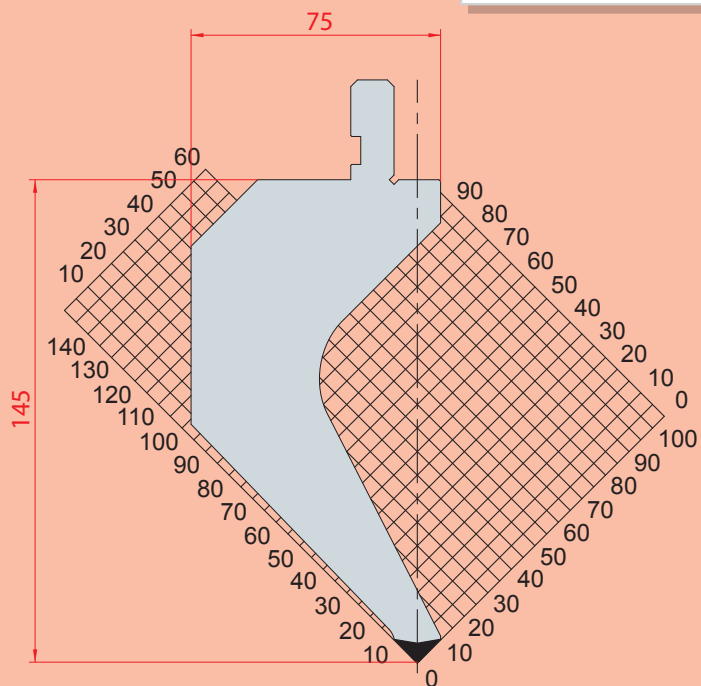

1030

$\alpha=88^\circ$  R=0.8 H=145.00 Max T/m=80

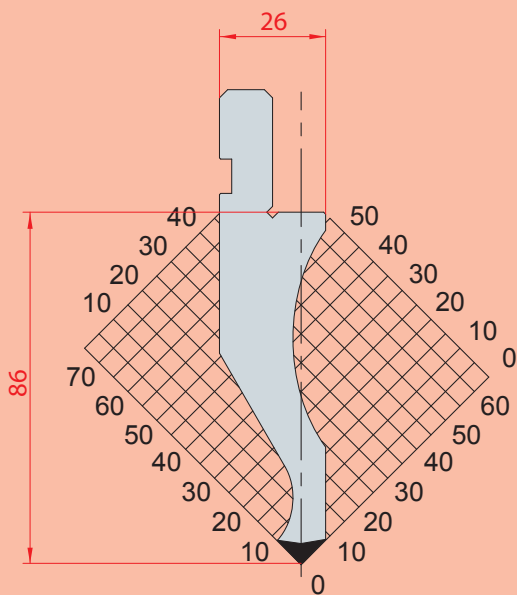

1022

$\alpha=88^\circ$  R=0.8 H=86.00 Max T/m=100

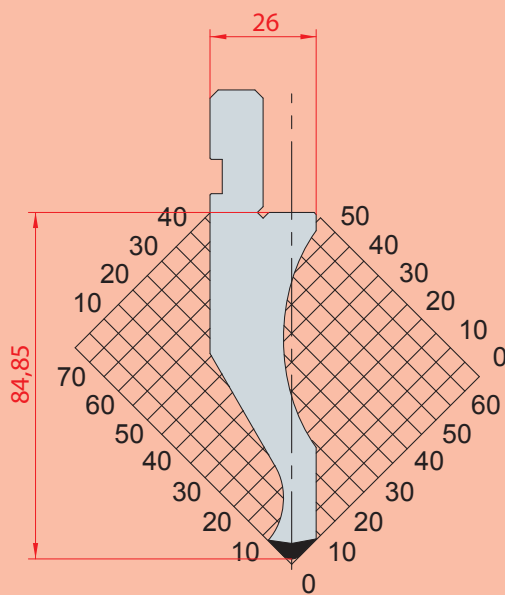

1023

$\alpha=88^\circ$  R=3 H=84.85 Max T/m=100

RAZNÍK - 88° / PUNCHES 88°

- C45 zušlechťená/quenched
- 42CrMo4
- C45

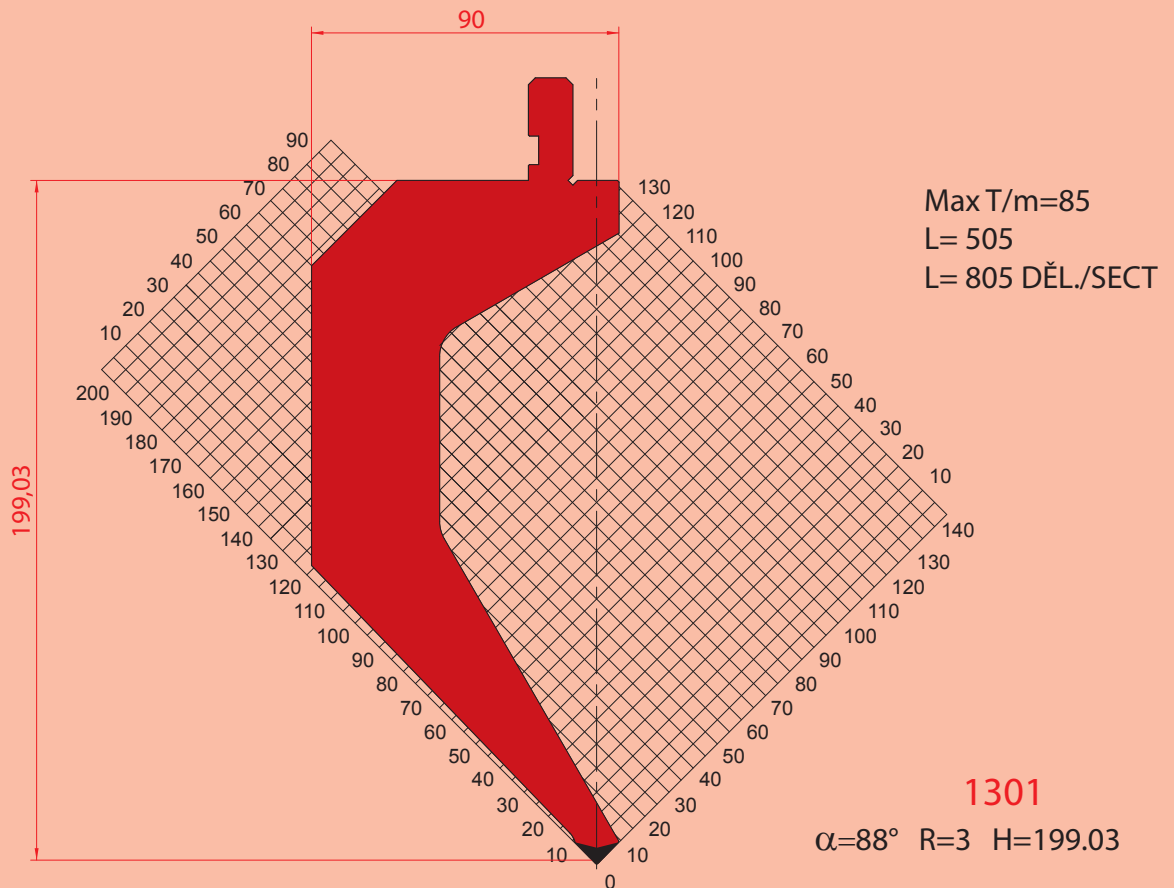
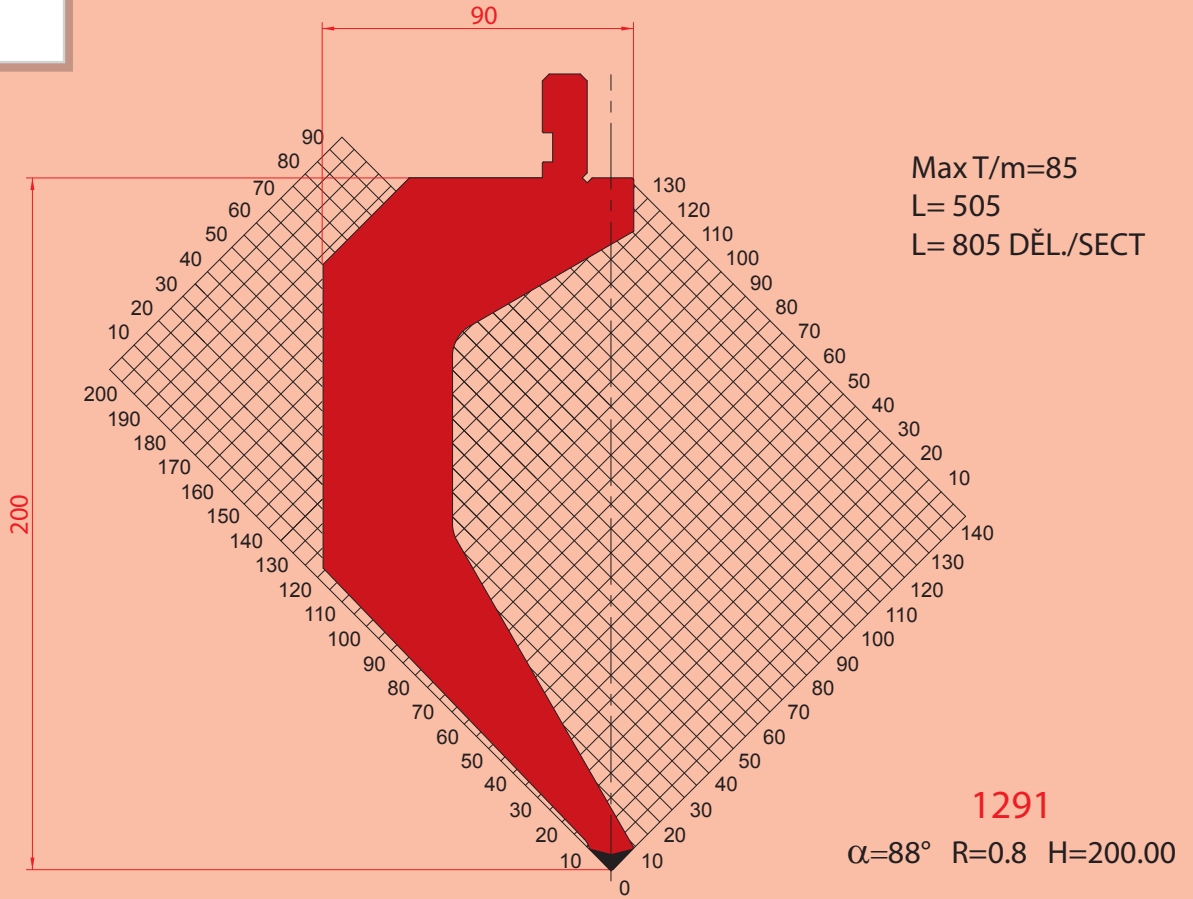

RAZNÍK - 85° / PUNCHES - 85°

■	C45 zušlechťená/quenched
■	42CrMo4
■	C45

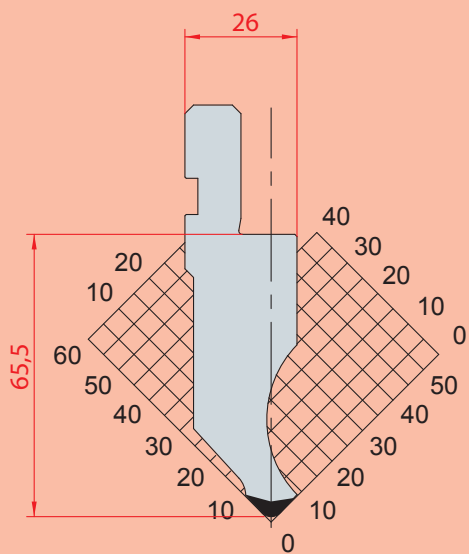

1177

$\alpha=85^\circ$  R=3 H=65.50 Max T/m=100

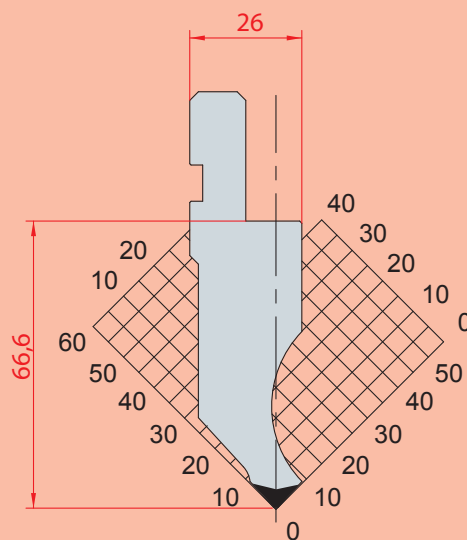

1260

$\alpha=85^\circ$  R=0.8 H=66.60 Max T/m=100

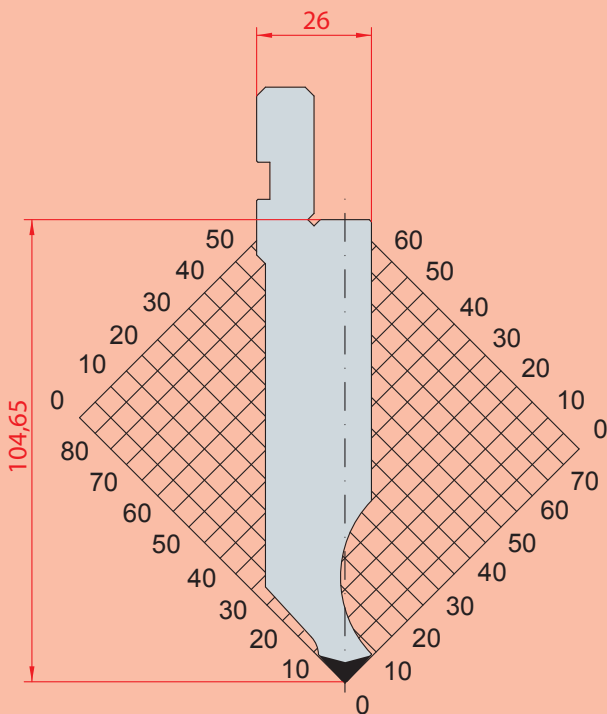

1281

$\alpha=85^\circ$  R=0.8 H=104.65 Max T/m=100

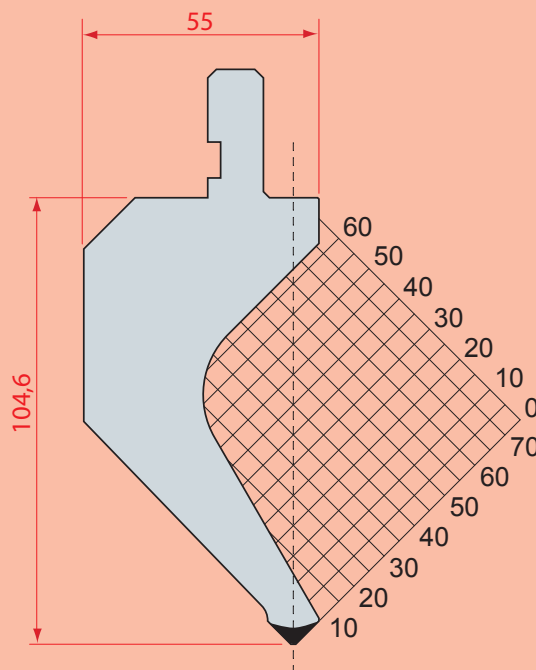

1172

$\alpha=85^\circ$  R=0.8 H= 104.6 Max T/m=50



RAZNÍK - 85° / PUNCHES 85°

- C45 zušlechtěná/quenched
- 42CrMo4
- C45

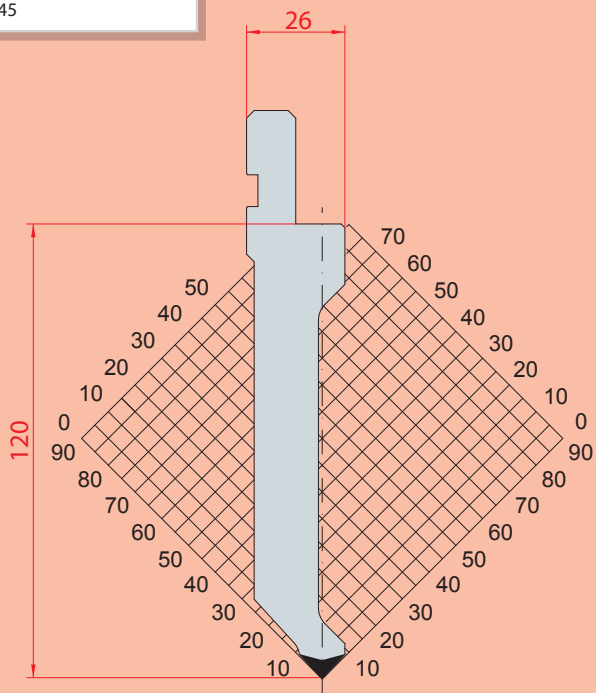

**1309**

$\alpha=85^\circ$  R=0.8 H=120.00 Max T/m=70

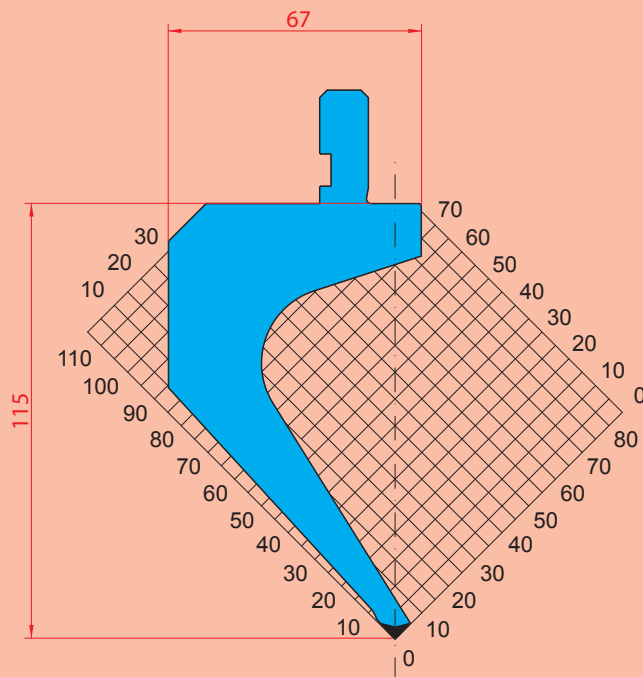

**1310**

$\alpha=85^\circ$  R=0.8 H=115.00 Max T/m=35

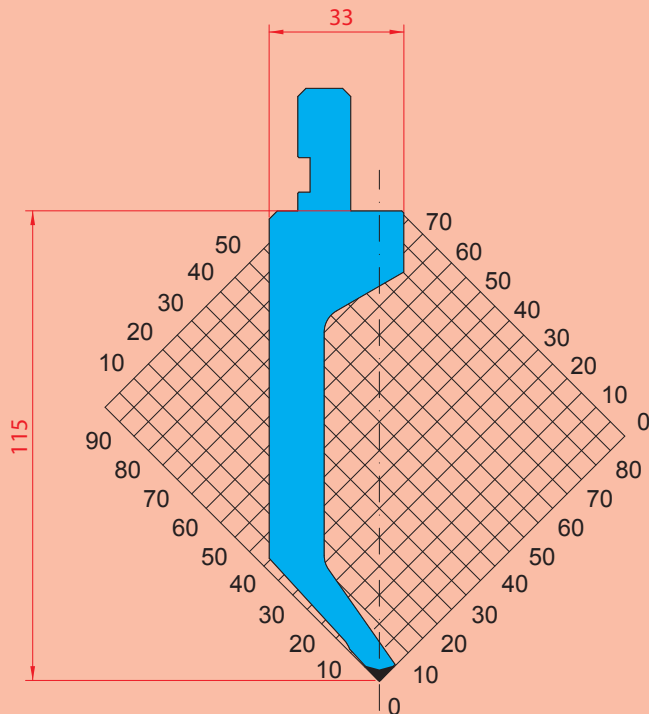

**1312**

$\alpha=85^\circ$  R=0.6 H=115.00 Max T/m=20

RAZNÍK - 60° / PUNCHES - 60°

- C45 zušlechtěná/quenched
- 42CrMo4
- C45

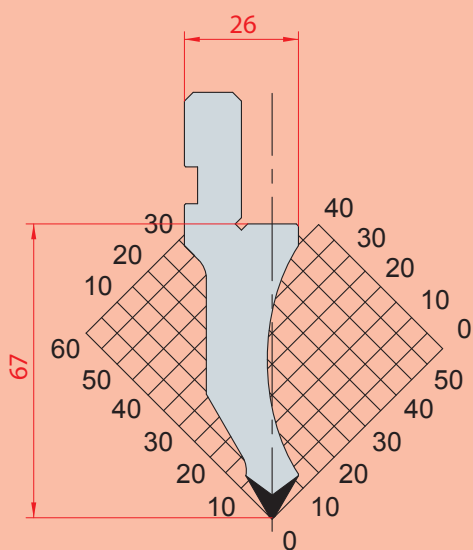

1026

$\alpha=60^\circ$  R=0.8 H=67.00 Max T/m=80

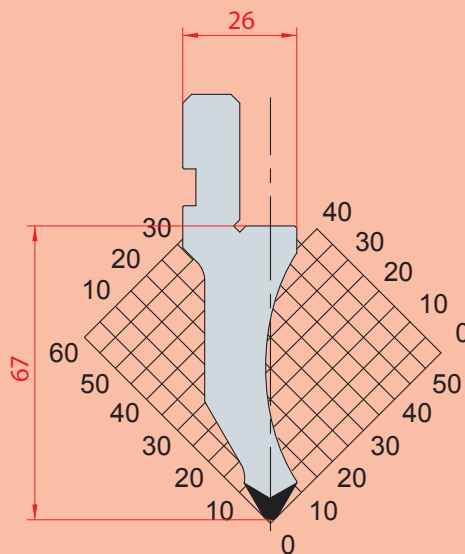

1027

$\alpha=60^\circ$  R=2 H=67.00 Max T/m=80

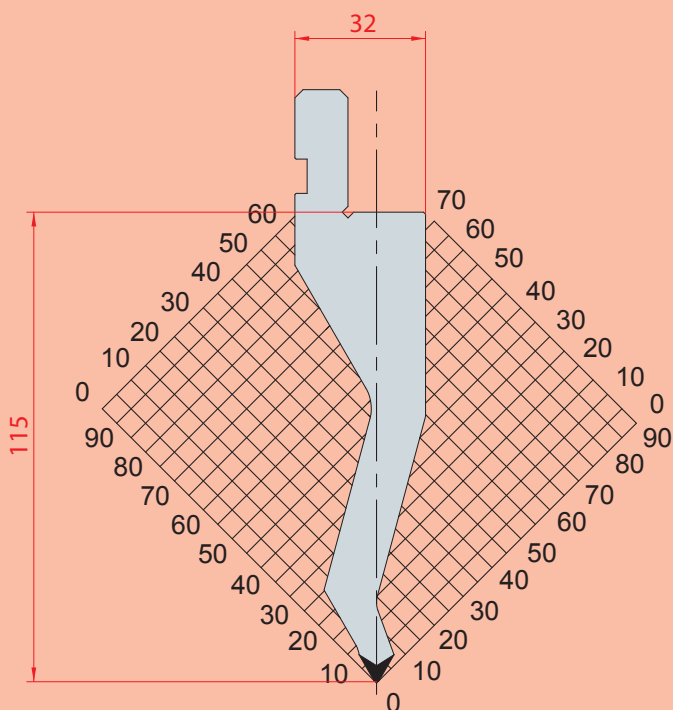

1191

$\alpha=60^\circ$  R=0.8 H=115.00 Max T/m=60

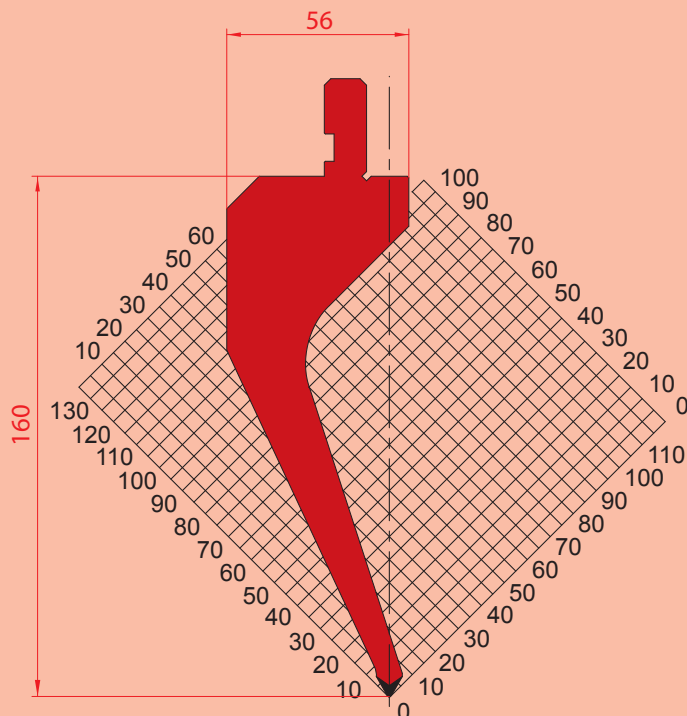

1190

$\alpha=60^\circ$  R=0.8 H=160.00 Max T/m=40

RAZNÍK - 60° / PUNCHES - 60°

- C45 zušlechtěná/quenched
- 42CrMo4
- C45

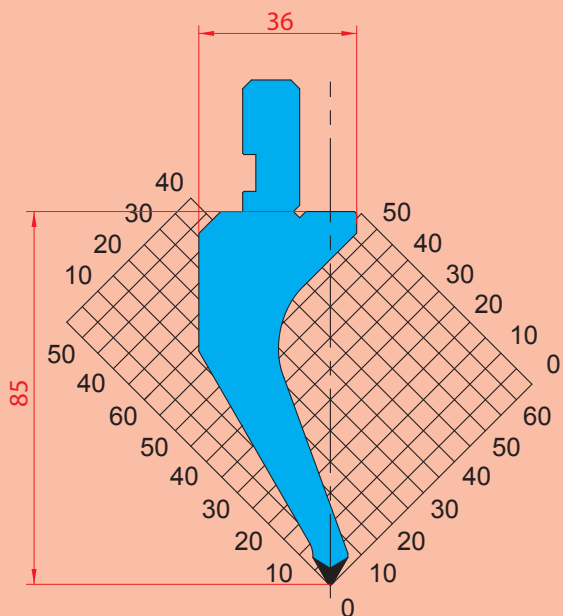

**1162**

$\alpha=60^\circ$  R=0.8 H=85.00 Max T/m=40

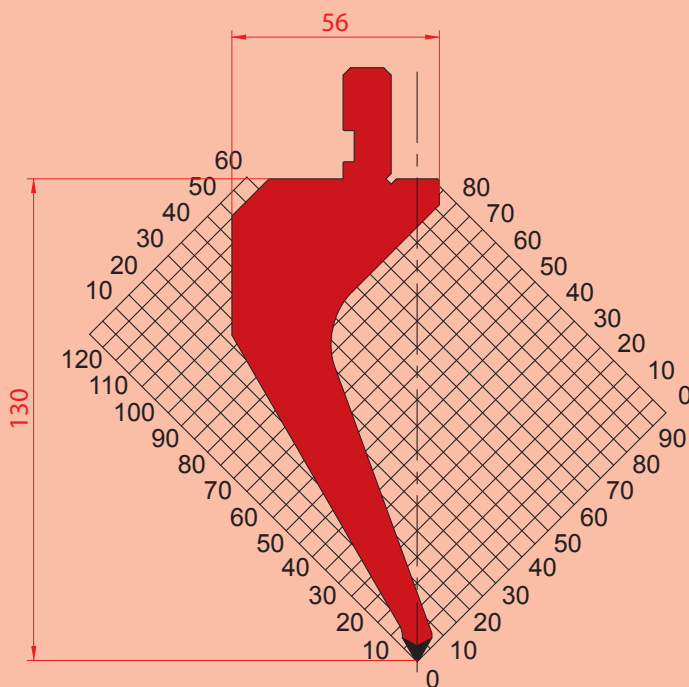

**1163**

$\alpha=60^\circ$  R=0.8 H=130.00 Max T/m=40

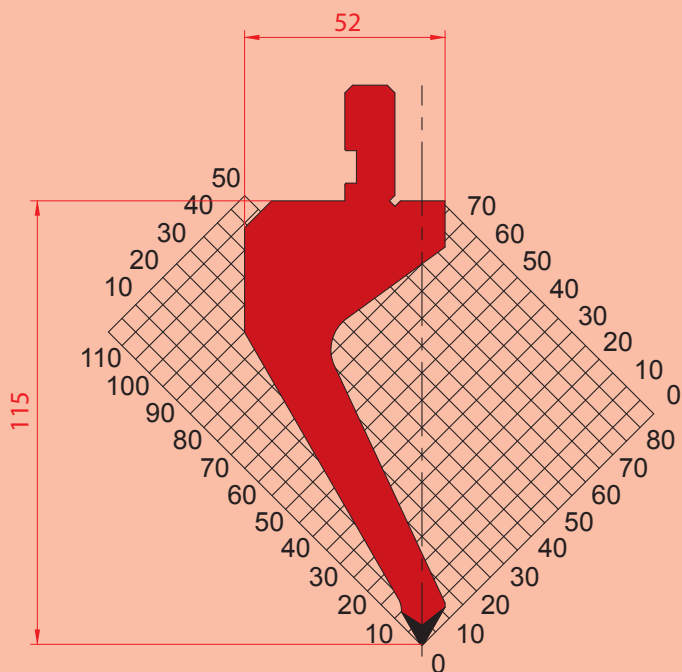

**1272**

$\alpha=60^\circ$  R=0.8 H=115.00 Max T/m=40

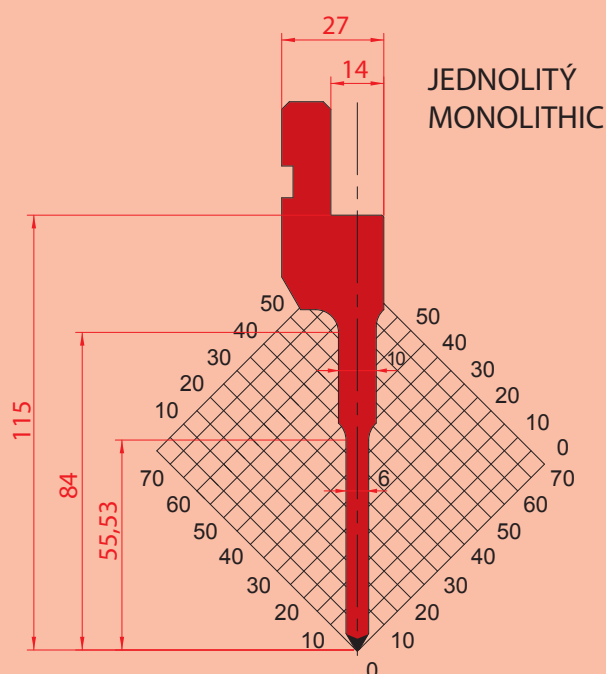

**1271**

$\alpha=60^\circ$  R=0.8 H=115.00 Max T/m=50

RAZNÍK - 60° / PUNCHES - 60°

■ C45 zušlechtěná/quenched  
 ■ 42CrMo4  
 ■ C45

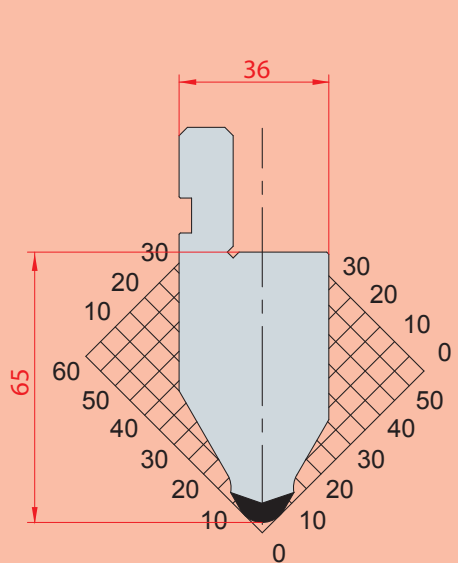

1032

$\alpha=60^\circ$  R=6 H=65.00 Max T/m=120

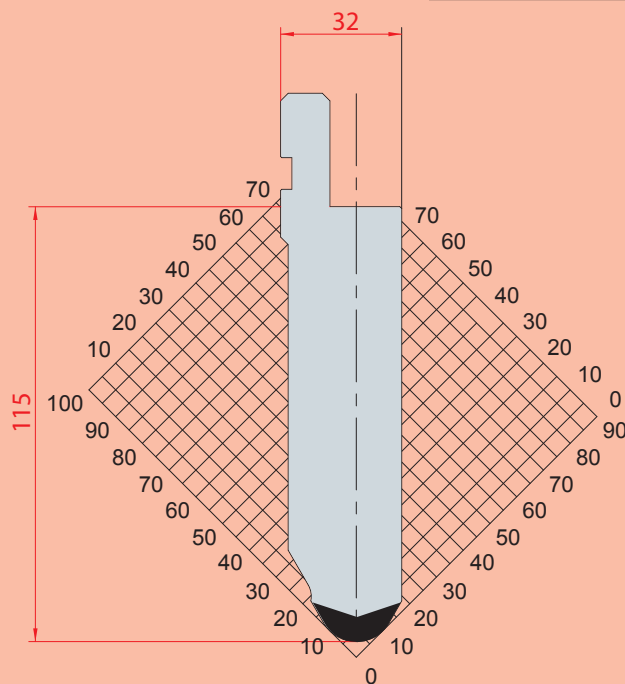

1283

$\alpha=60^\circ$  R=10 H=115.00 Max T/m=150

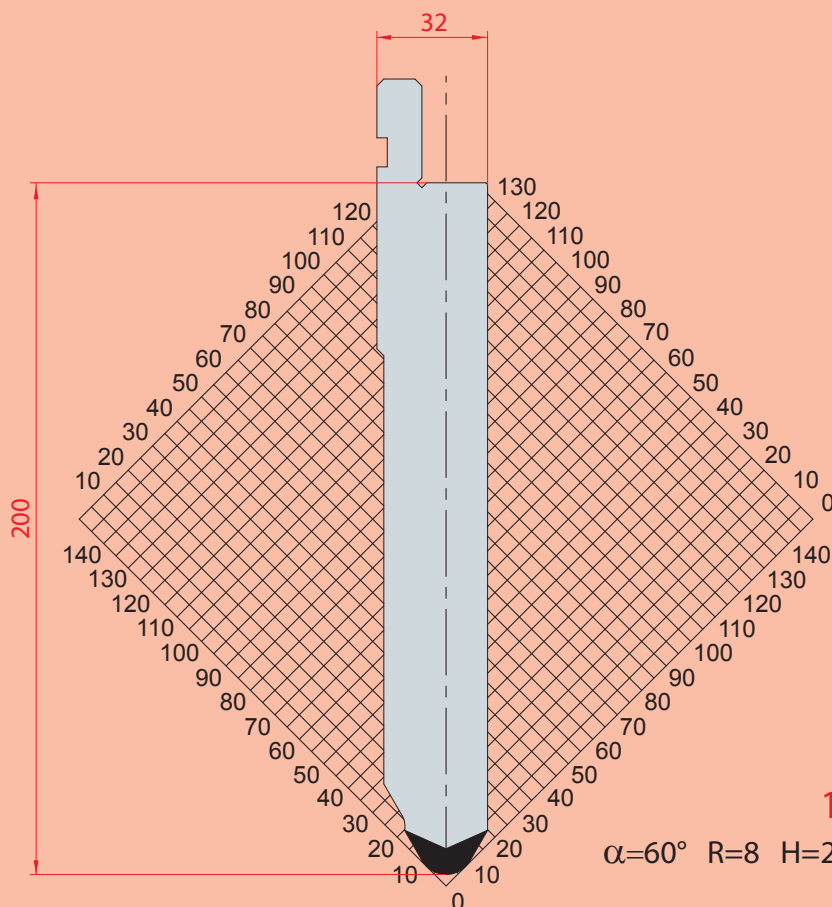

1293

$\alpha=60^\circ$  R=8 H=200.00 Max T/m=150

RAZNÍK - 60° / PUNCHES - 60°

- C45 zušlechtěná/quenched
- 42CrMo4
- C45

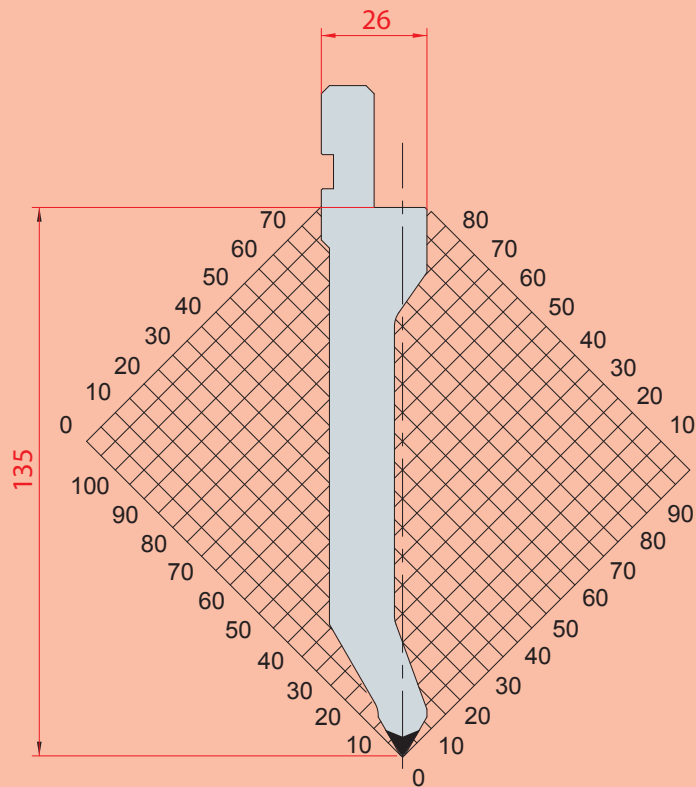

1284

$\alpha=60^\circ$  R=0.8 H=135.00 Max T/m=70



RAZNÍK - 45° / PUNCHES - 45°

■	C45 zušlechtěná/quenched
■	42CrMo4
■	C45

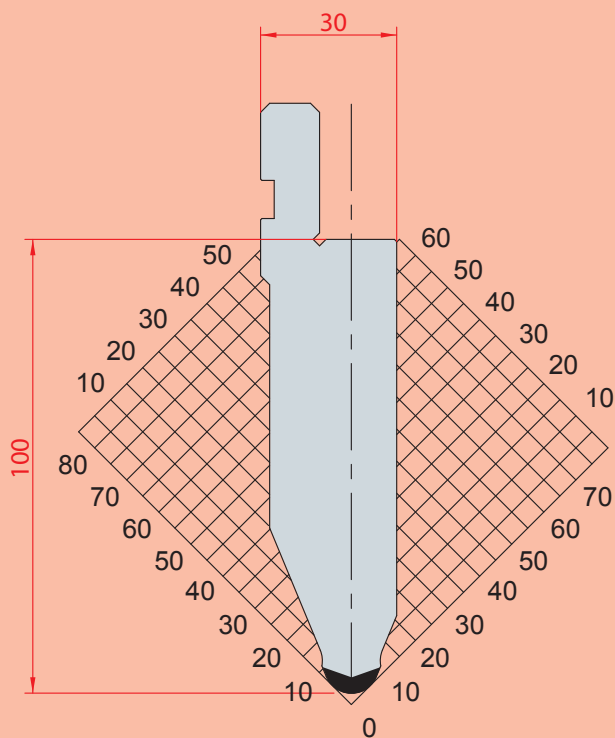

**1053**

$\alpha=45^\circ$  R=6 H=100.00 Max T/m=100

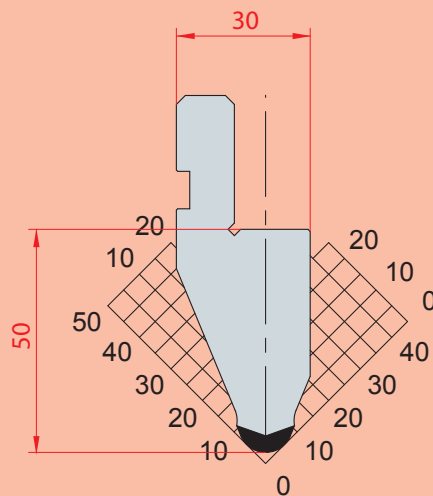

**1054**

$\alpha=45^\circ$  R=6 H=50.00 Max T/m=100

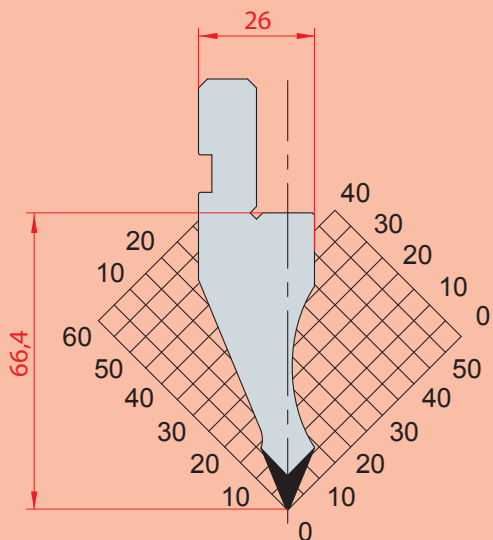

**1024**

$\alpha=45^\circ$  R=0.5 H=66.40 Max T/m=80

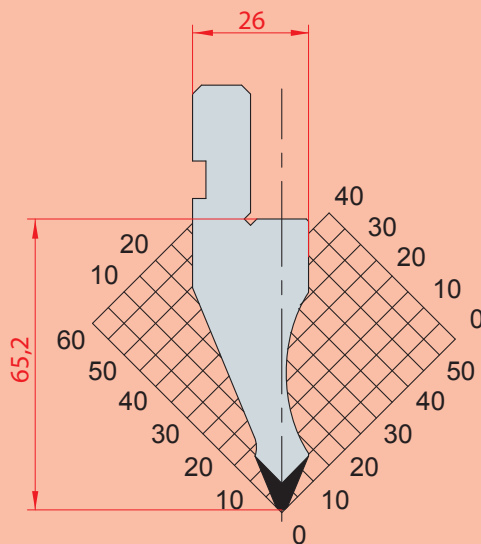

**1025**

$\alpha=45^\circ$  R=1.5 H=65.20 Max T/m=80

RAZNÍK - 35° / PUNCHES - 35°

- C45 zušlechtěná/quenched
- 42CrMo4
- C45

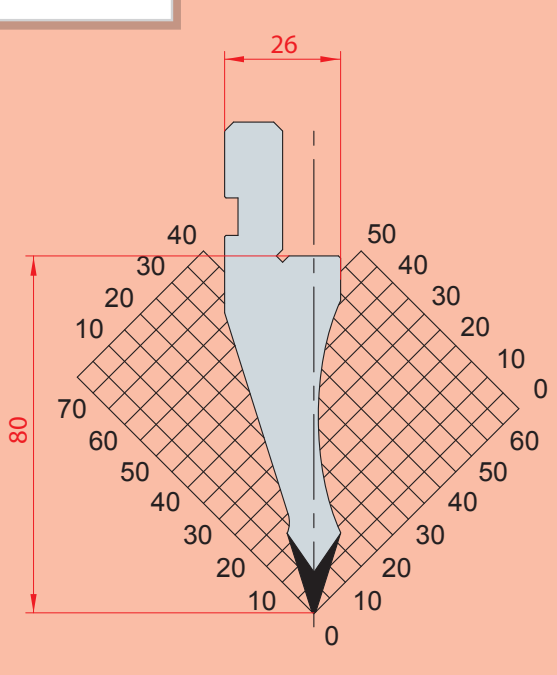

**1035**

$\alpha=35^\circ$  R=0.5 H=80.00 Max T/m=70

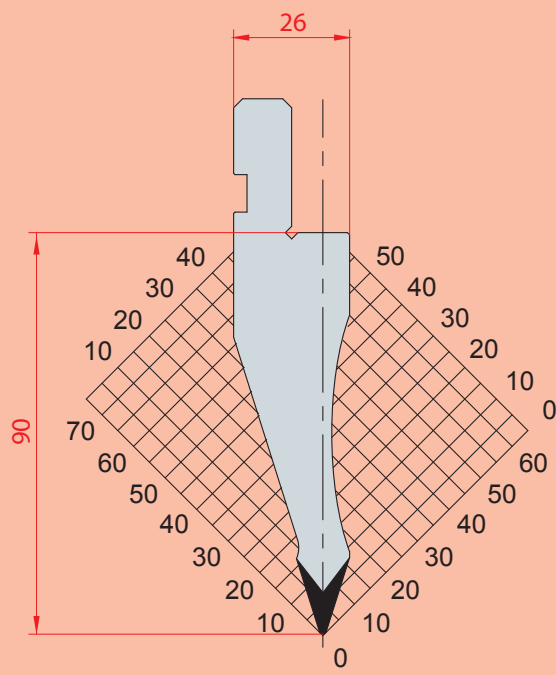

**1047**

$\alpha=35^\circ$  R=0.8 H=90.00 Max T/m=70

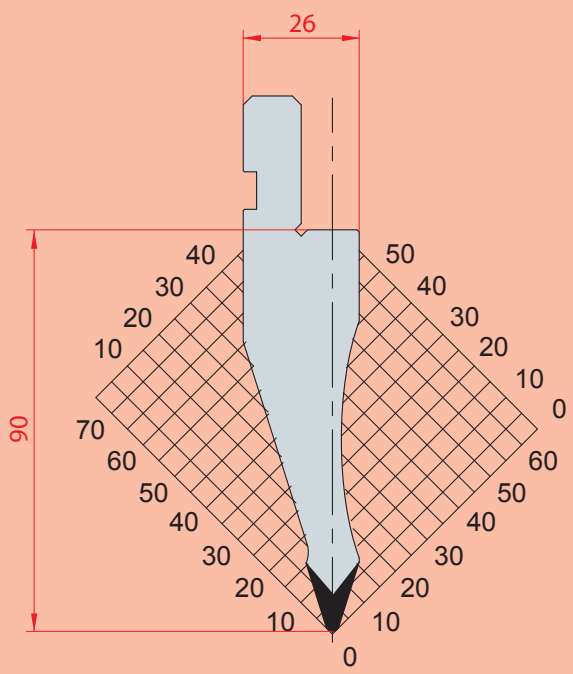

**1282**

$\alpha=35^\circ$  R=1.5 H=90.00 Max T/m=70

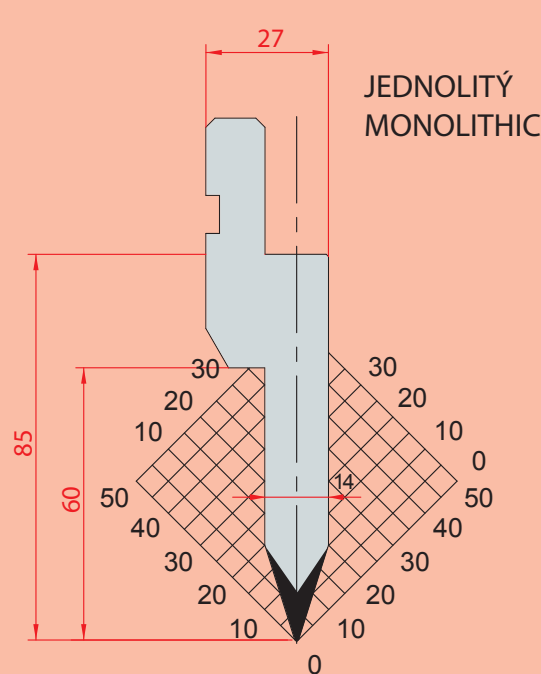

JEDNOLITÝ  
MONOLITHIC

**1034**

$\alpha=35^\circ$  P=0.8 H=85.00 Max T/m=100

RAZNÍK - 30° / PUNCHES - 30°

■ C45 zušlechtěná/quenched  
■ 42CrMo4  
■ C45

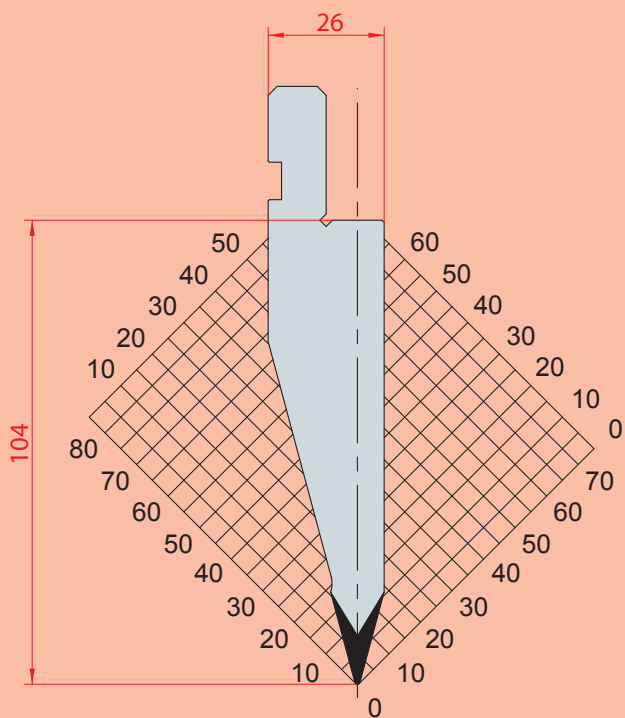

**1193**

$\alpha=30^\circ$  R=0.6 H=104.00 Max T/m=100

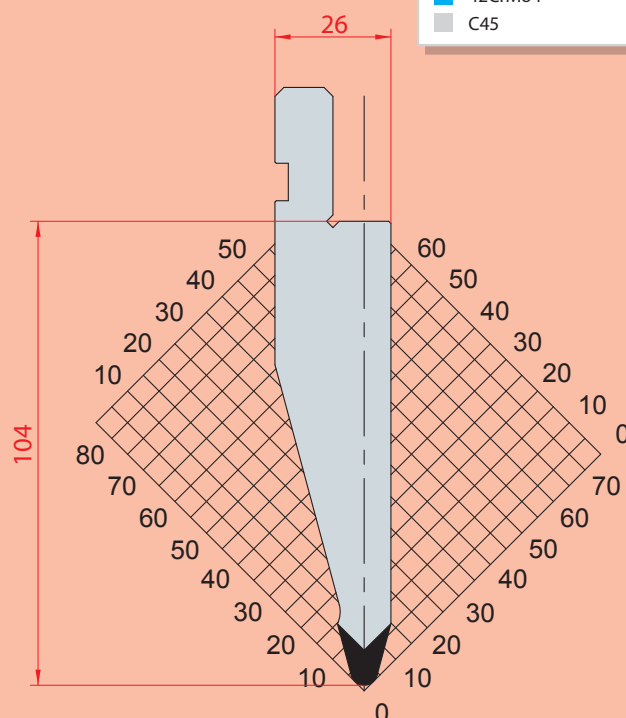

**1289**

$\alpha=30^\circ$  R=3 H=104.00 Max T/m=100

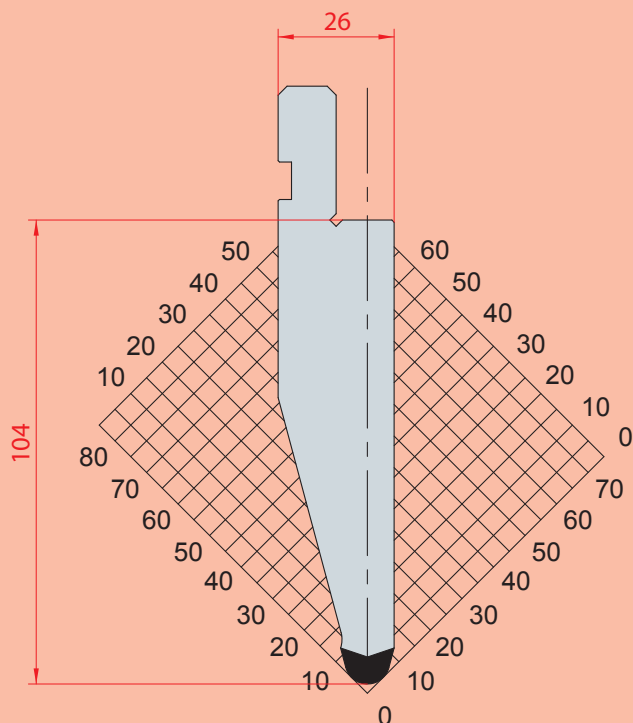

**1194**

$\alpha=30^\circ$  R=5 H=104.00 Max T/m=100

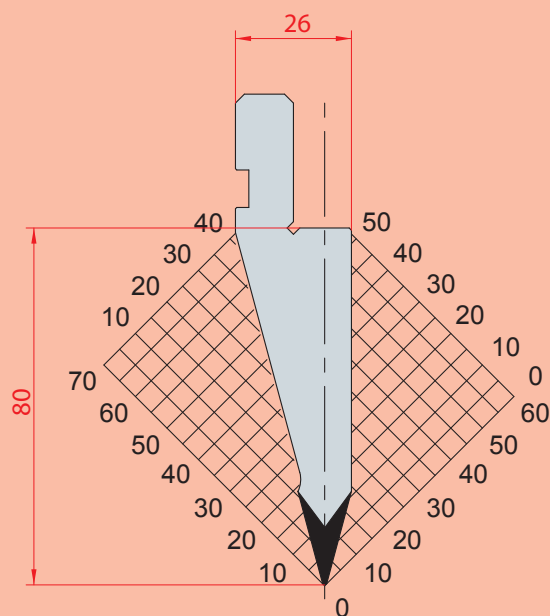

**1056**

$\alpha=30^\circ$  R=0.5 H=80.00 Max T/m=100



RAZNÍK - 30° / PUNCHES - 30°

- C45 zušlechtěná/quenched
- 42CrMo4
- C45

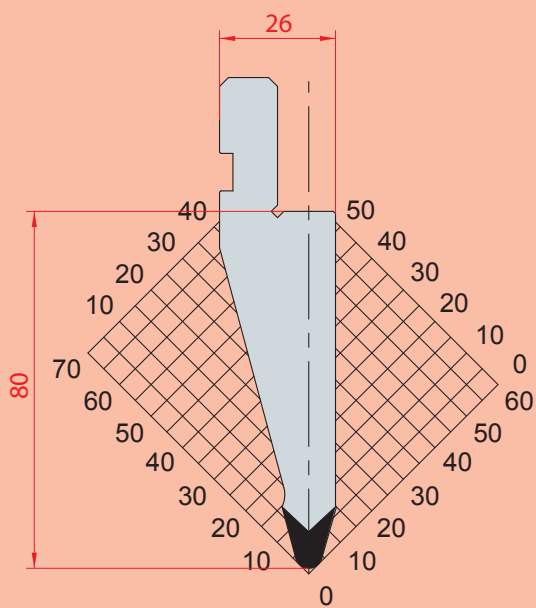

1057

$\alpha=30^\circ$  R=3 H=80.00 Max T/m=100

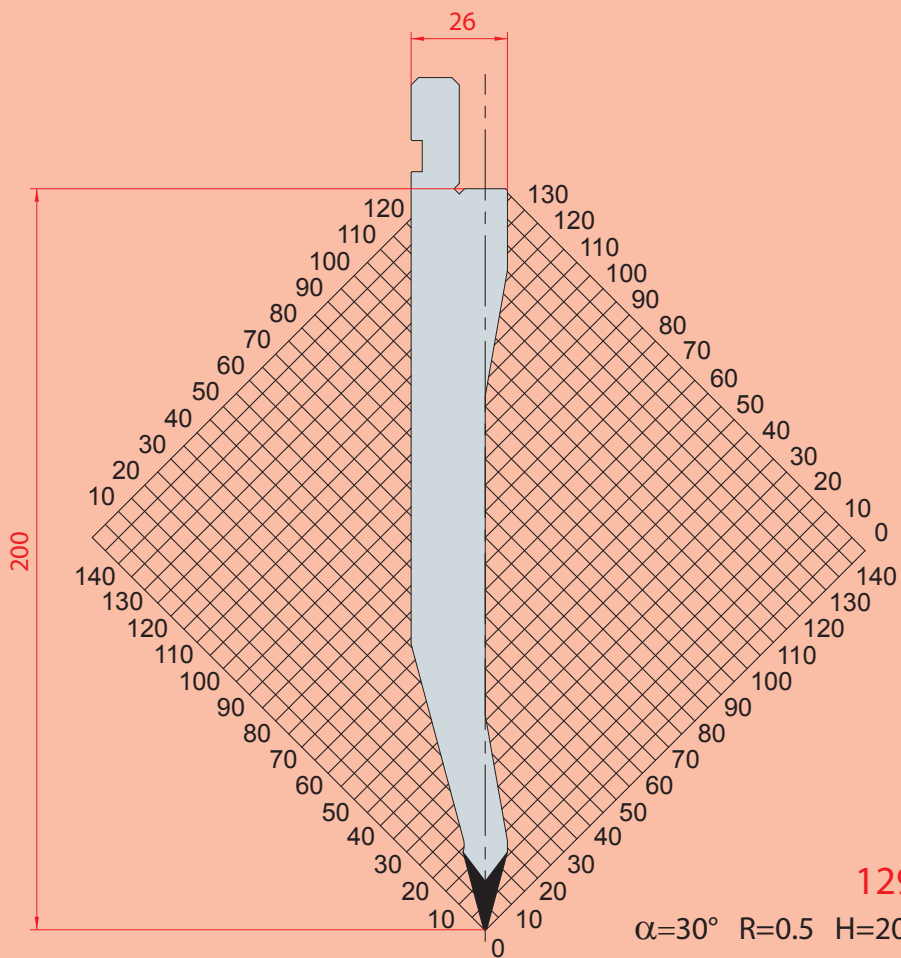

1292

$\alpha=30^\circ$  R=0.5 H=200.00 Max T/m=50

RAZNÍK - 30° / PUNCHES - 30°

<span style="color: red;">■</span>	C45 zušlechtěná/quenched
<span style="color: lightblue;">■</span>	42CrMo4
<span style="color: gray;">■</span>	C45

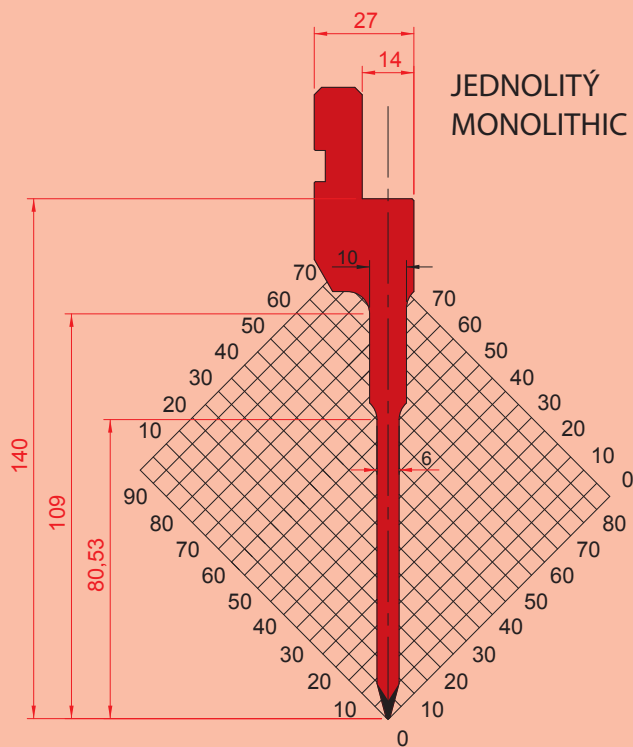

JEDNOLITÝ  
MONOLITHIC

1086

$\alpha=30^\circ$  R=0.6 H=140.00 MaxT/m=40

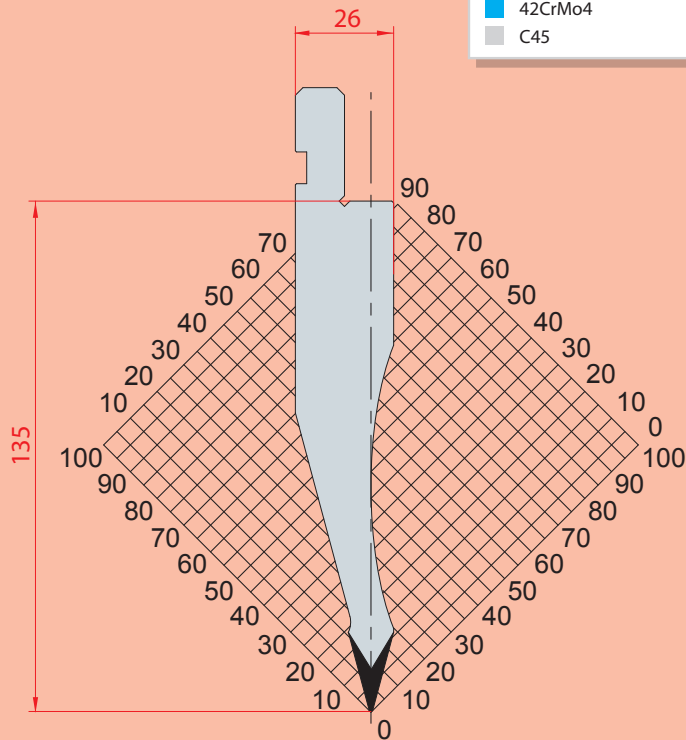

1052

$\alpha=30^\circ$  R=0.5 H=135.00 MaxT/m=50

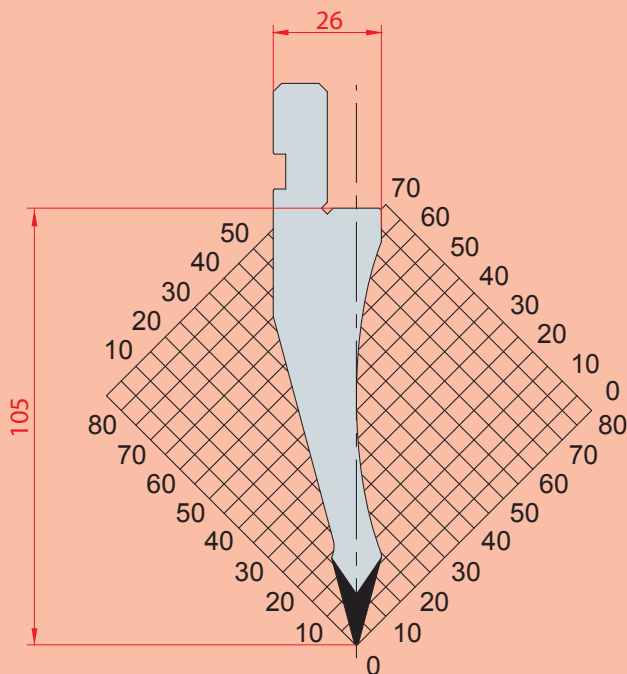

1055

$\alpha=30^\circ$  R=0.5 H=105.00 MaxT/m=50

RAZNÍK - 26° / PUNCHES - 26°

- C45 zušlechťená/quenched
- 42CrMo4
- C45

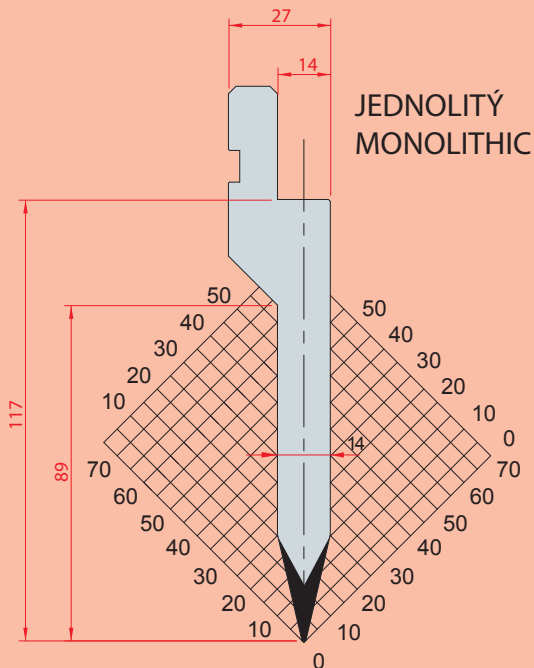

**1033**

$\alpha=26^\circ$  P=1 H=117.00 Max T/m=100

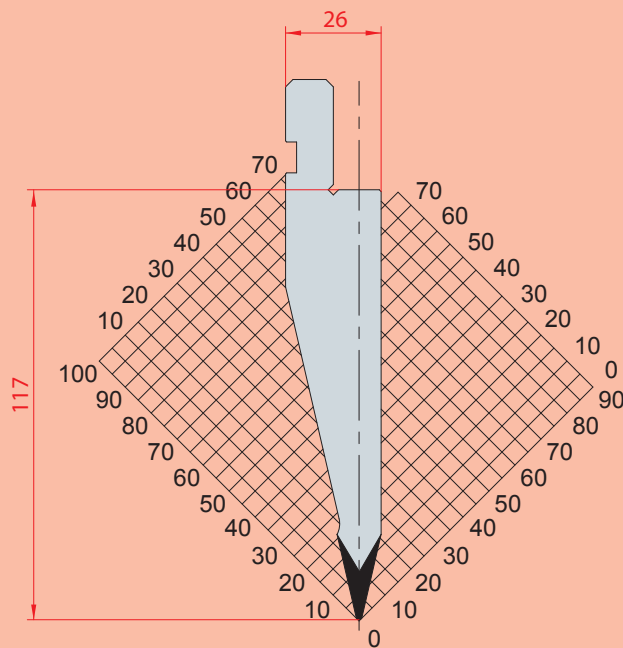

**1178**

$\alpha=26^\circ$  R=0.8 H=117.00 Max T/m=100

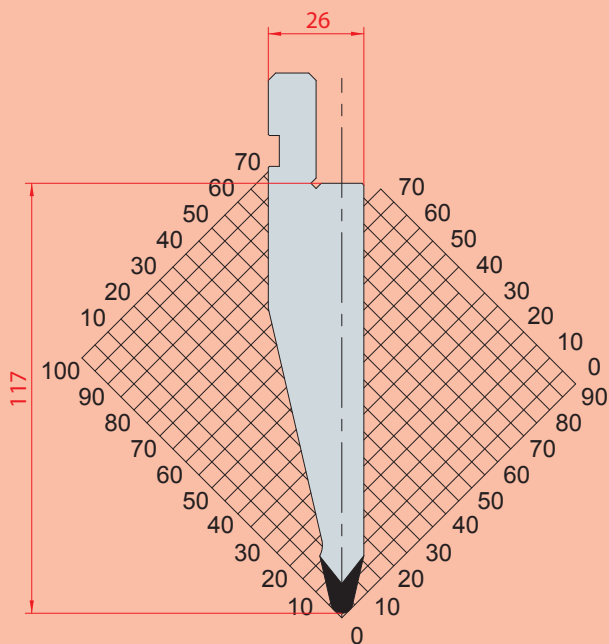

**1192**

$\alpha=26^\circ$  R=3 H=117.00 Max T/m=100

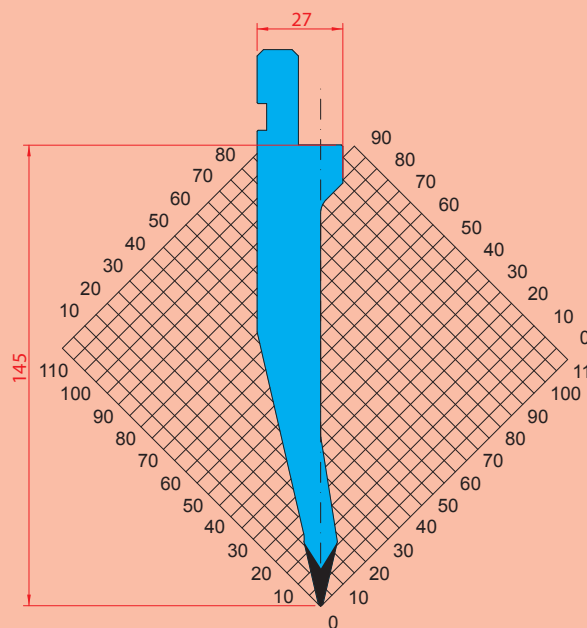

**1311**

$\alpha=26^\circ$  R=0.8 H=145.00 Max T/m=100