

RAZNÍKY / PUNCHES

STANDARDNÍ DĚLENÍ /  
STANDARD SEGMENTATION

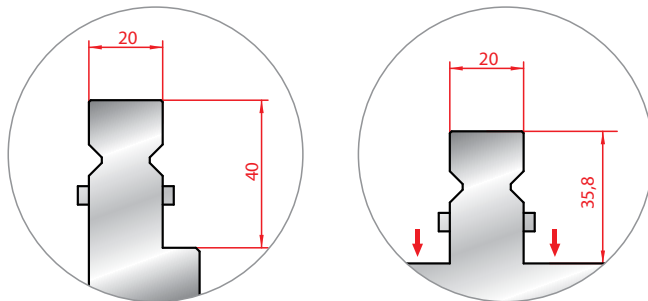

Safety klik je vhodný pro rzníky, které nepřekročí váhu 13,5 Kg.  
Safety button on demand when the weight of the tool is less than 13,5 Kg.

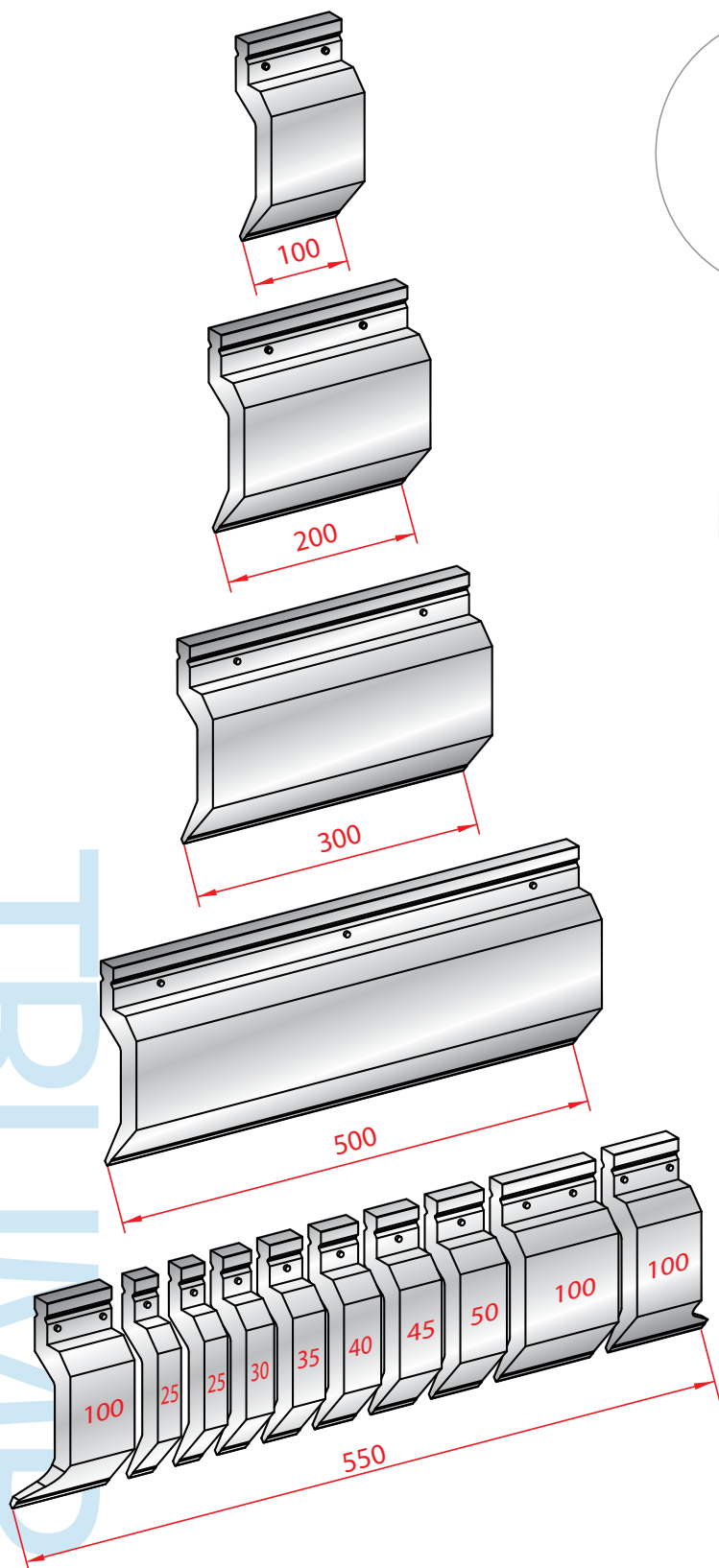
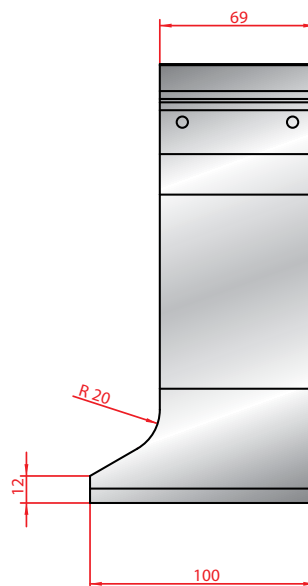

UPRAVENÝ ROH  
MILLED HORN

ÚPRAVY NA PŘÁNÍ / MODIFICATIONS ON REQUEST

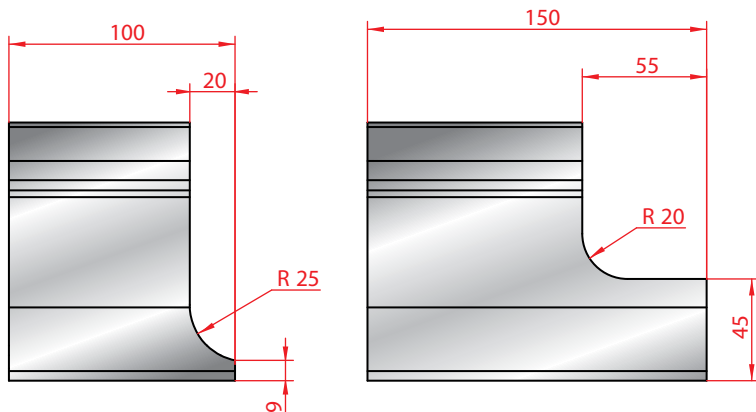

SPECIÁLNÍ ROHY /  
SPECIAL HORNS



SPECIÁLNÍ DĚLENÍ /  
SPECIAL SEGMENTATION

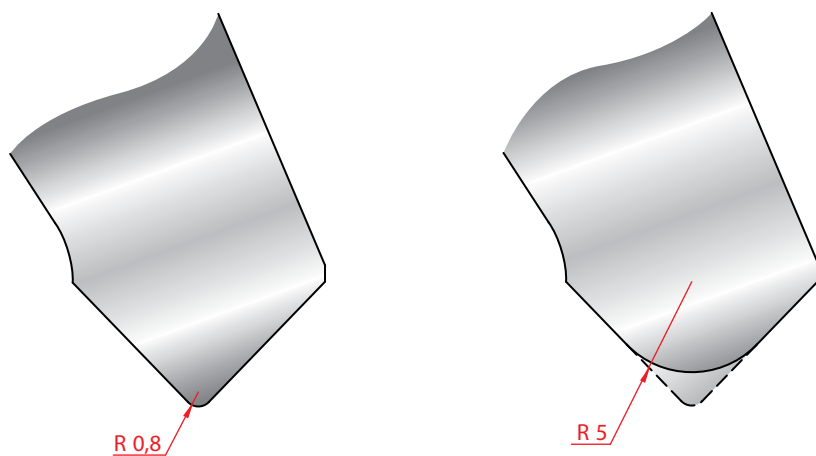

ÚPRAVA RÁDIUSU /  
RADIUS MODIFICATION

TRUMPF

RAZNÍKY / PUNCHES

PRO RAZNÍKY / FOR PUNCHES:  
 1233 - 1234 - 1235 - 1236 - 1237 - 1238  
 1295 - 1302 - 1308 - 1313 - 1314



550

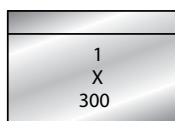
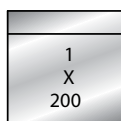

1050

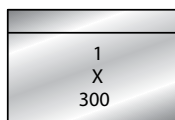
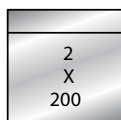

1250

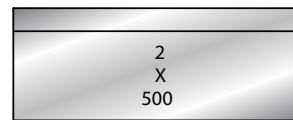
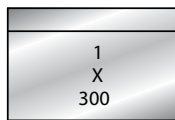
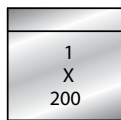

2050

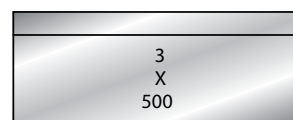
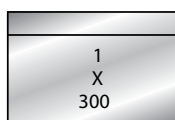
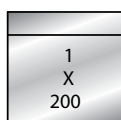

2550

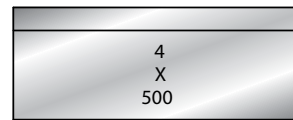
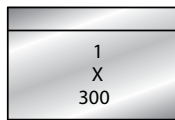
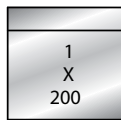
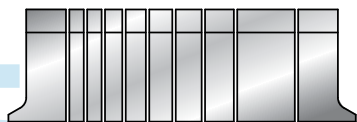

3050

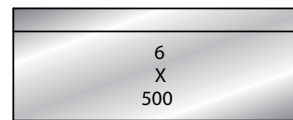
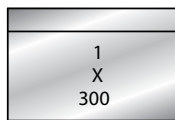
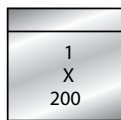

4050

TRUMPF

RAZNÍKY / PUNCHES

PRO RAZNÍKY / FOR PUNCHES:  
1294 - 1303



550

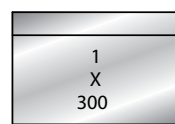
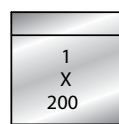

1050

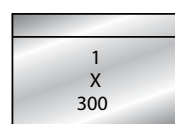
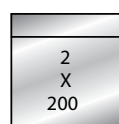

1250

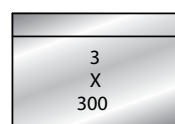
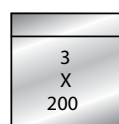

2050

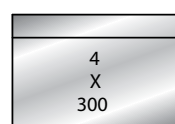
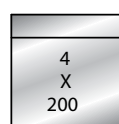

2550

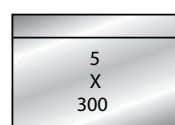
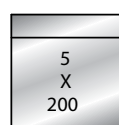

3050

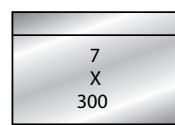
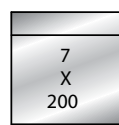











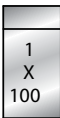
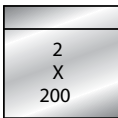

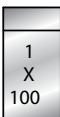
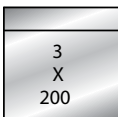
4050

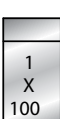
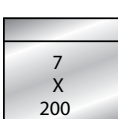
TRUMPF

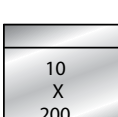
RAZNÍKY / PUNCHES

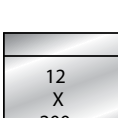
PRO RAZNÍKY / FOR PUNCH:  
1315

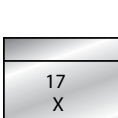
			550
	 1 X 100	 2 X 200	1050
	 1 X 100	 3 X 200	1250
	 1 X 100	 7 X 200	2050
		 10 X 200	2550
	 1 X 100	 12 X 200	3050
	 1 X 100	 17 X 200	4050

TRUMPF

RAZNÍKY - 86° / PUNCHES - 86°

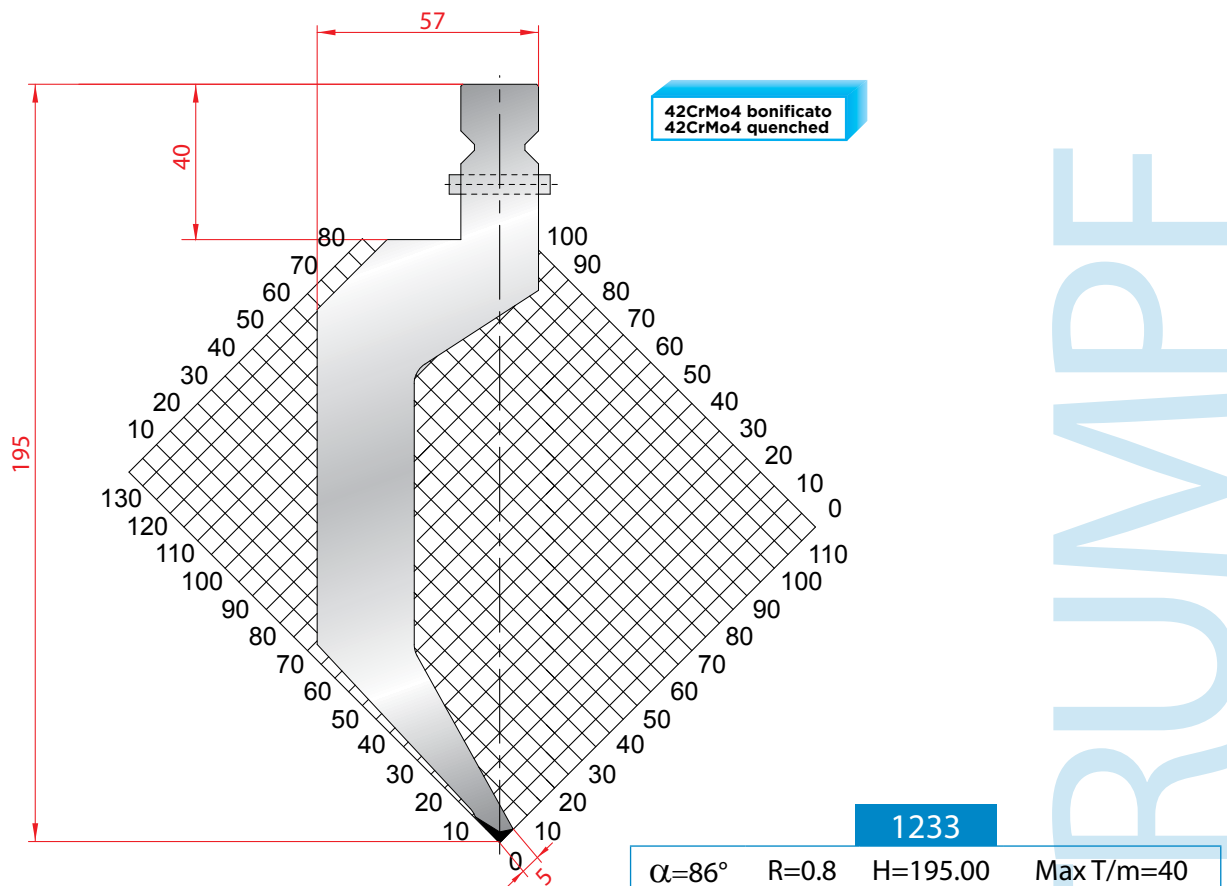
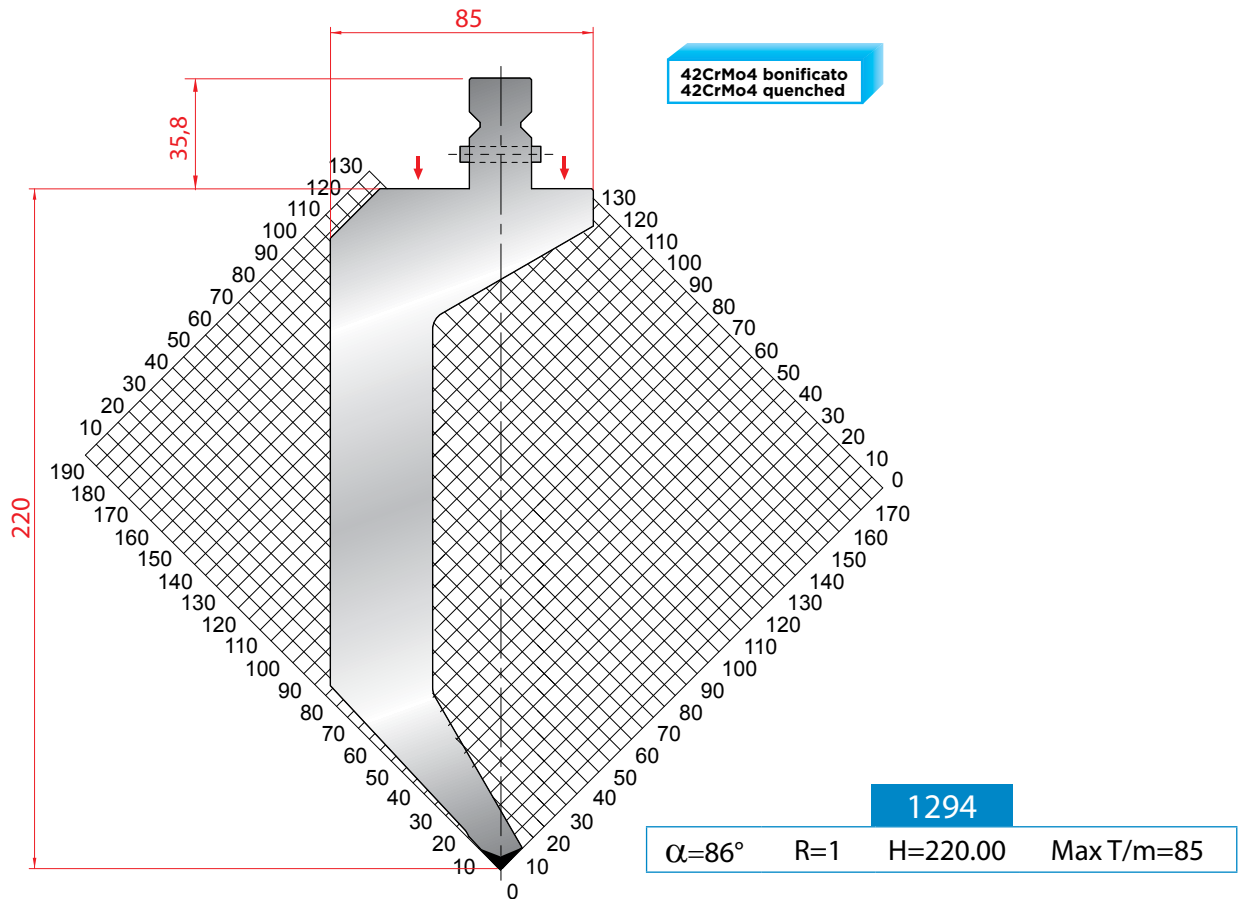

TRUMPF

RAZNÍKY - 86° / PUNCHES - 86°

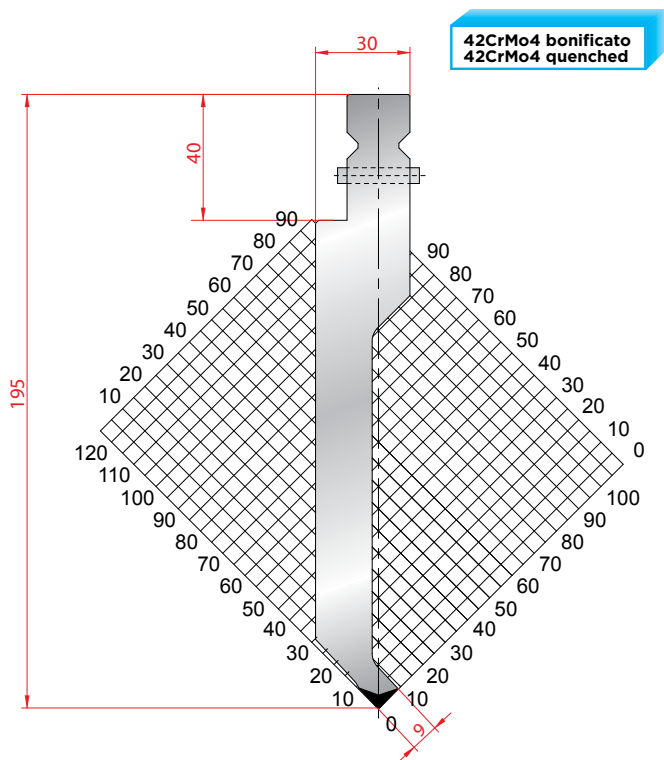

1235

$\alpha=86^\circ$  R=0.8 H=195.00 Max T/m=100

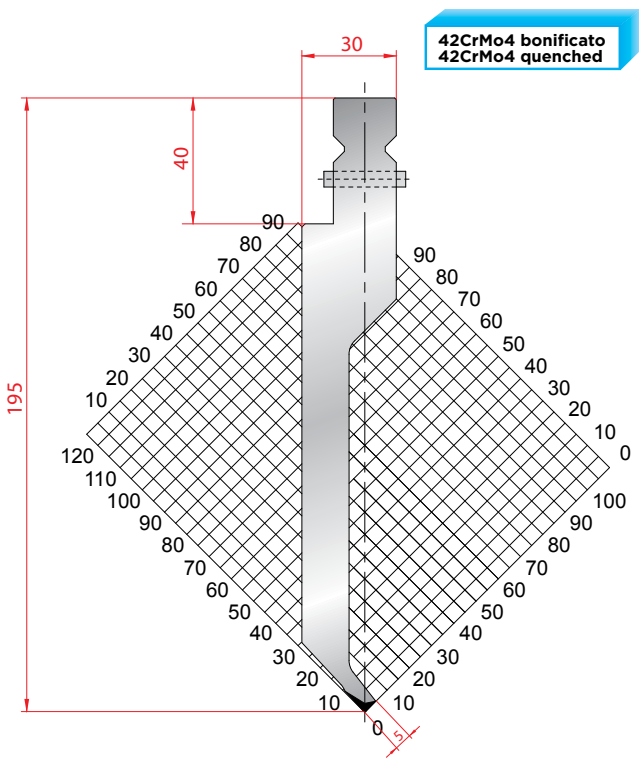

1234

$\alpha=86^\circ$  R=0.6 H=195.00 Max T/m=30



TRUMPF

RAZNÍKY - 86° / PUNCHES - 86°

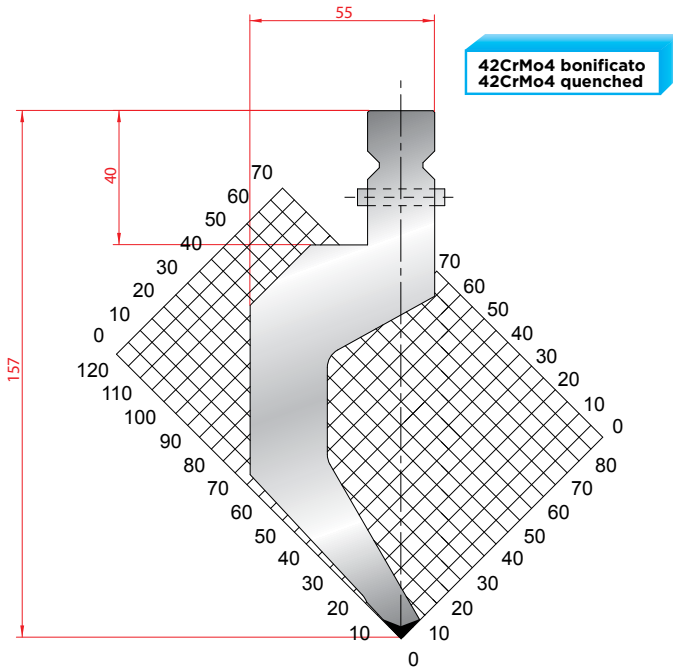

1314

$\alpha=86^\circ$  R=1 H=157.00 Max T/m=65

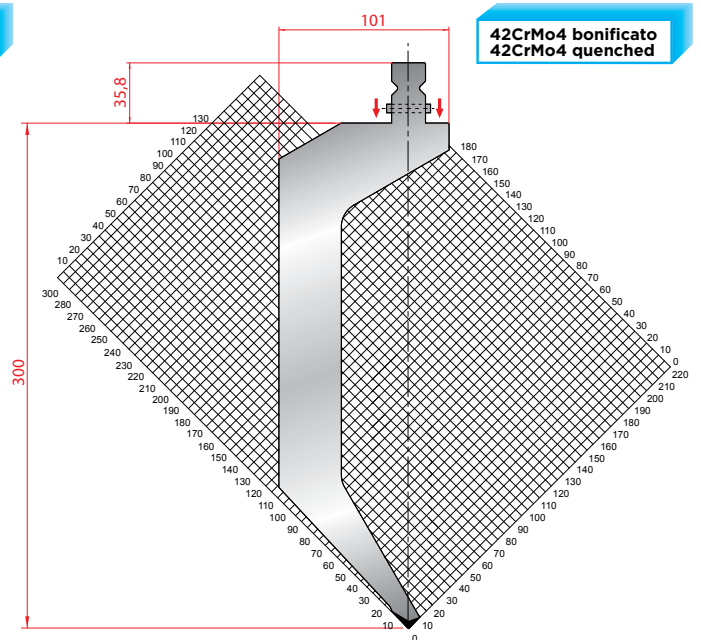

1315

$\alpha=86^\circ$  R=1 H=300.00 Max T/m=80

MÍSTO TLAKU BERANU/ SHOULDER LOAD (↓)

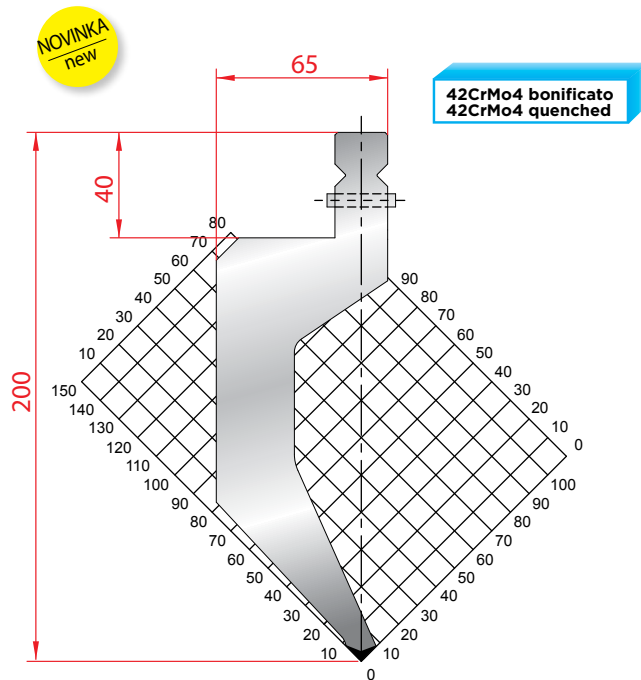

1320

$\alpha=86^\circ$  R=1.5 H=200.00 Max T/m=100

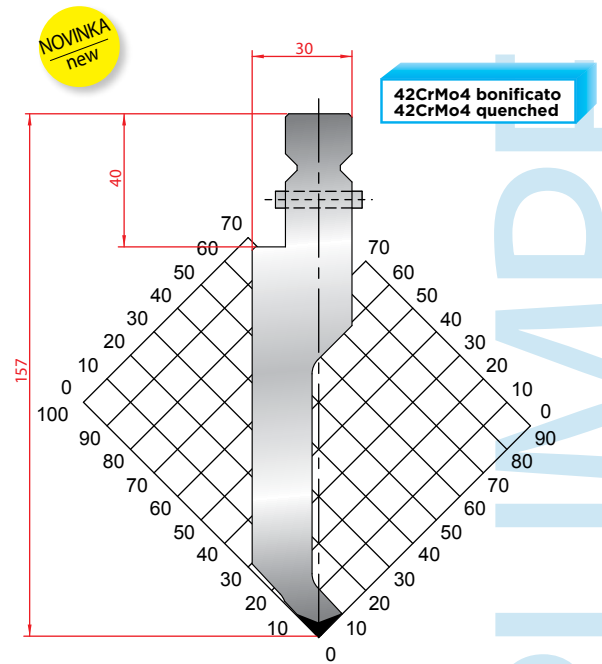

1317

$\alpha=86^\circ$  R=1 H=157.00 Max T/m=100



RAZNÍKY - 80° / PUNCHES - 80°

NOVINKA  
new

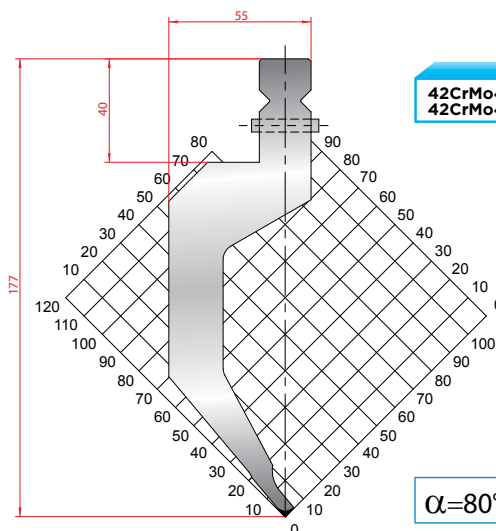

42CrMo4 bonificato  
42CrMo4 quenched

1319

$\alpha=80^\circ$  R=0,5 H=177.00 Max T/m=20

RAZNÍKY - 60° / PUNCHES - 60°

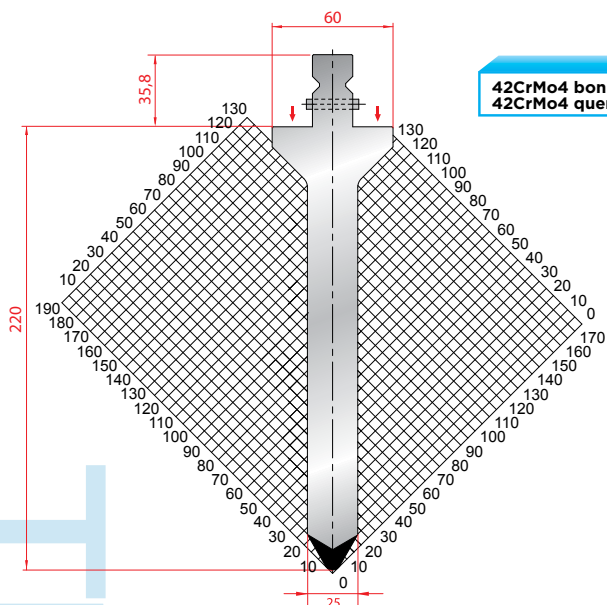

42CrMo4 bonificato  
42CrMo4 quenched

1303

$\alpha=60^\circ$  R=4 H=220.00 Max T/m=100

MÍSTO TLAKU BERANU / SHOULDER

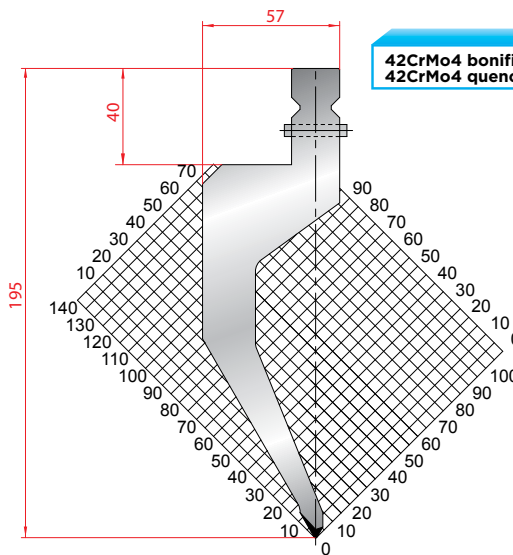

42CrMo4 bonificato  
42CrMo4 quenched

1236

$\alpha=60^\circ$  R=0.8 H=195.00 Max T/m=40

NOVINKA  
new

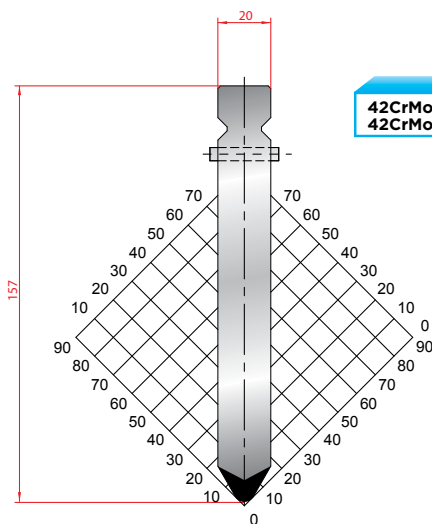

42CrMo4 bonificato  
42CrMo4 quenched

1318

$\alpha=60^\circ$  R=4 H=157.00 Max T/m=100

RAZNÍKY - 28° / PUNCHES - 28°

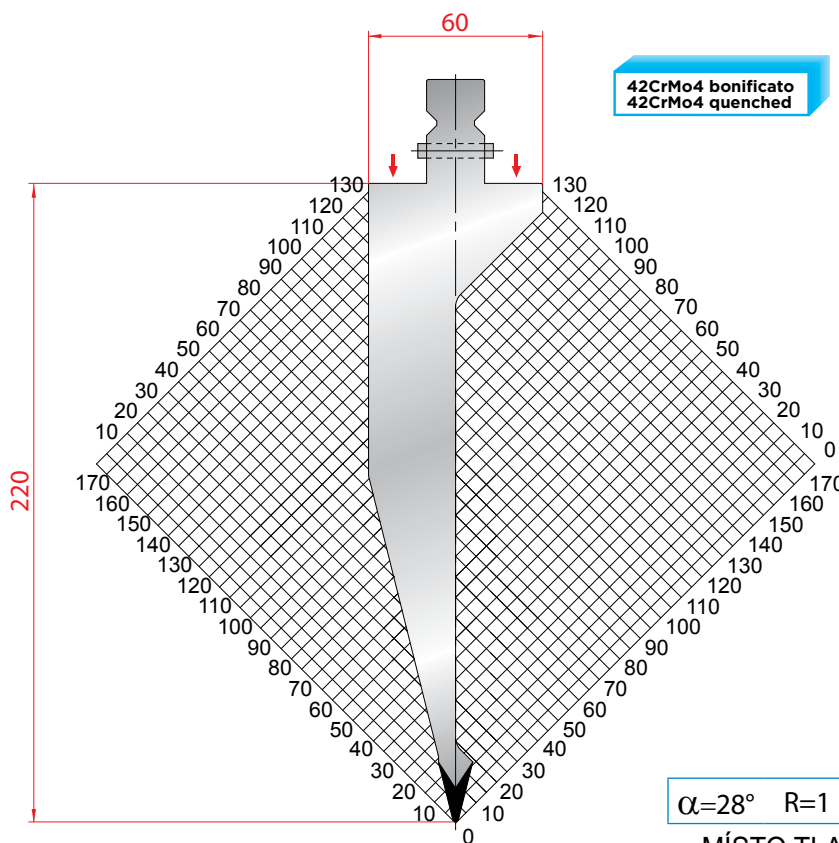
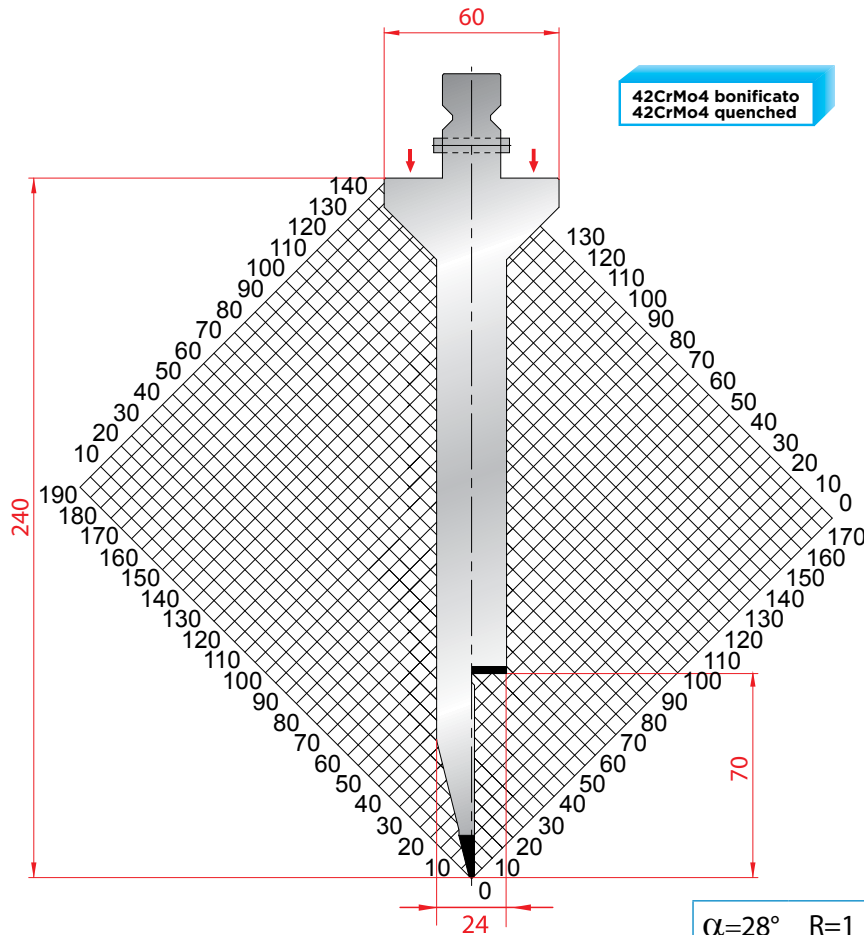

TRUMPF

RAZNÍKY - 28° / PUNCHES - 28°

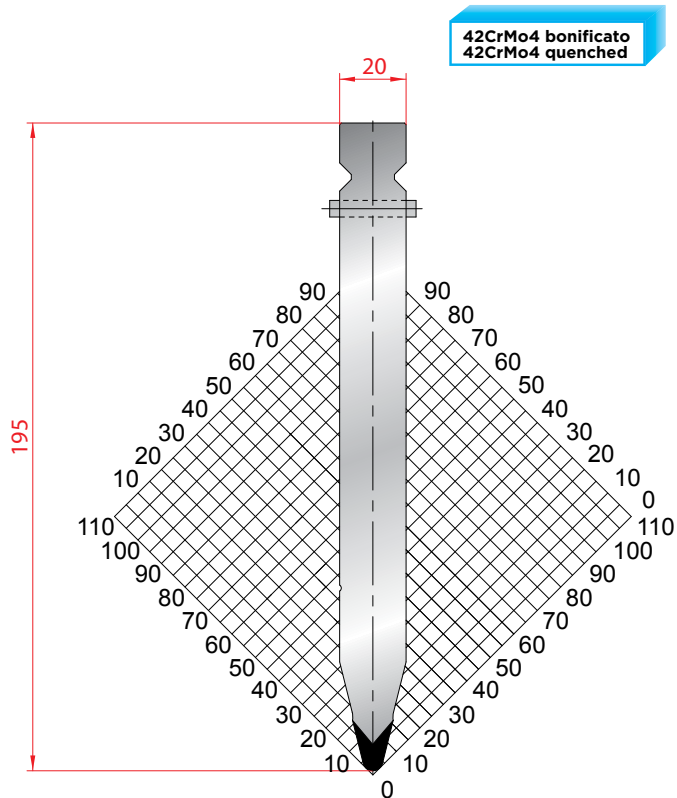

1237

$\alpha=28^\circ$  R=3 H=195.00 Max T/m=100

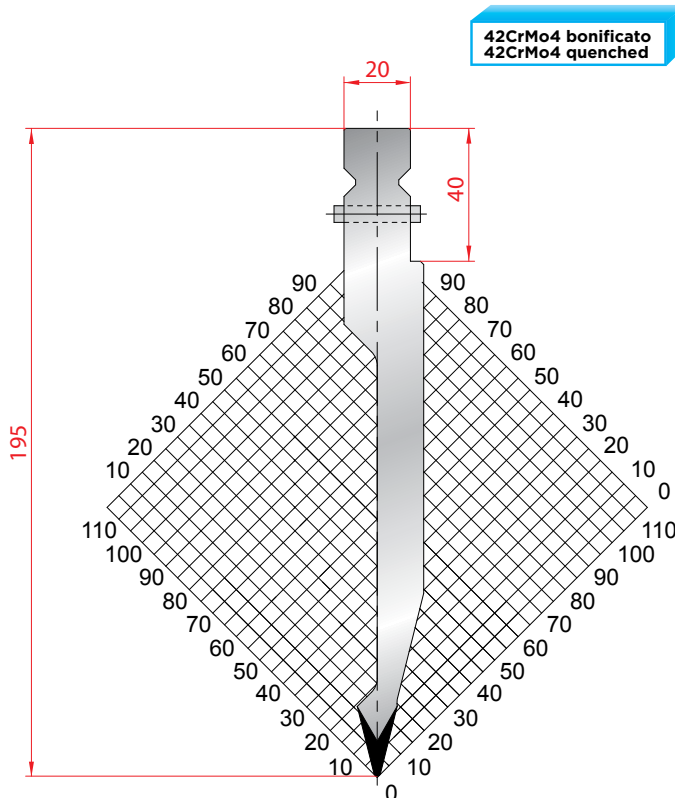

1238

$\alpha=28^\circ$  R=1 H=195.00 Max T/m=80

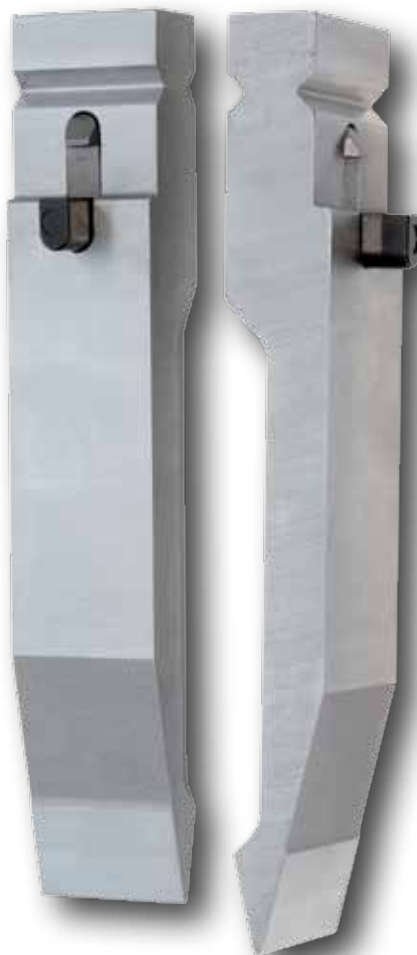

TRUMPF

RAZNÍKY - 28° / PUNCHES - 28°

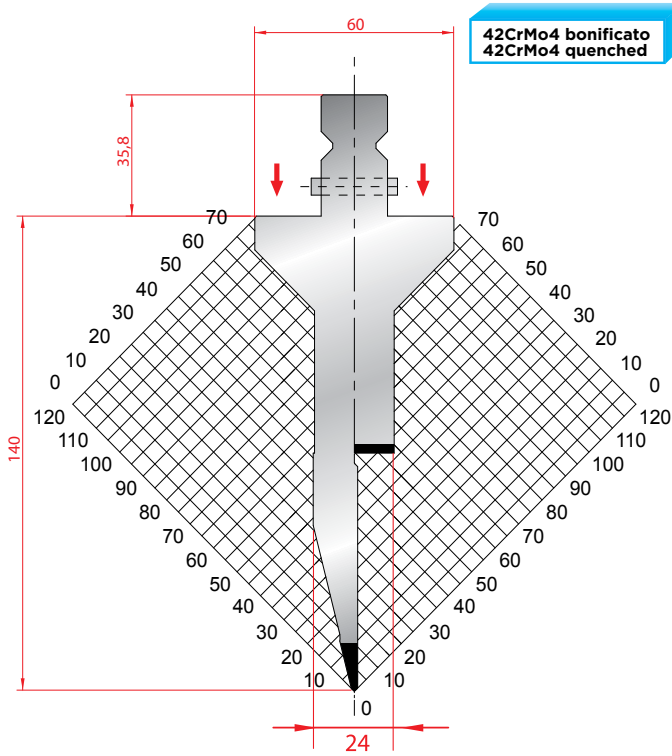

1308

$\alpha=28^\circ$  R=1 H=140.00 Max T/m=40

MÍSTO TLAKU BERANU/ SHOULDER

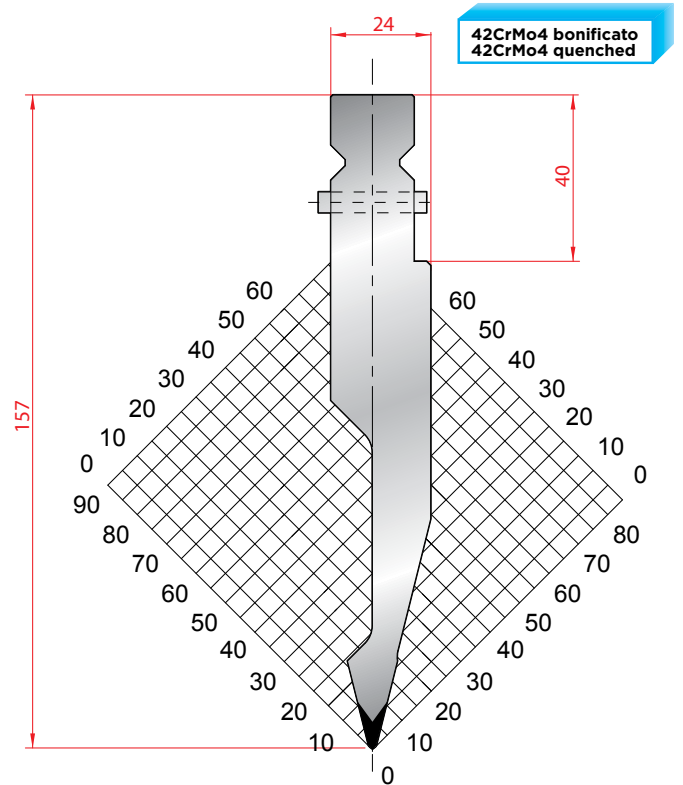

1313

$\alpha=28^\circ$  R=1 H=157.00 Max T/m=80

MÍSTO TLAKU BERANU/ SHOULDER

RAZNÍKY - 26° / PUNCHES - 26°

NOVINKA  
new

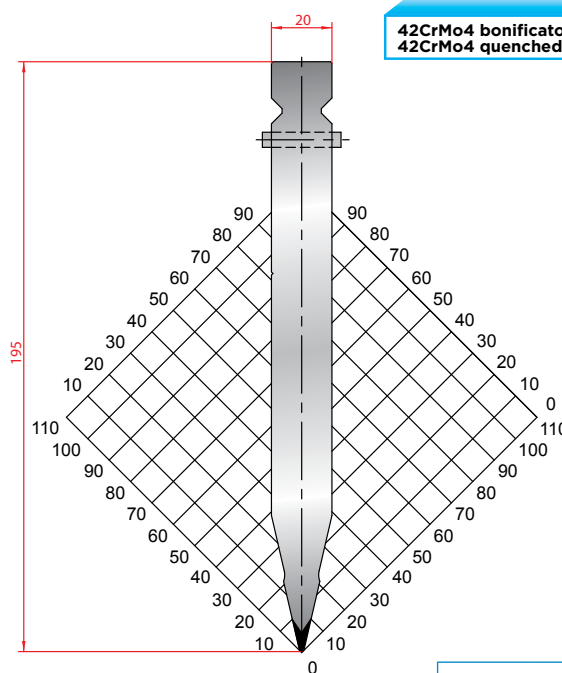

1316

$\alpha=26^\circ$  R=0,8 H=195.00 Max T/m=100

SAFE-KLIK / SAFETY BUTTONS

**8210**  
FRÉZOVÁNÍ OTVORU  
PRO SAFE-KLIK  
MILLING FOR SAFETY  
BUTTON

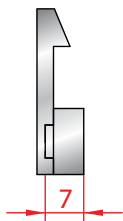

**8211**  
codici / codes  
-1237 -1240

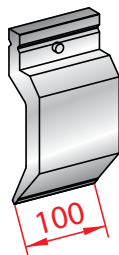

**8218**  
codici / codes  
-1238 -1249  
-1250 -1251- 1313

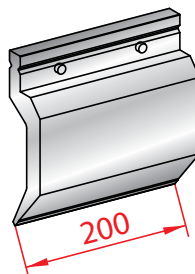
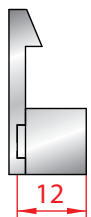

**8212**  
codici / codes  
-1234 -1235

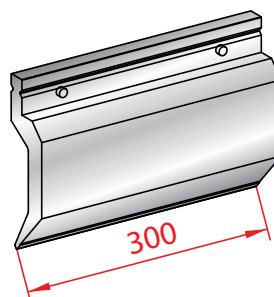
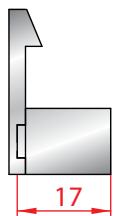

**8213**  
codici / codes  
-1295-1302  
-1303-1308-4361

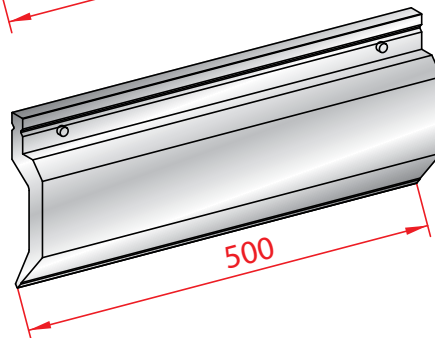
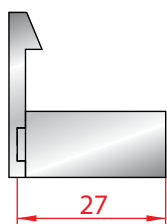

**8214**  
codici / codes  
- 1233-1314

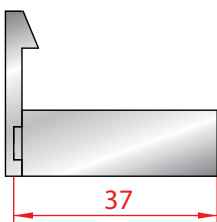

**8215**  
codici / code  
- 1236

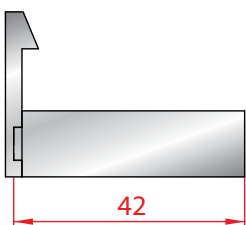

**8216**  
codici / code  
- 1294

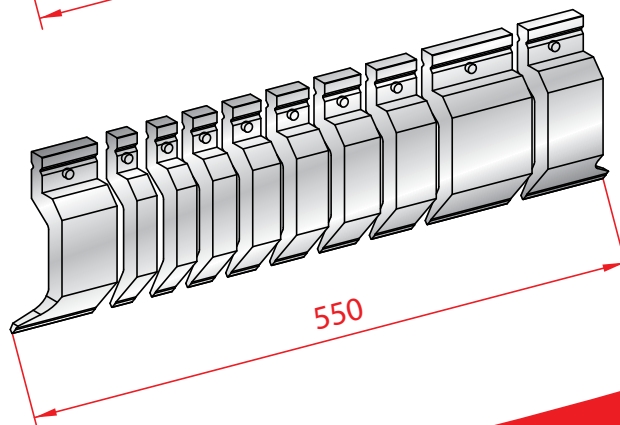
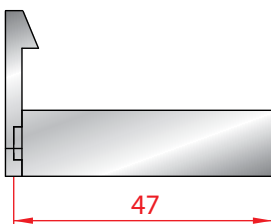

TRUMPF

## SAFE-KLIK / SAFETY BUTTONS



TRUMPF

RAZNÍKY / PUNCHES

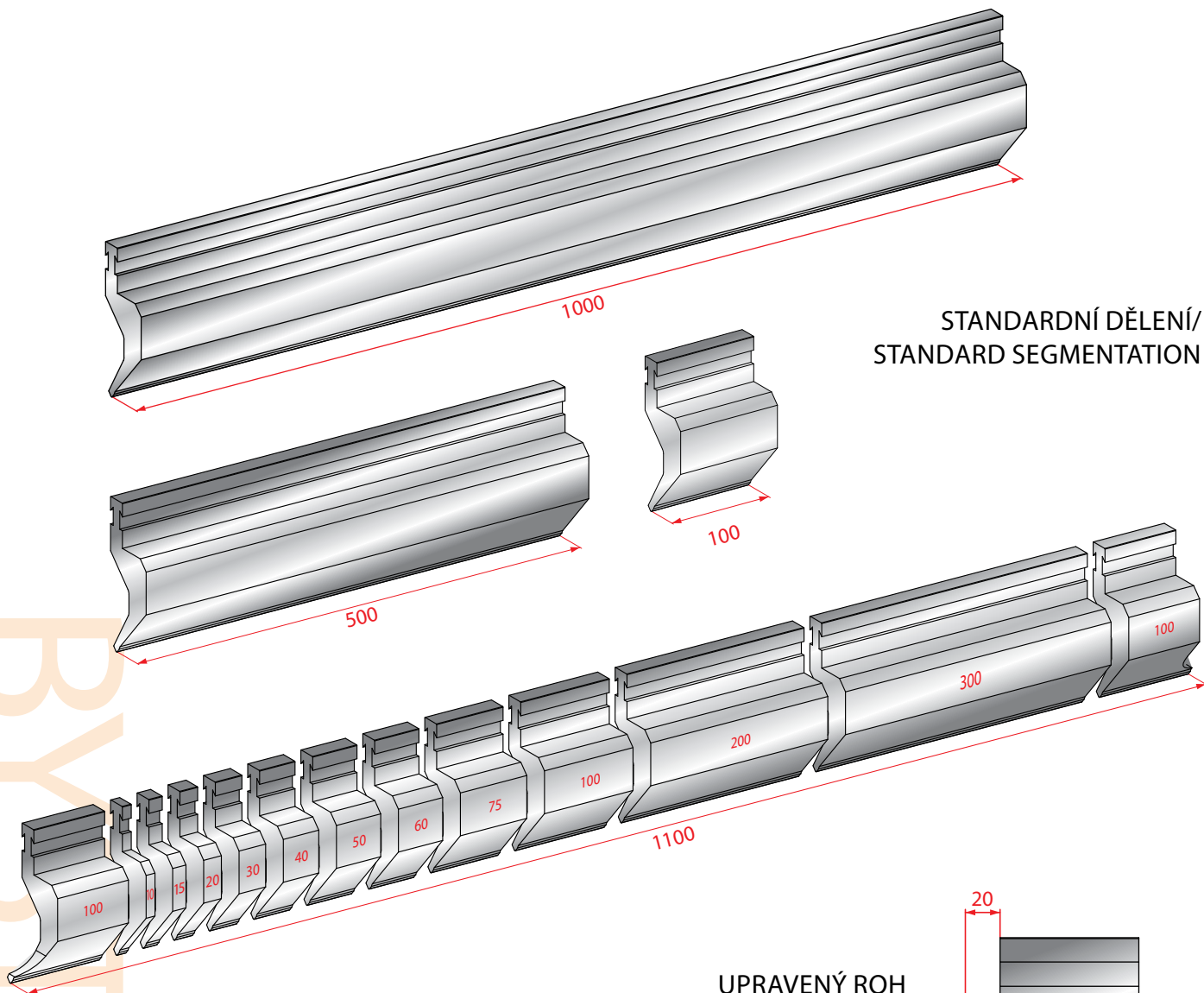

STANDARDNÍ DĚLENÍ/  
STANDARD SEGMENTATION

UPRAVENÝ ROH  
MILLED HORN

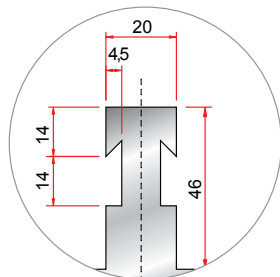
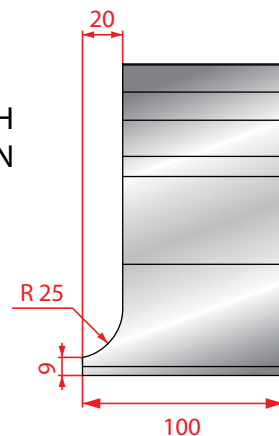

BYSTRONIC R  
strana / page 94

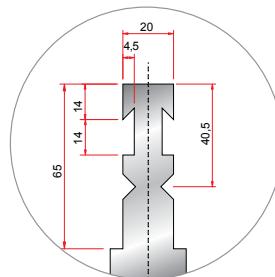

BYSTRONIC RF-A  
strana / page 97

BYSTRONIC

ÚPRAVY NA PŘÁNÍ / MODIFICATIONS ON REQUEST

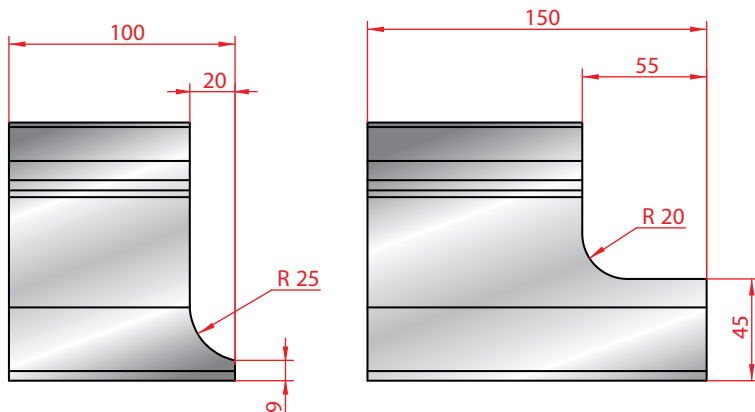

SPECIÁLNÍ ROHY /  
SPECIAL HORNS



SPECIÁLNÍ DĚLENÍ /  
SPECIAL SEGMENTATION

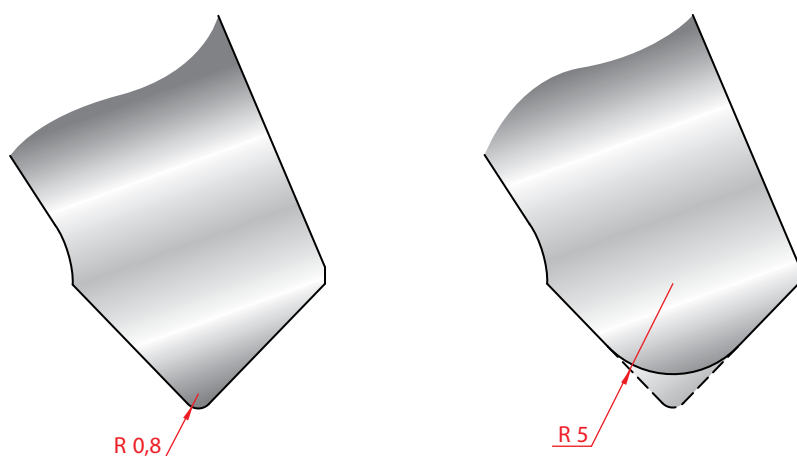

ÚPRAVA RÁDIUSU /  
RADIUS MODIFICATION

BYSTRONIC



RAZNÍKY - 86° / PUNCHES - 86°

42CrMo4 bonificato  
42CrMo4 quenched

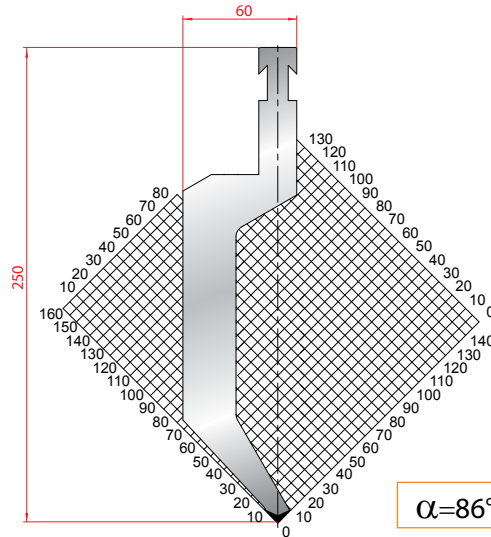

TYP UPNUTÍ RF-A  
V CENĚ RAZNÍKU  
RF-A TANG INCLUDED  
ON DEMAND

1298

$\alpha=86^\circ$  R=1.5 H=250.00 Max T/m=60

RAZNÍKY - 85° / PUNCHES - 85°

42CrMo4 bonificato  
42CrMo4 quenched

NOVINKA  
new

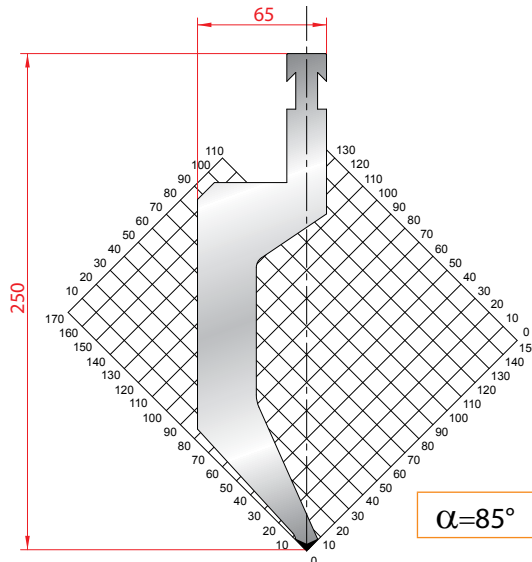

TYP UPNUTÍ RF-A  
V CENĚ RAZNÍKU  
RF-A TANG INCLUDED  
ON DEMAND

1321

$\alpha=85^\circ$  R=1.5 H=250.00 Max T/m=100

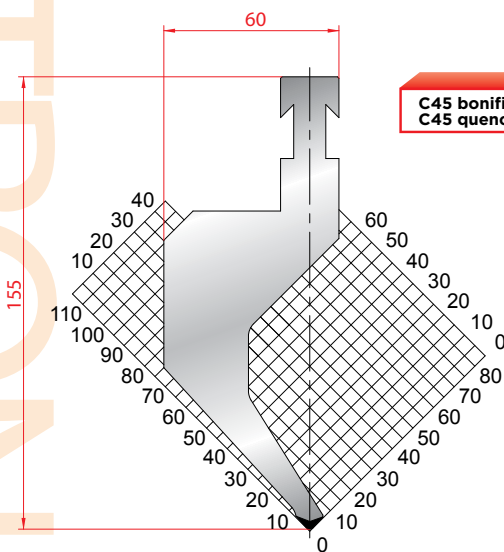

C45 bonificato  
C45 quenched

1216

$\alpha=85^\circ$  R=1.5 H=155.00 Max T/m=50

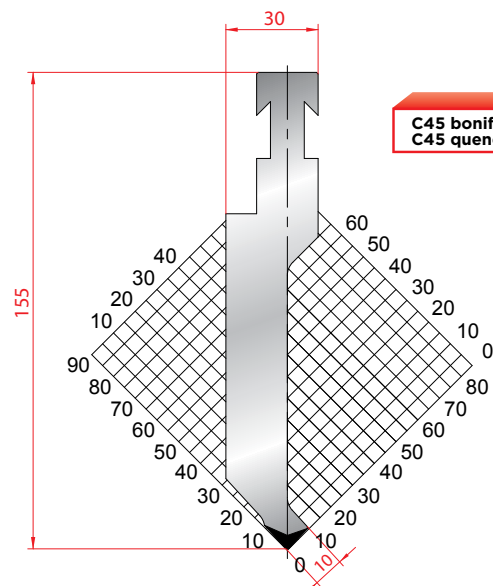

C45 bonificato  
C45 quenched

1218

$\alpha=85^\circ$  R=1 H=155.00 Max T/m=100

RAZNÍKY - 30° / PUNCHES - 30°

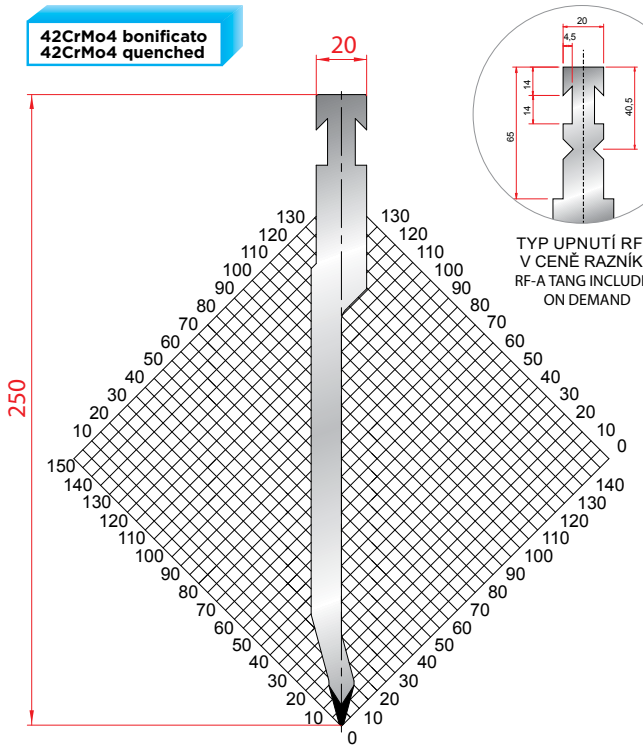

1299

$\alpha=30^\circ$  R=1 H=250.00 Max T/m=80

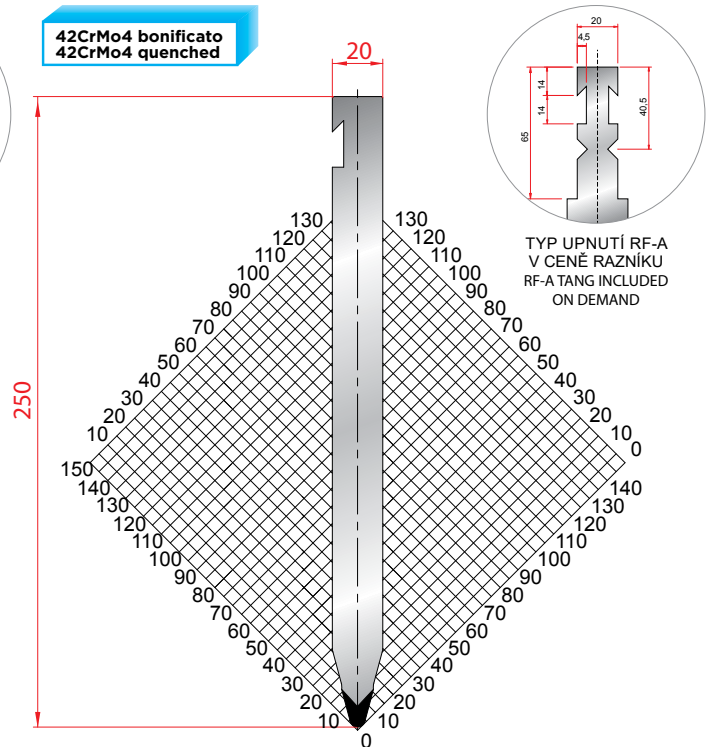

1300

$\alpha=30^\circ$  R=3 H=250.00 Max T/m=120

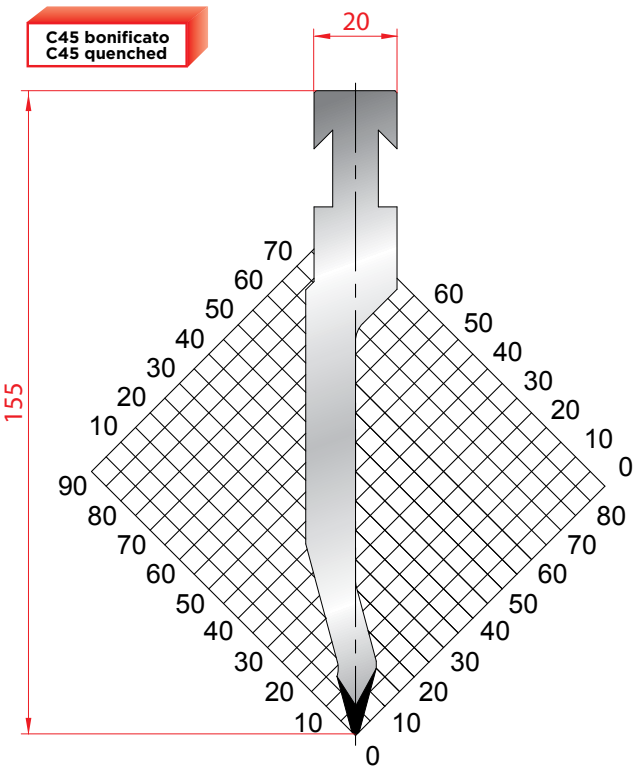

1220

$\alpha=30^\circ$  R=1 H=155.00 Max T/m=80

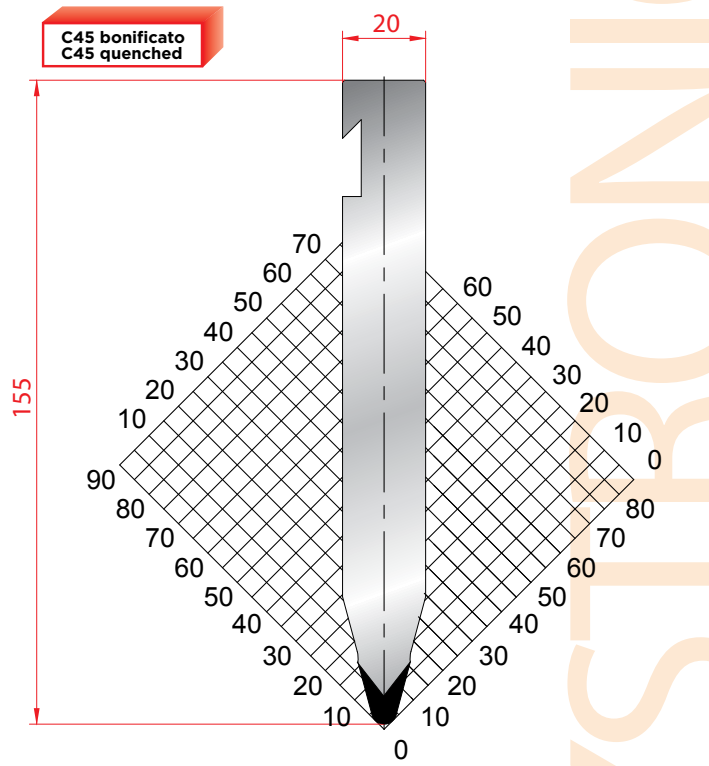

1255

$\alpha=30^\circ$  R=3 H=155.00 Max T/m=100

RAZNÍKY - 30° / PUNCHES - 30°

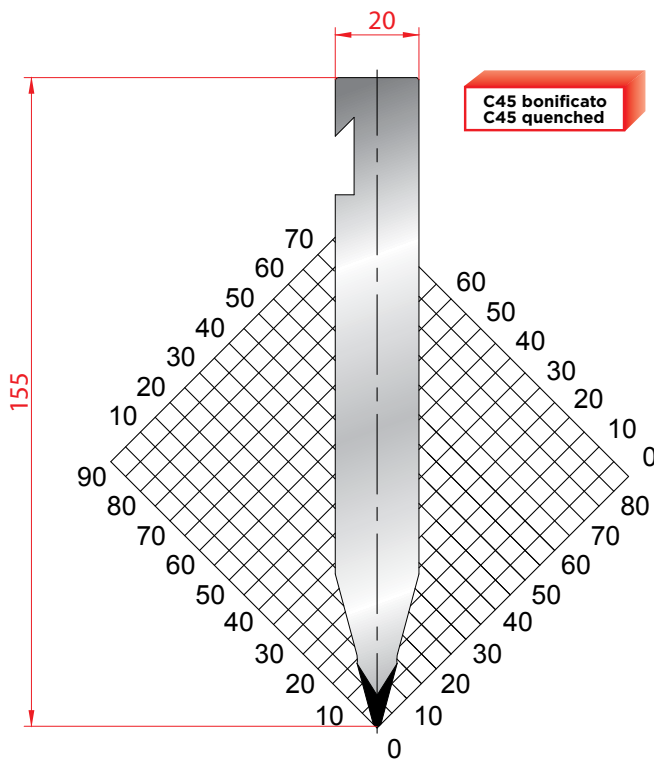

1226

$\alpha=30^\circ$  R=1 H=155.00 Max T/m=100

RAZNÍKY - 28° / PUNCHES - 28°

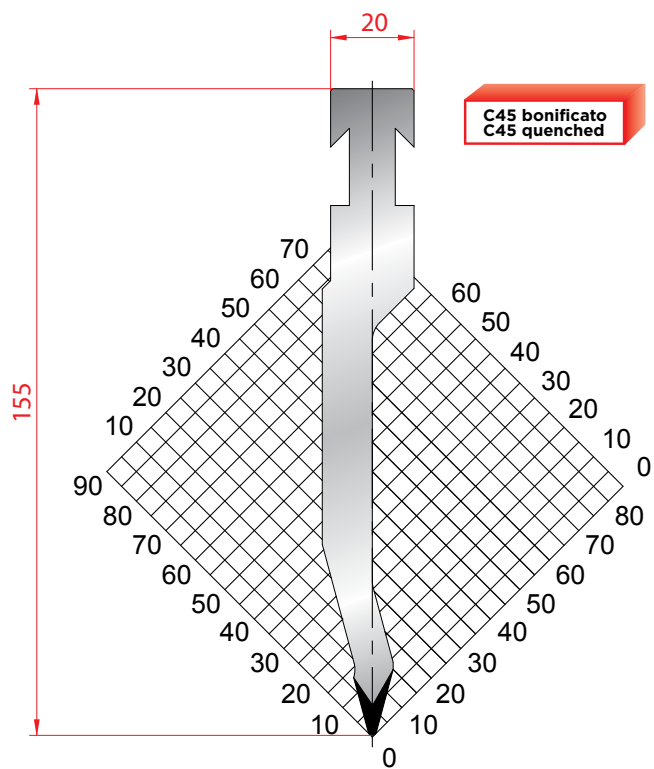

1221

$\alpha=28^\circ$  R=1 H=155.00 Max T/m=80

BYSTRONIC

RAZNÍKY - 88° / PUNCHES - 88°

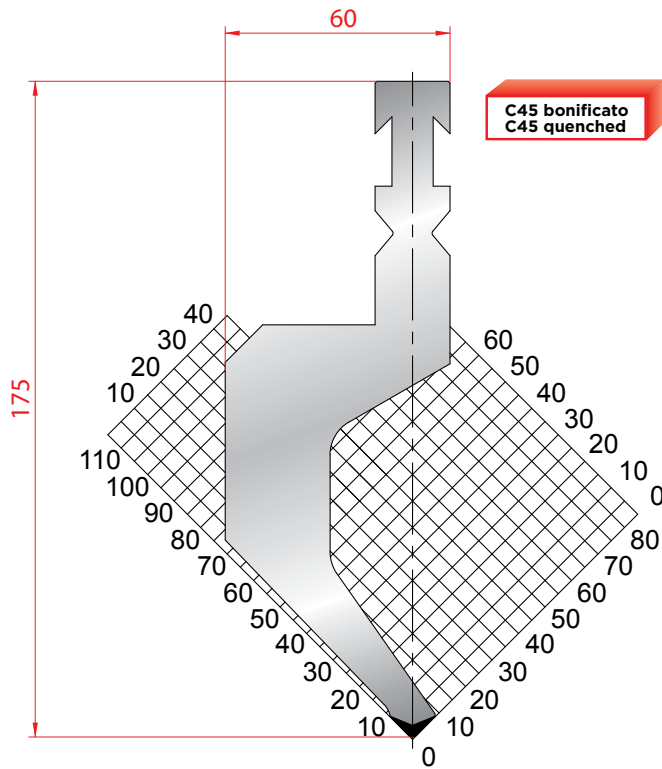

1227

$\alpha=88^\circ$  R=1.5 H=175.00 Max T/m=50

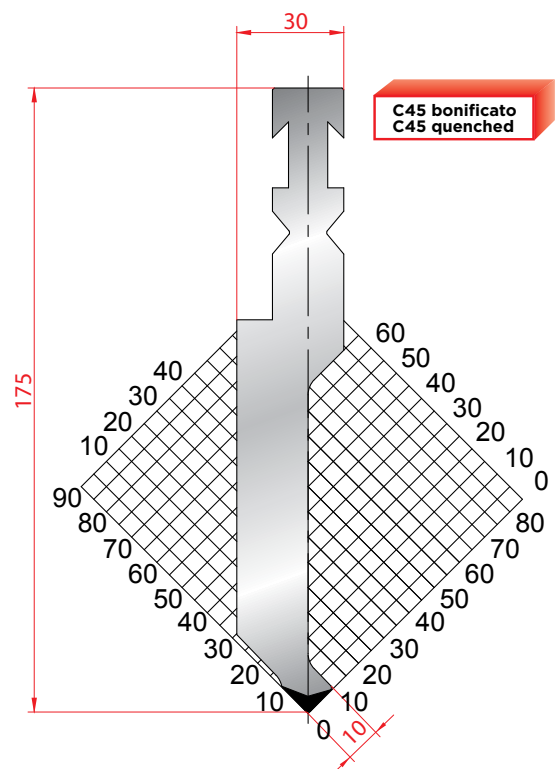

1229

$\alpha=88^\circ$  R=1 H=175.00 Max T/m=100

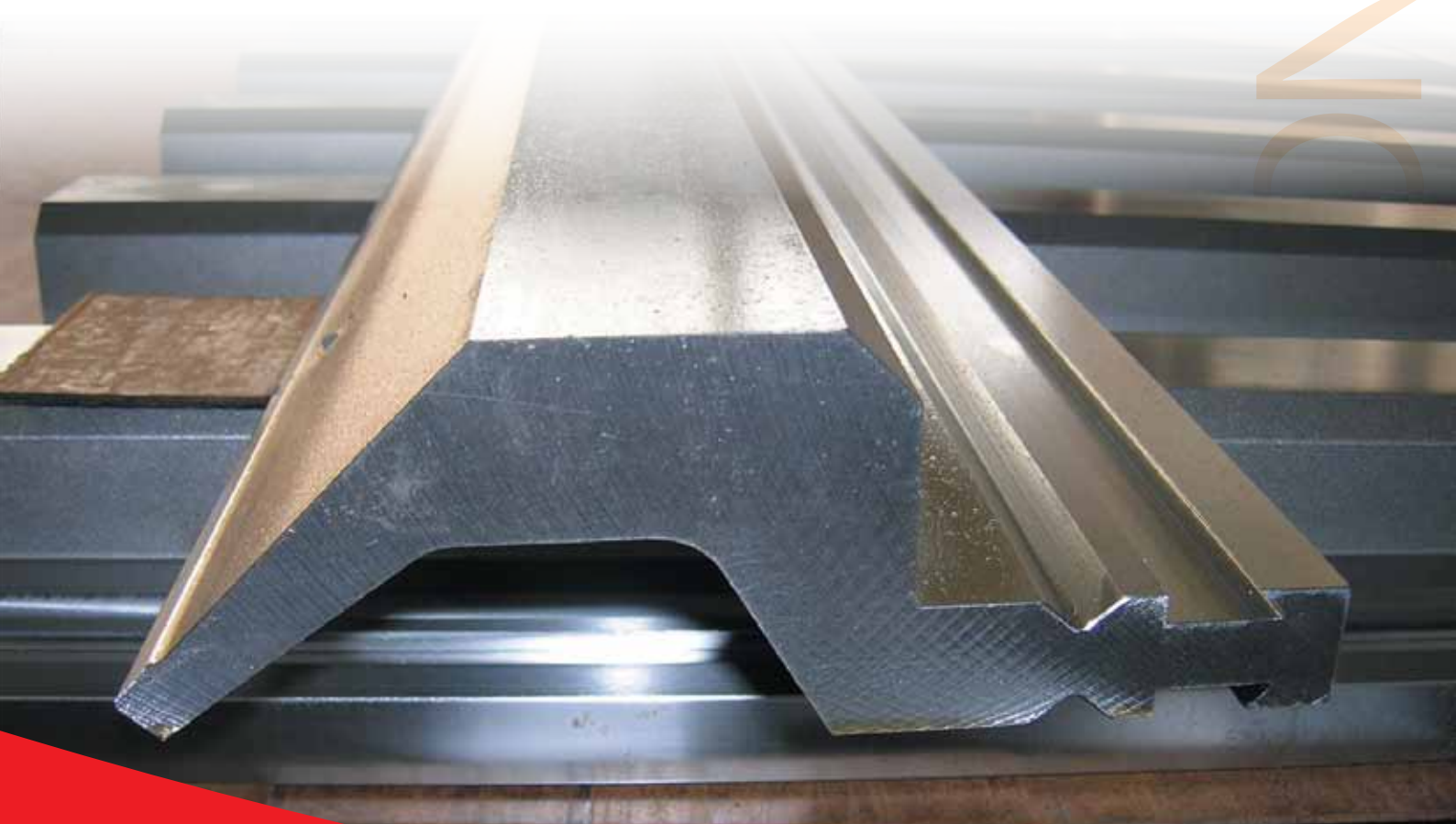

BYSTRONIC

RAZNÍKY - 30° / PUNCHES - 30°

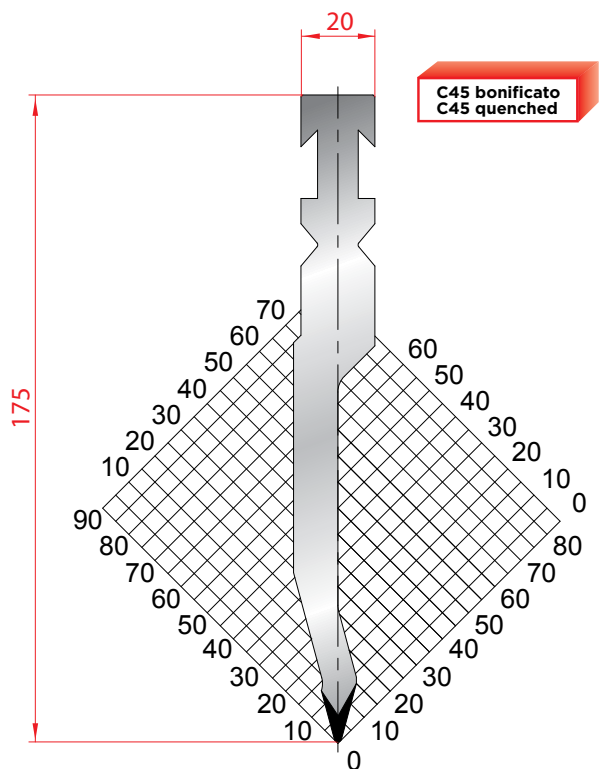

1230

$\alpha=30^\circ$  R=1 H=175.00 Max T/m=80

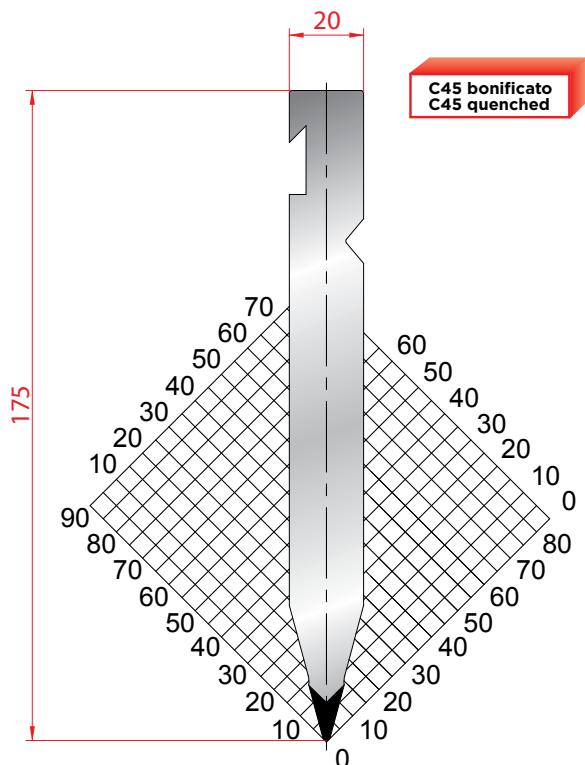

1232

$\alpha=30^\circ$  R=1 H=175.00 Max T/m=100

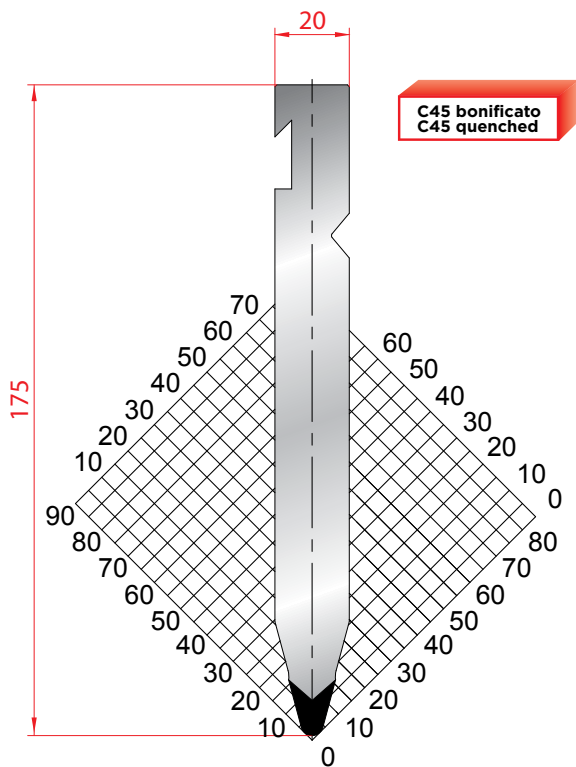

1231

$\alpha=30^\circ$  R=3 H=175.00 Max T/m=100

BYSTRONIC