

MATRICE / DIES

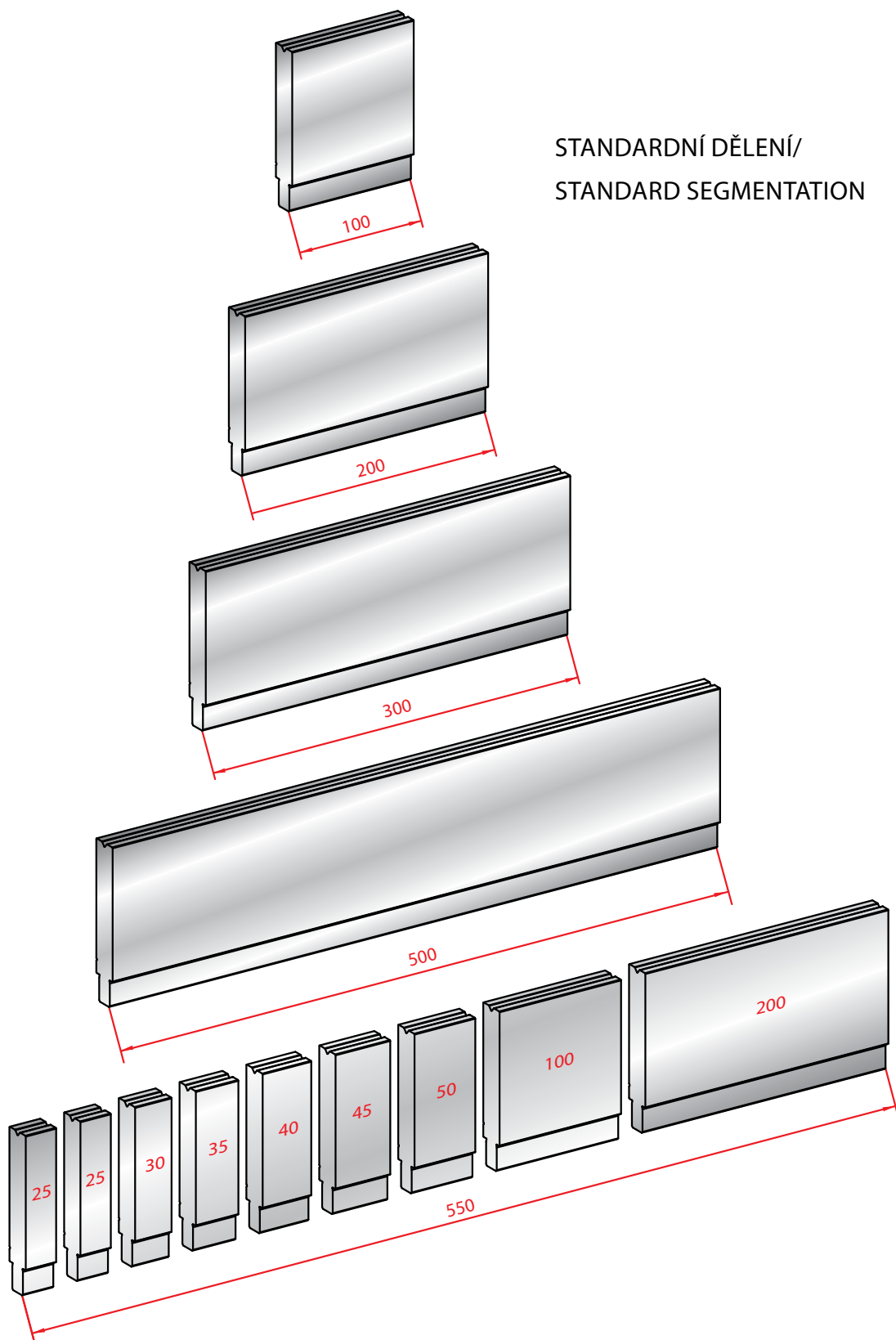

TRUMPF

ÚPRAVY NA PŘÁNÍ / MODIFICATIONS ON REQUEST

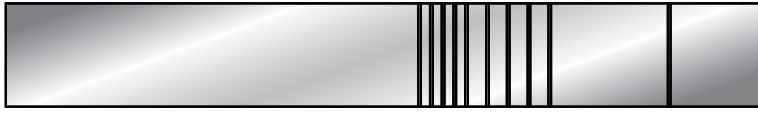

SPECIÁLNÍ DĚLENÍ /
SPECIAL SEGMENTATION

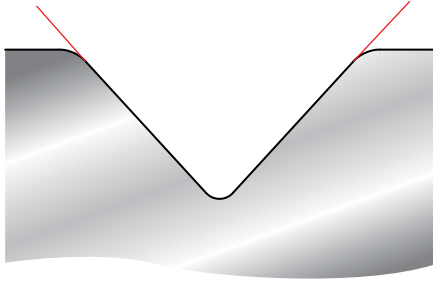

ÚPRAVA ÚHLU /
ANGLES MODIFICATION

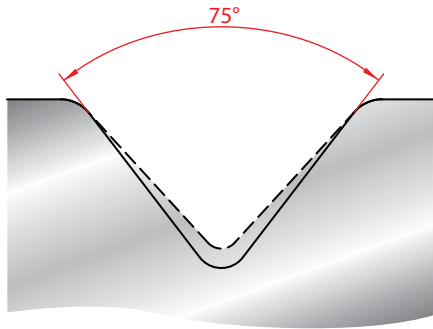

ÚPRAVA RÁDIUSU /
RADIUS MODIFICATION

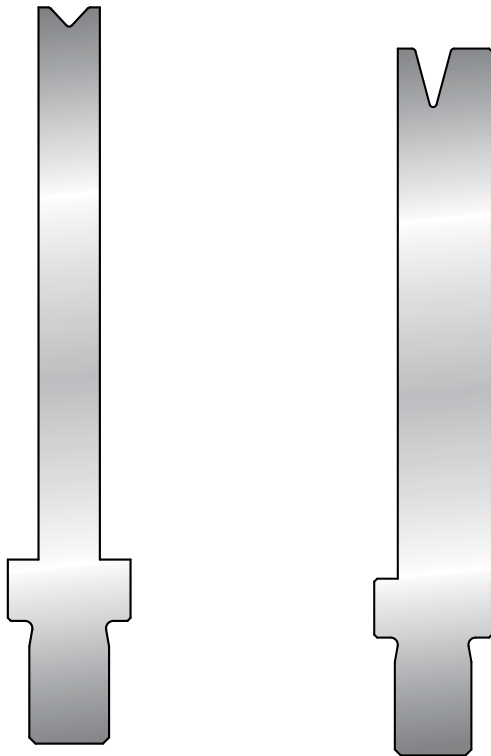

ZŮŽENÍ MATRIC
NA POPTÁVKU /
THIN BODY
ON REQUEST

TRUMPF

MATRICE / DIES

PRO MATRICE / FOR DIES:
3135 - 3222 - 3223 - 3224

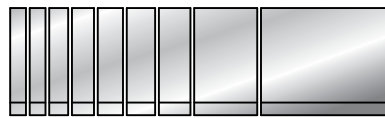

550

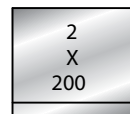
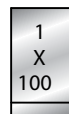

1050

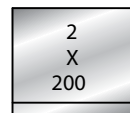
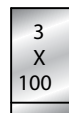
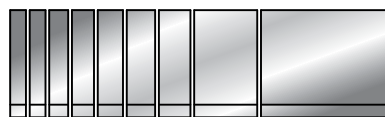

1250

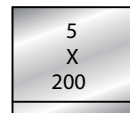
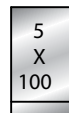

2050

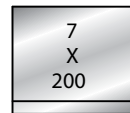
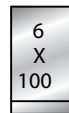

2550

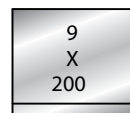
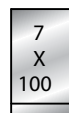
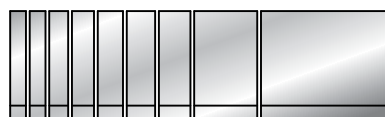

3050

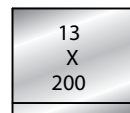
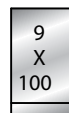











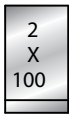
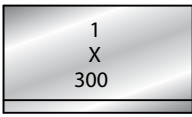

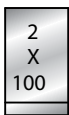
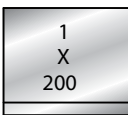
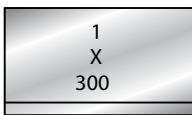
4050

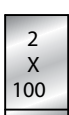
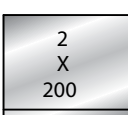
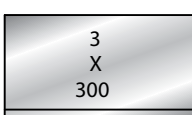
TRUMPF

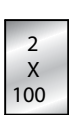
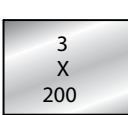
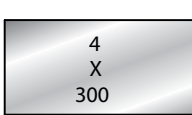
MATRICE / DIES

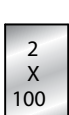
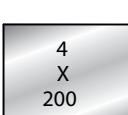
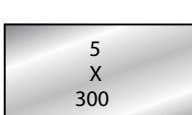
PRO MATRICE / FOR DIES:
3218 - 3219 - 3220 - 3221 - 3132 - 3133 - 3134

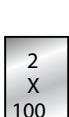
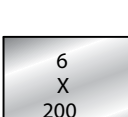
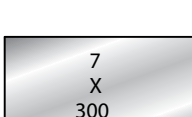
					550
					1050
					1250
					2050
					2550
					3050
					4050

TRUMPF

MATRICE / DIES

PRO VŠECHNY OSTATNÍ TYPY MATRIC
FOR ALL OTHERS TYPE OF DIES



550

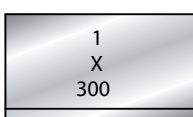
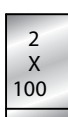

1050

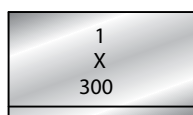
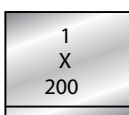
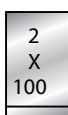

1250

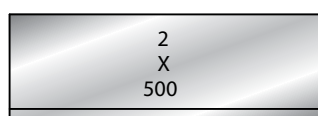
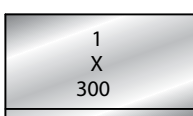
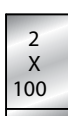

2050

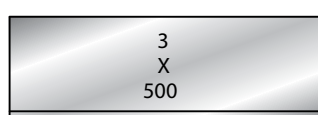
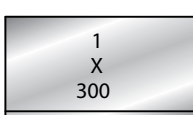
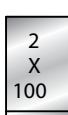

2550

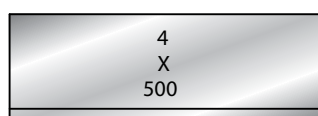
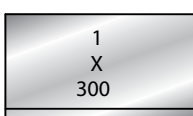
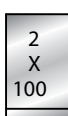

3050

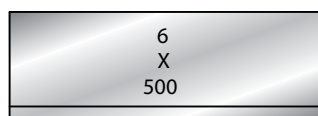
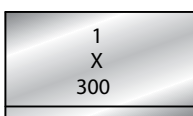
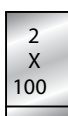

4050

TRUMPF

MATRICE 1V H100 - 86° / 1V DIES H100 - 86°

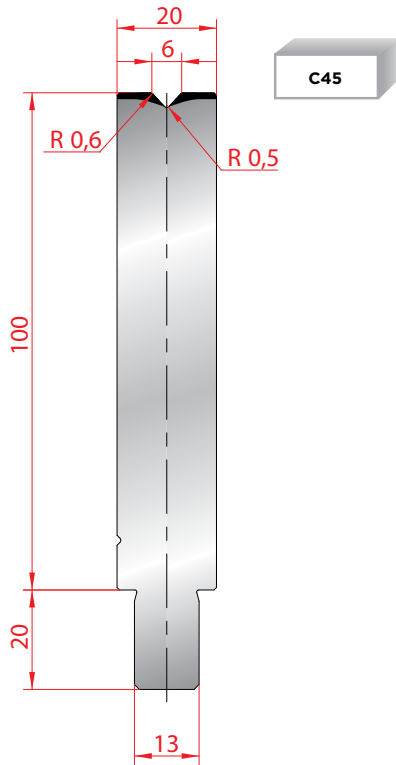

3123

Max T/m=100

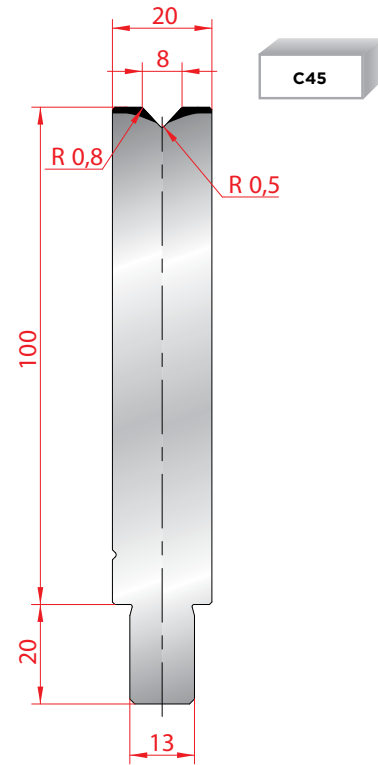

3124

Max T/m=100

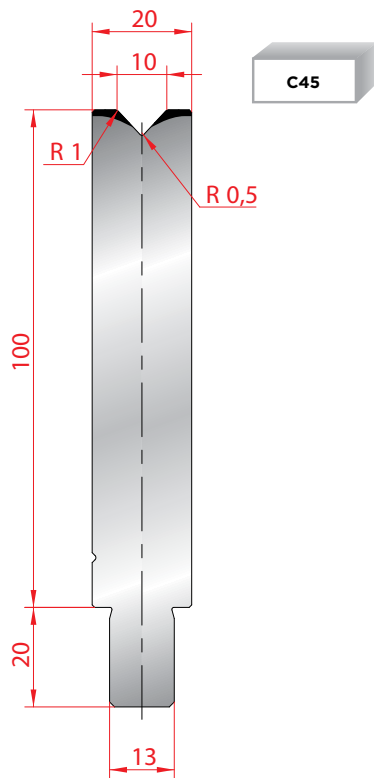

3125

Max T/m=100

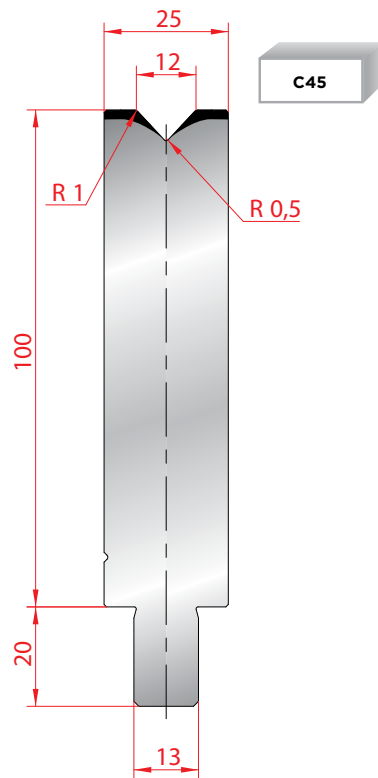

3126

Max T/m=100

TRUMPF

MATRICE 1V H100 - 86° / 1V DIES H100 - 86°

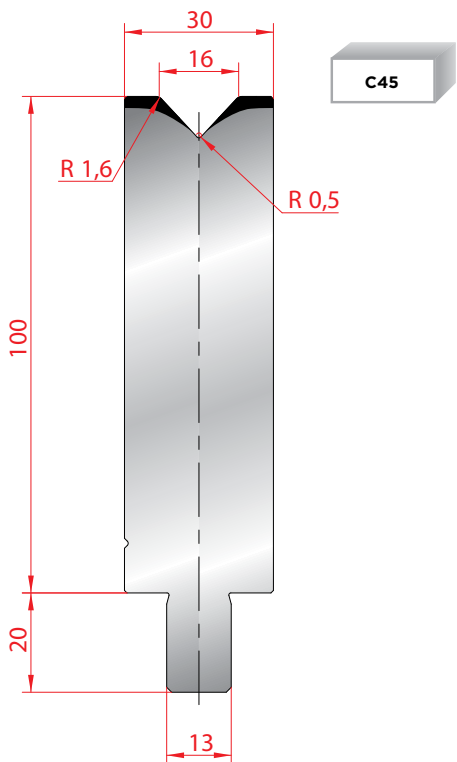

3127

Max T/m=100

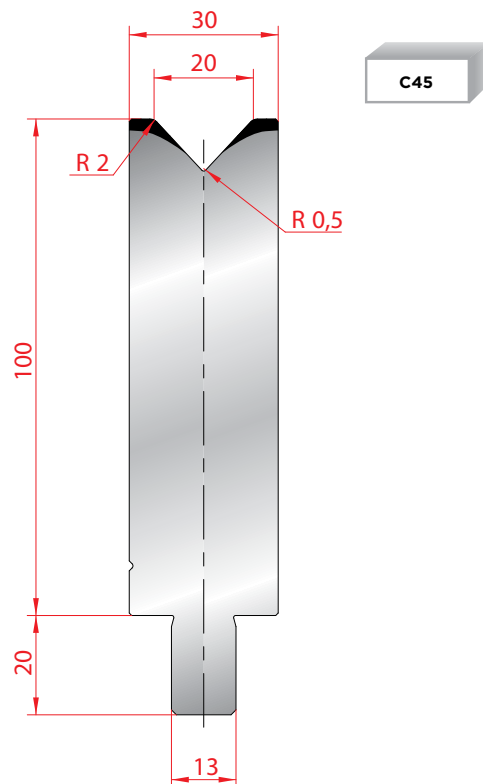

3128

Max T/m=100

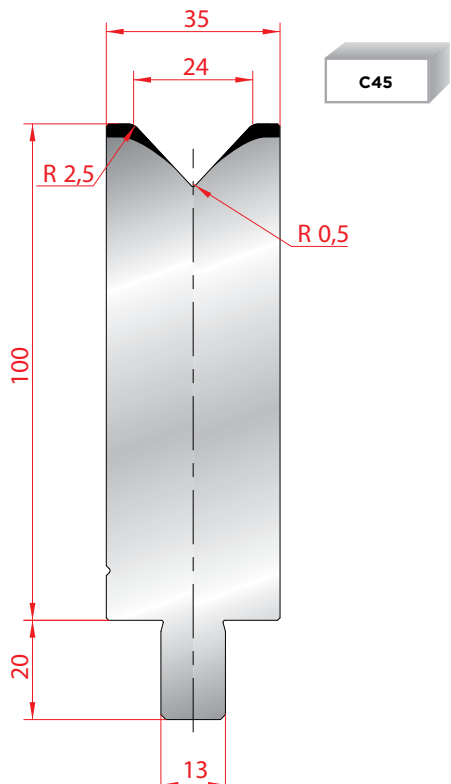

3129

Max T/m=100

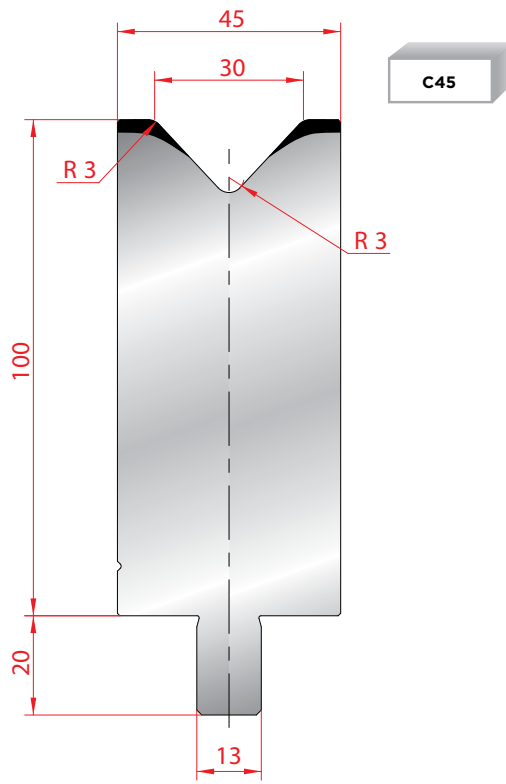

3130

Max T/m=100

TRUMPF

MATRICE 1V H100 - 86° / 1V DIES H100 - 86°

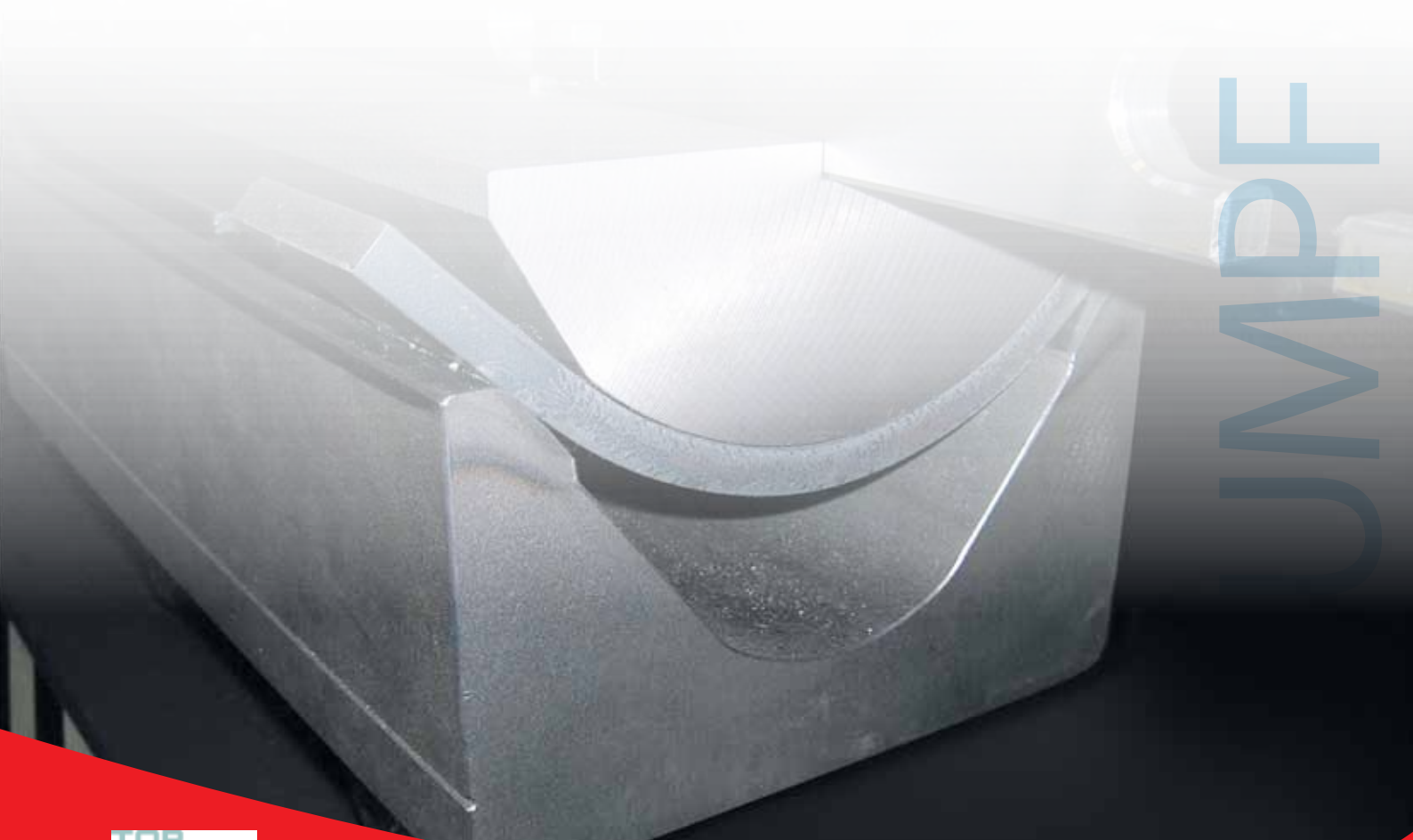
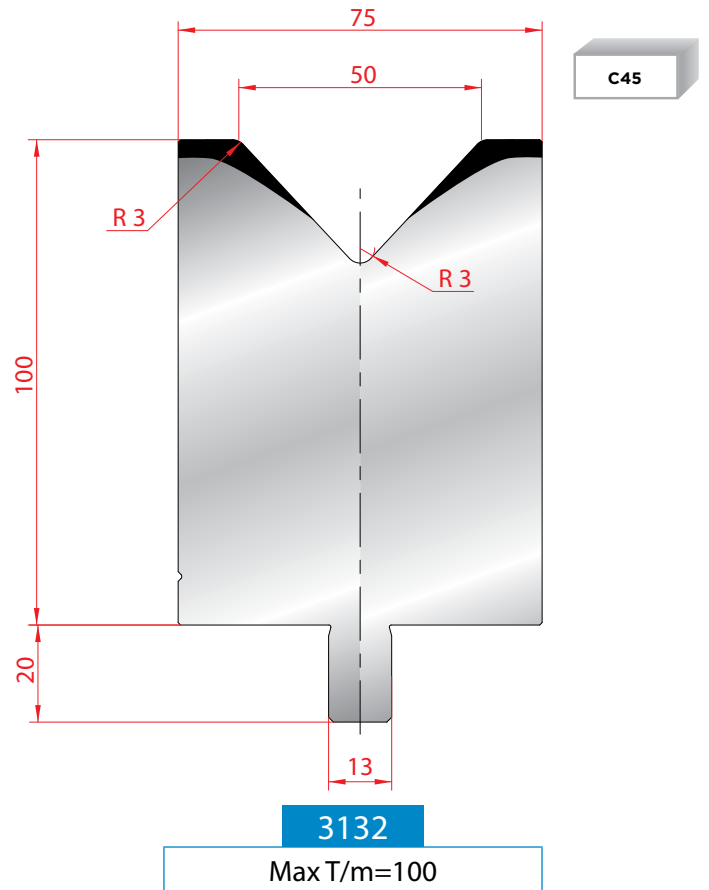
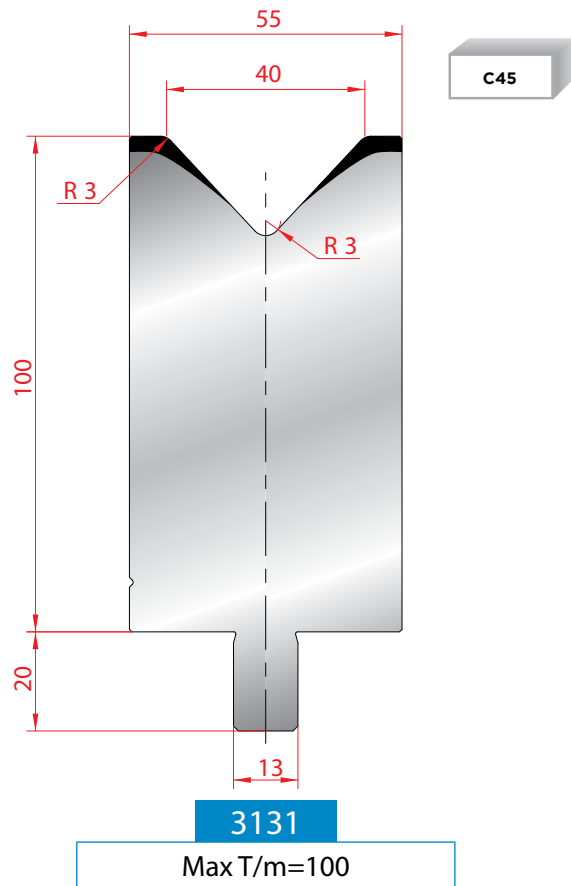

JWMPF

MATRICE 1V H100 - 80° / 1V DIES H100 - 80°

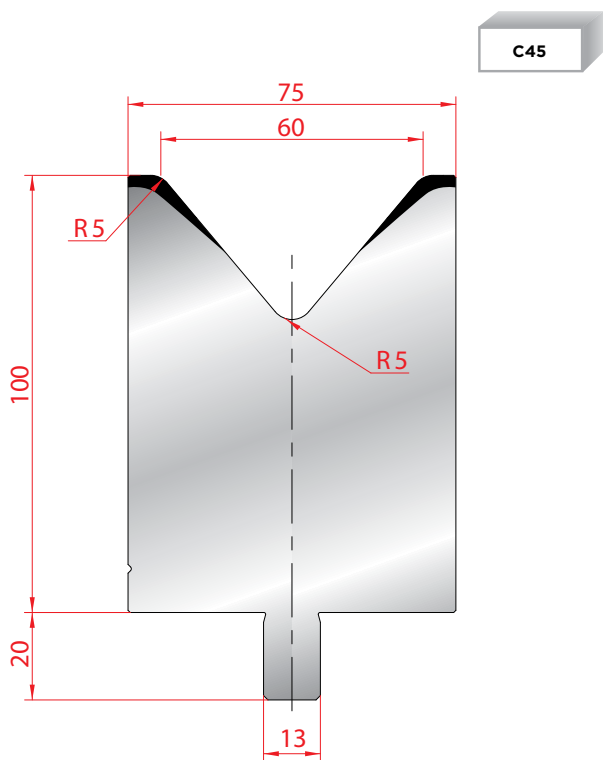

3133

Max T/m=100

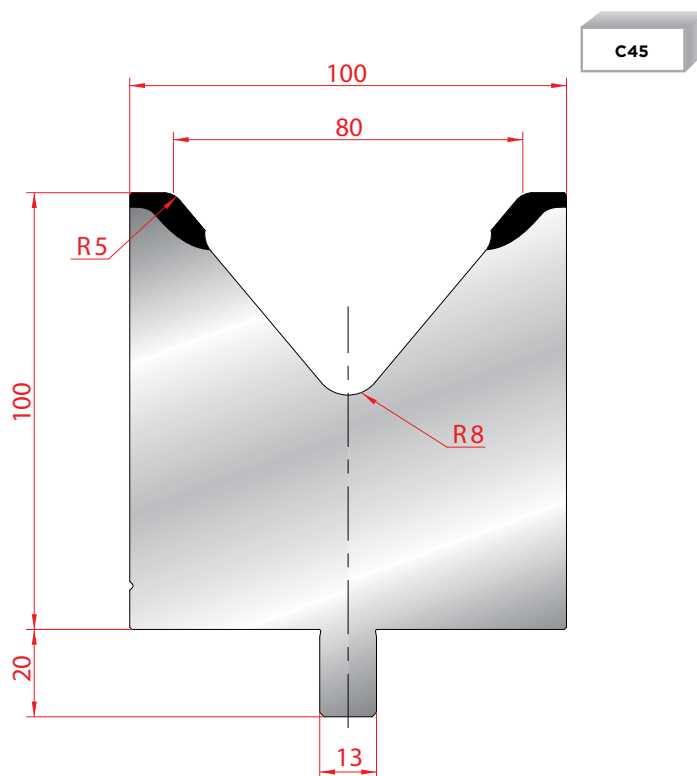

3134

Max T/m=100

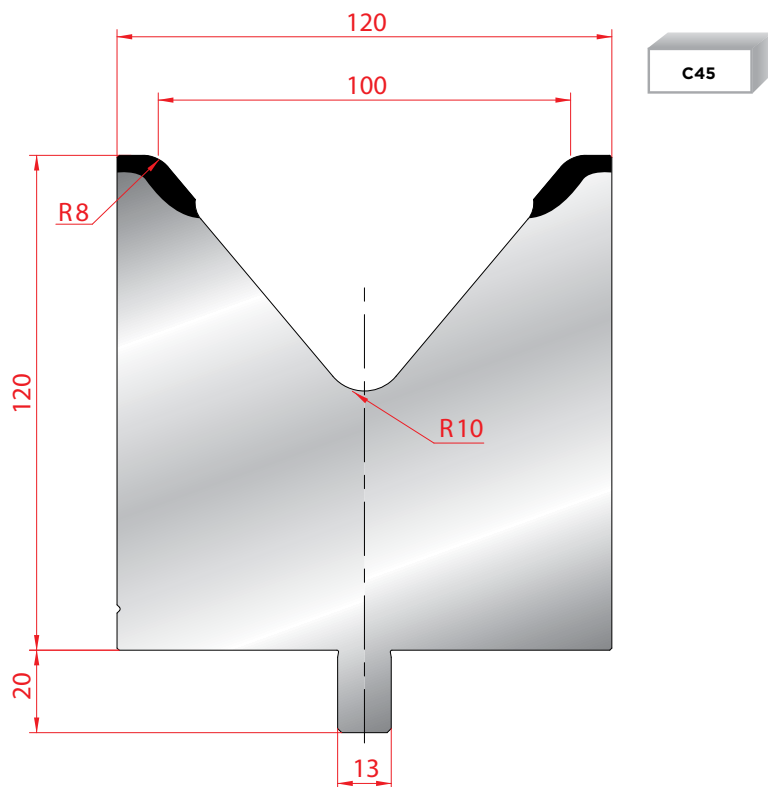

3135

Max T/m=100

TRUMPF

MATRICE 1V H100 - 30° / 1V DIES H100 - 30°

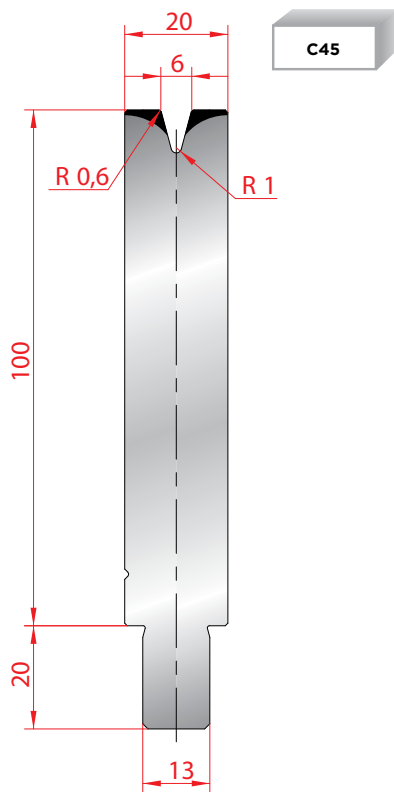

3136

Max T/m=50

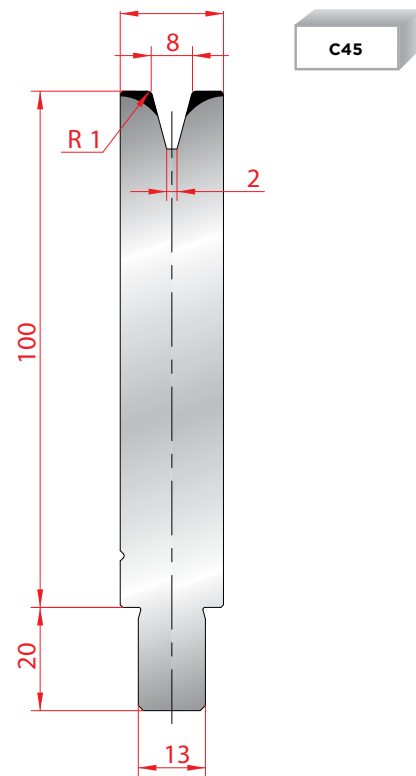

3137

Max T/m=40

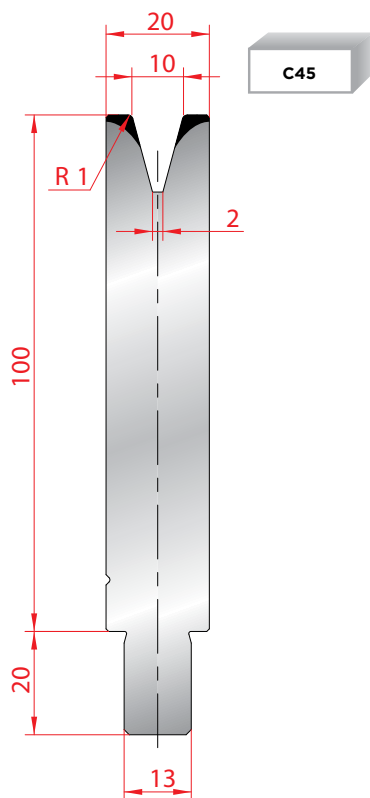

3138

Max T/m=40

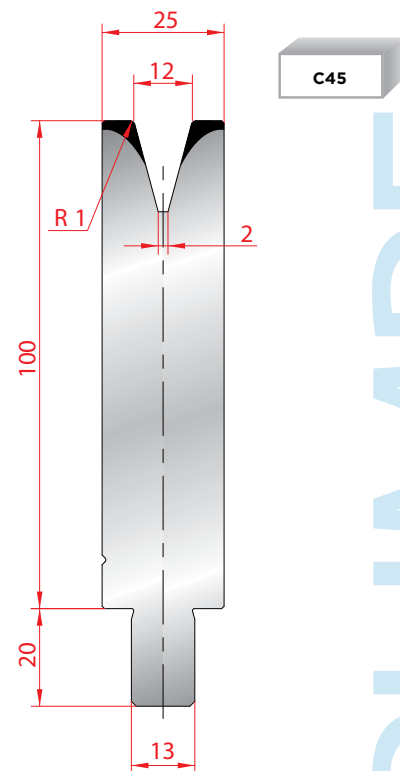

3139

Max T/m=50

TRUMPF

MATRICE 1V H100 - 30° / 1V DIES H100 - 30°

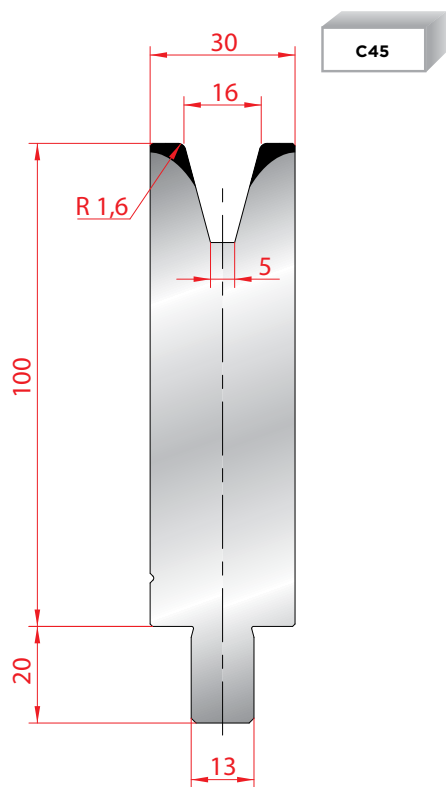

3140

Max T/m=45

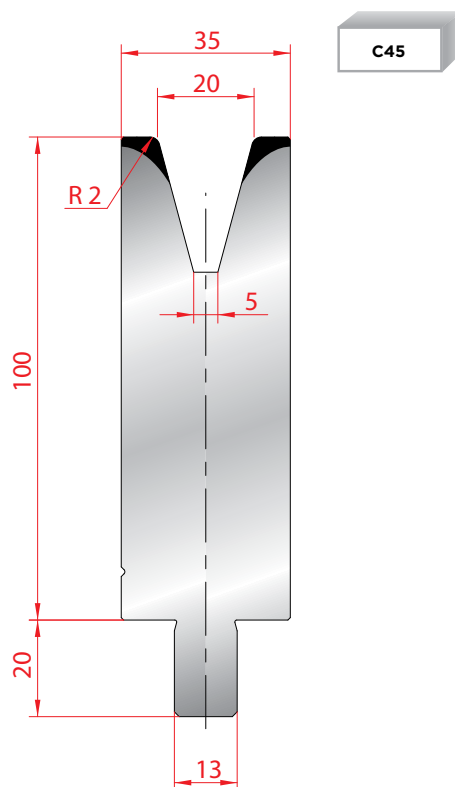

3141

Max T/m=50

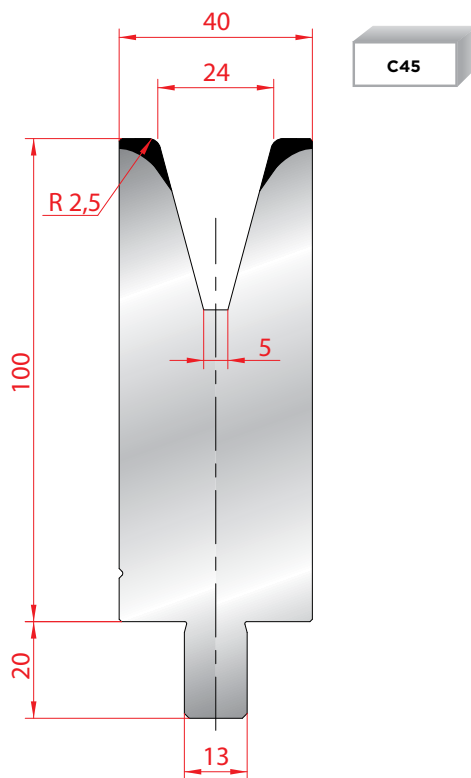

3142

Max T/m=50

TRUMPF

MATRICE 1V H100 - 86° / 1V DIES H100 - 86°

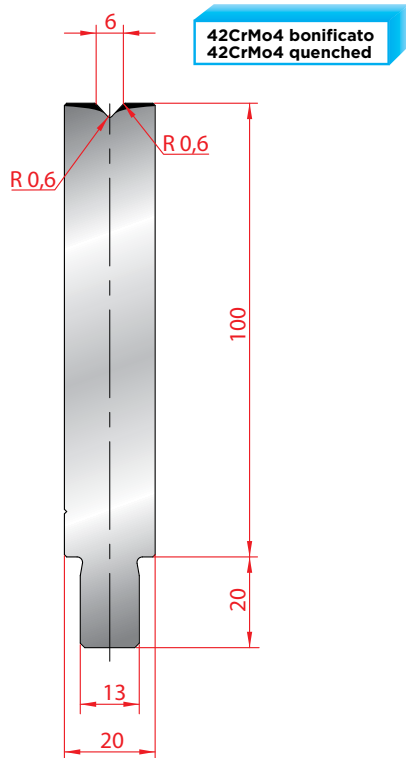

3200

Max T/m=100

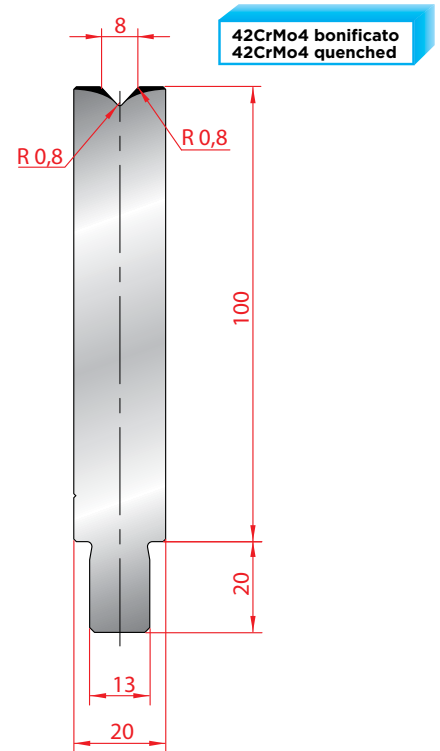

3201

Max T/m=100

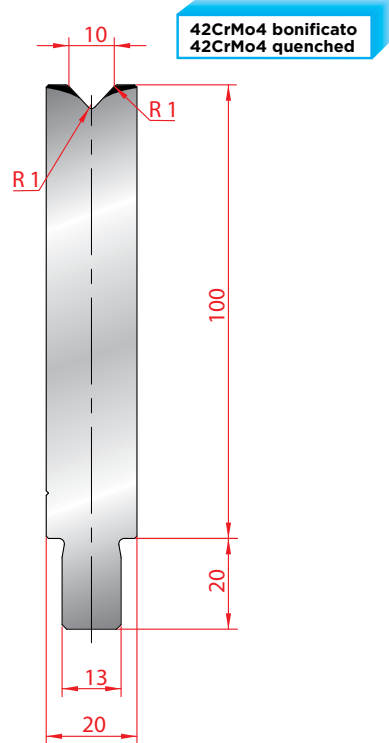

3202

Max T/m=100

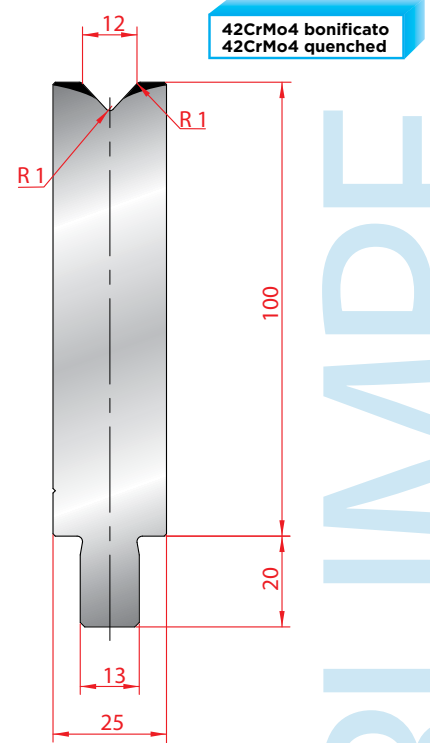

3203

Max T/m=100

TRUMPF

MATRICE 1V H100 - 86° / 1V DIES H100 - 86°

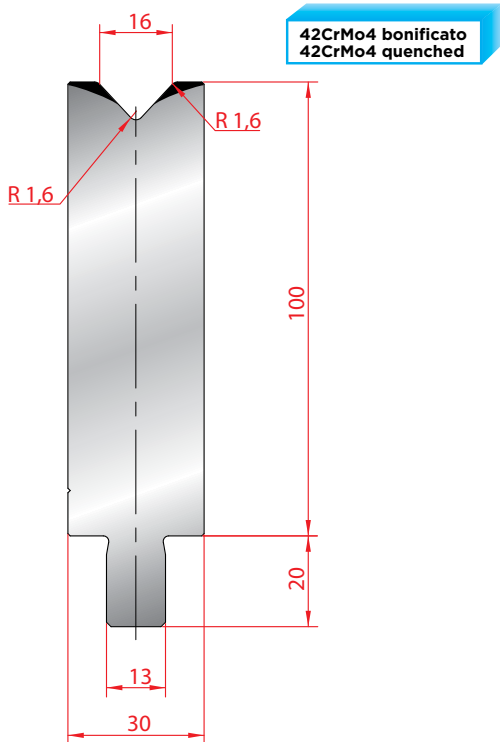

3204

Max T/m=100

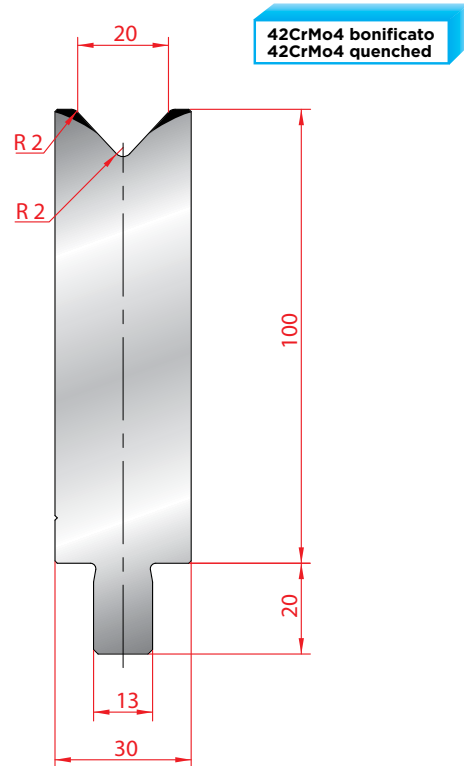

3205

Max T/m=100

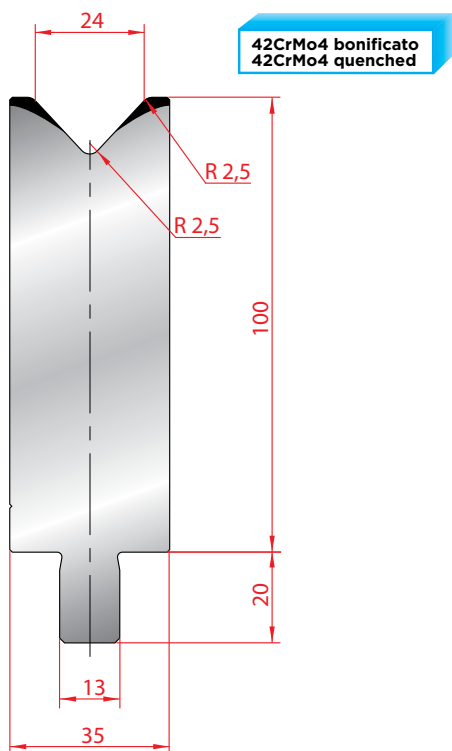

3215

Max T/m=100

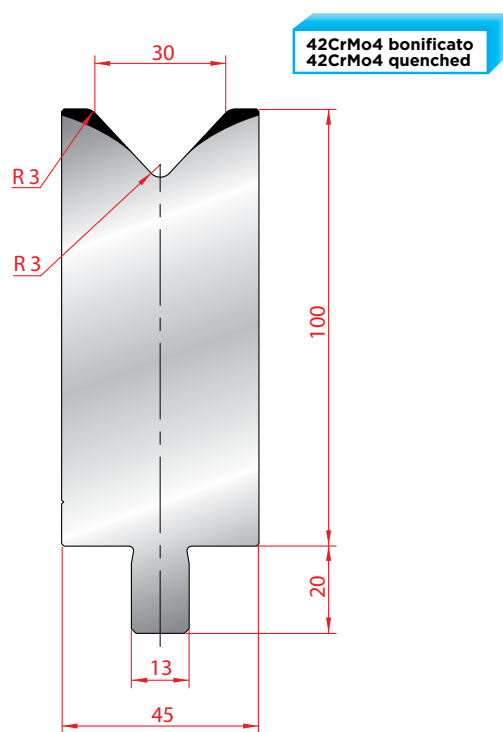

3216

Max T/m=100

TRUMPF

MATRICE 1V H100 - 86° / 1V DIES H100 - 86°

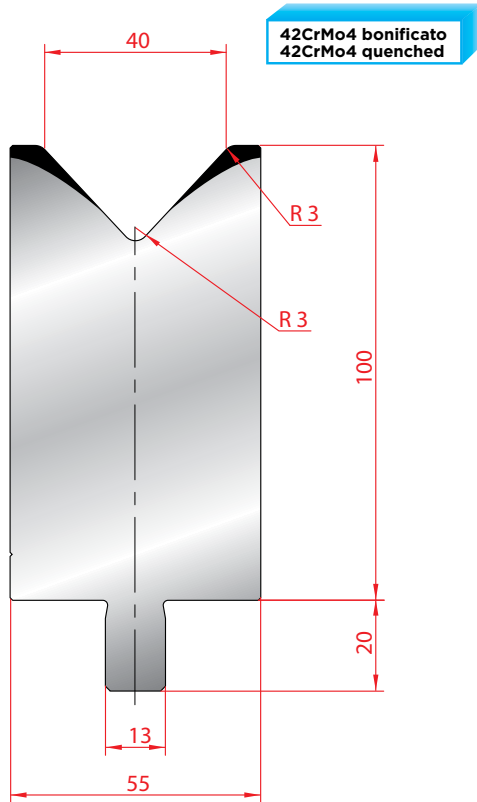

3217

Max T/m=120

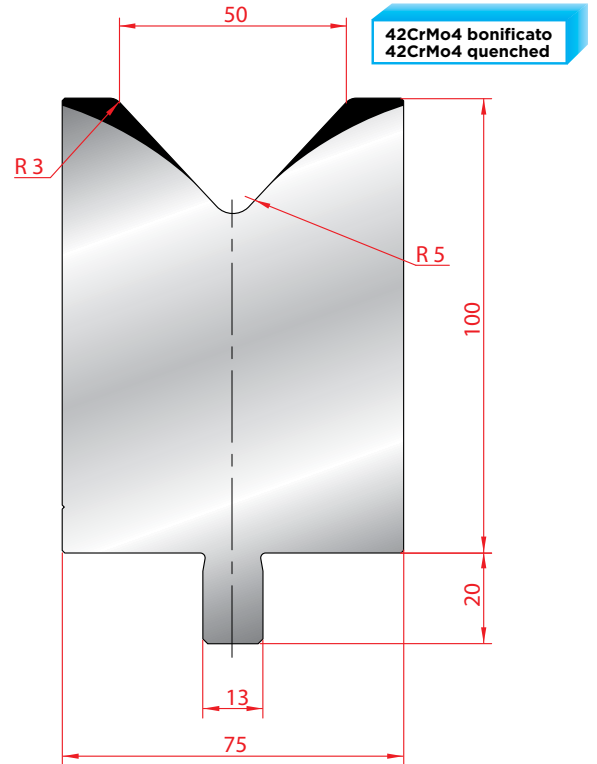

3218

Max T/m=150



TRUMPF

MATRICE 1V H100 - 84° / 1V DIES H100 - 84°

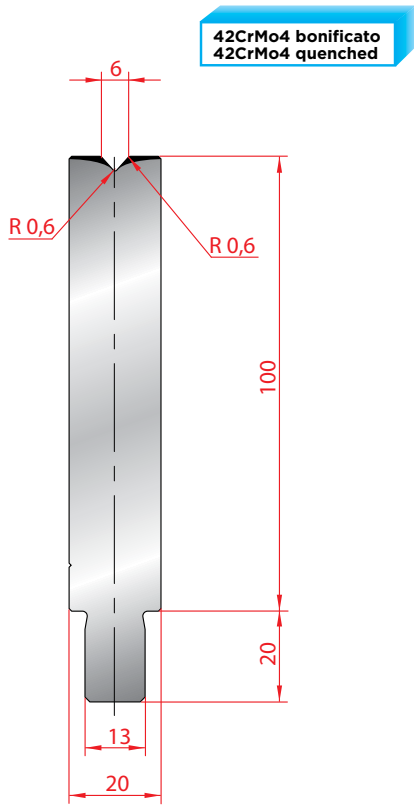

3225

Max T/m=130

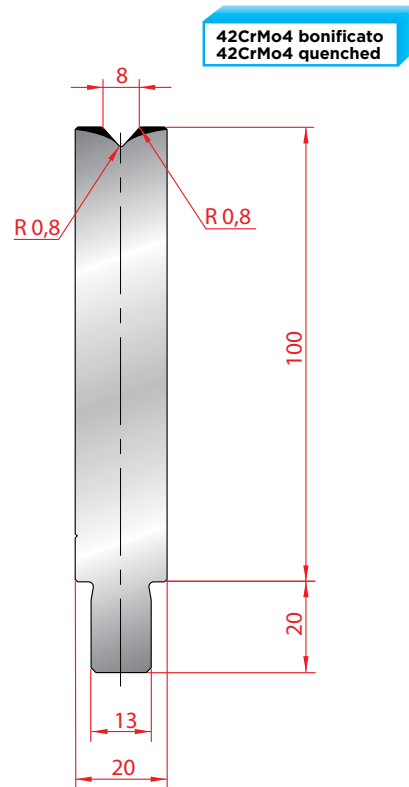

3226

Max T/m=100

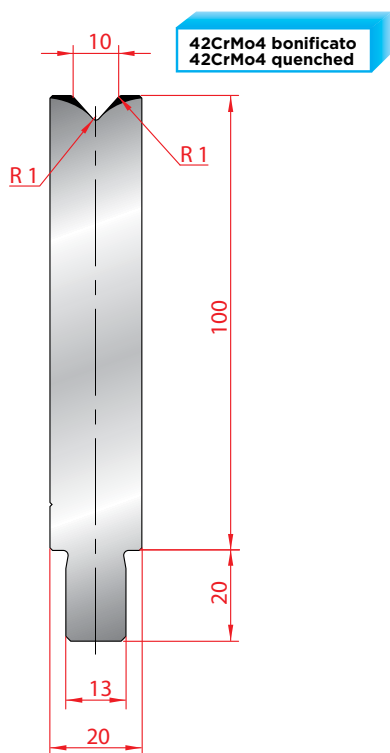

3227

Max T/m=100

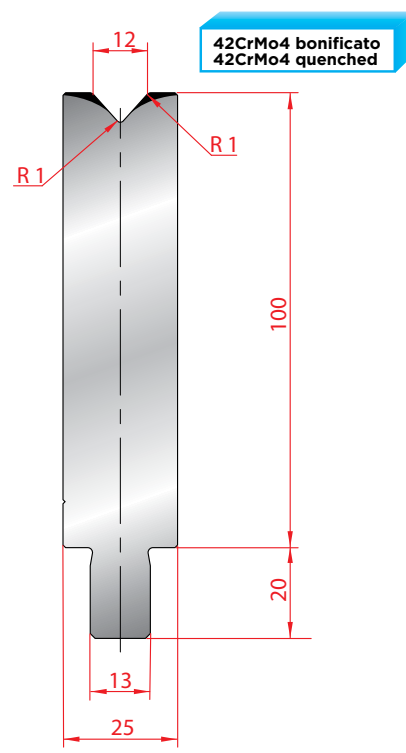

3228

Max T/m=100

TRUMPF

MATRICE 1V H100 - 84° / 1V DIES H100 - 84°

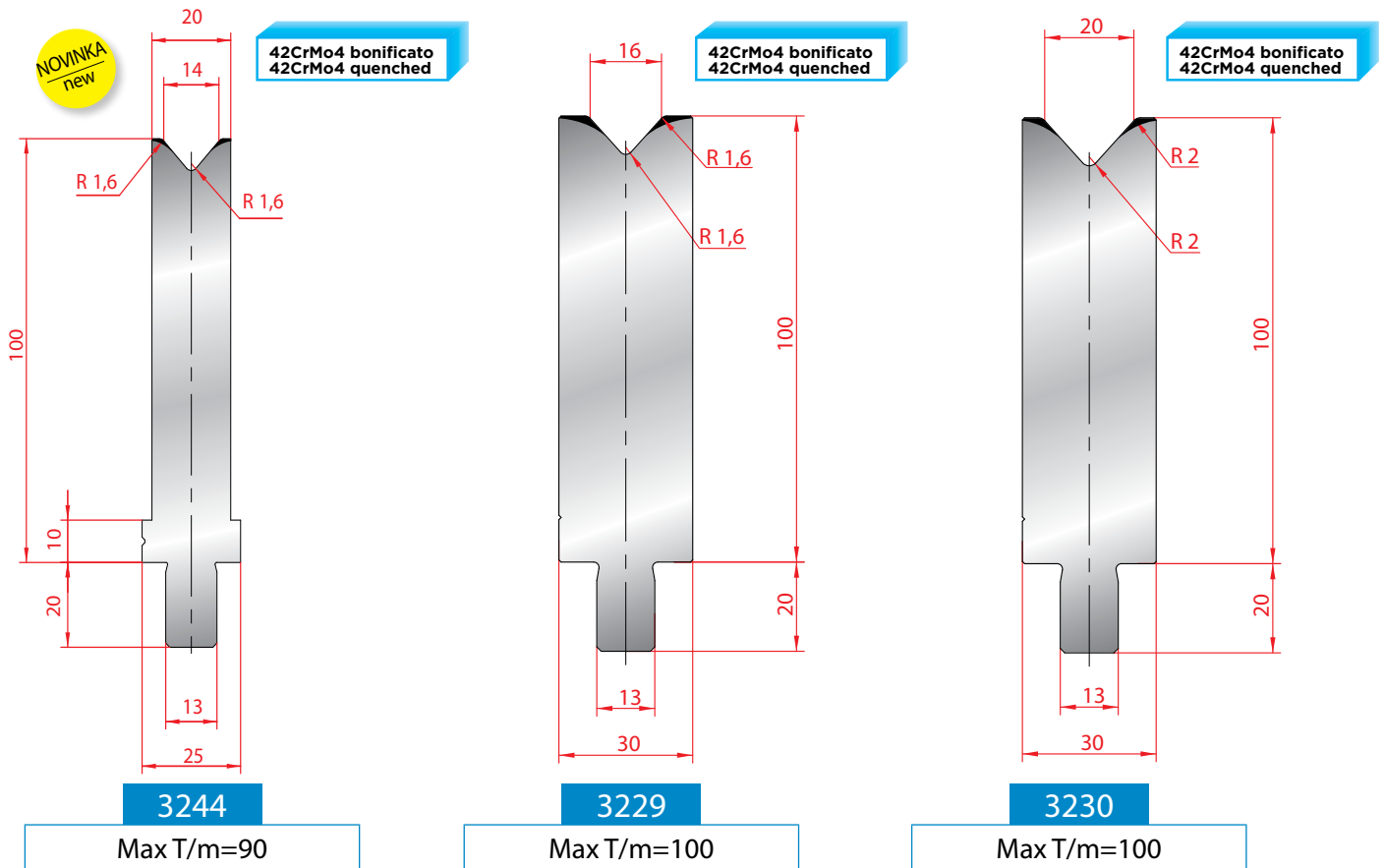

MATRICE 1V H100 - 80° / 1V DIES H100 - 80°

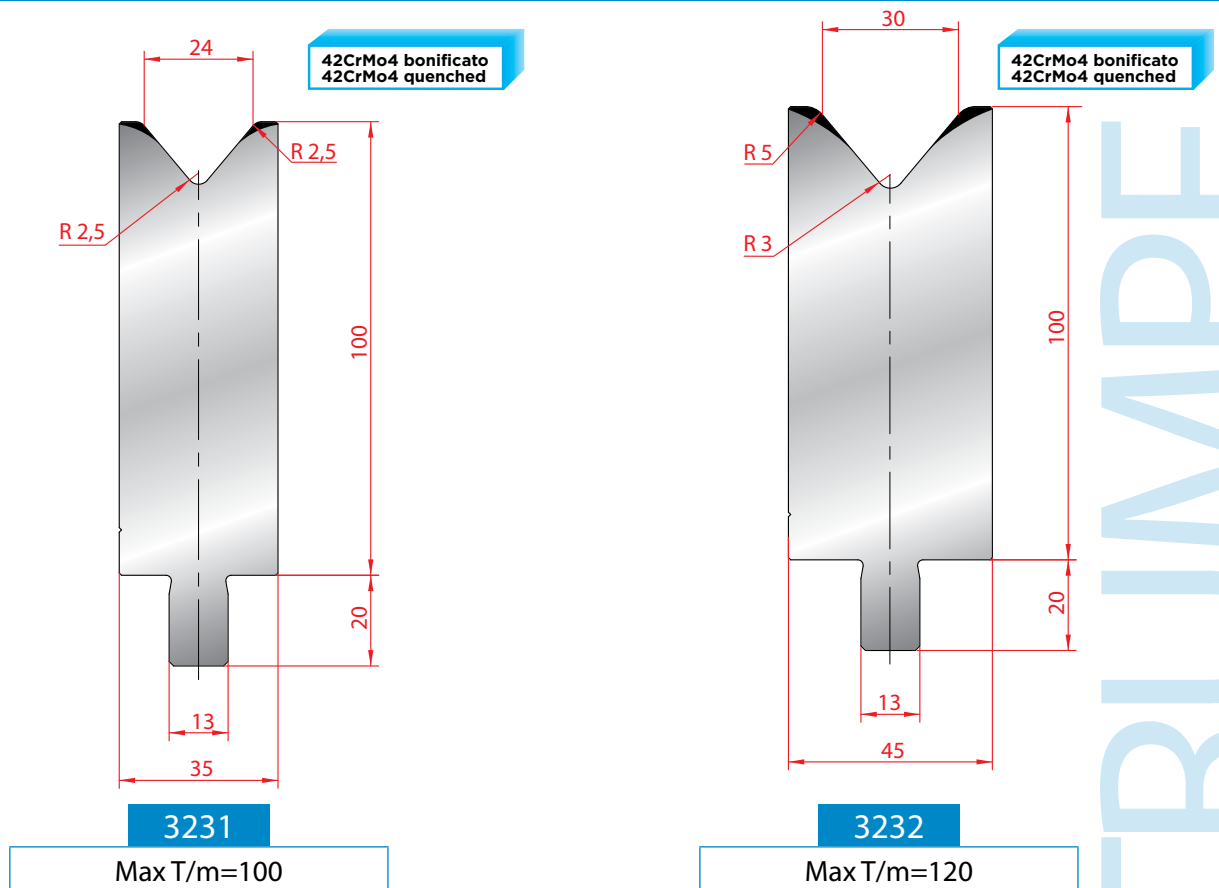

TRUMPF

MATRICE 1V H100 - 80° / 1V DIES H100 - 80°

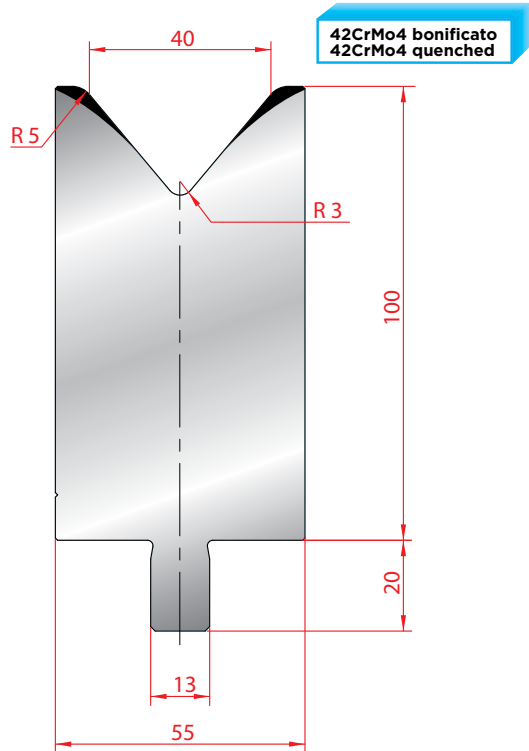

3233

Max T/m=150

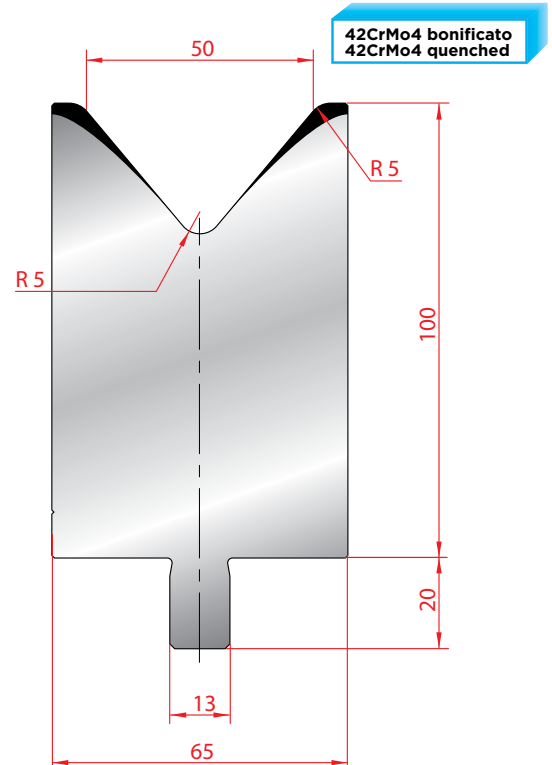

3234

Max T/m=150

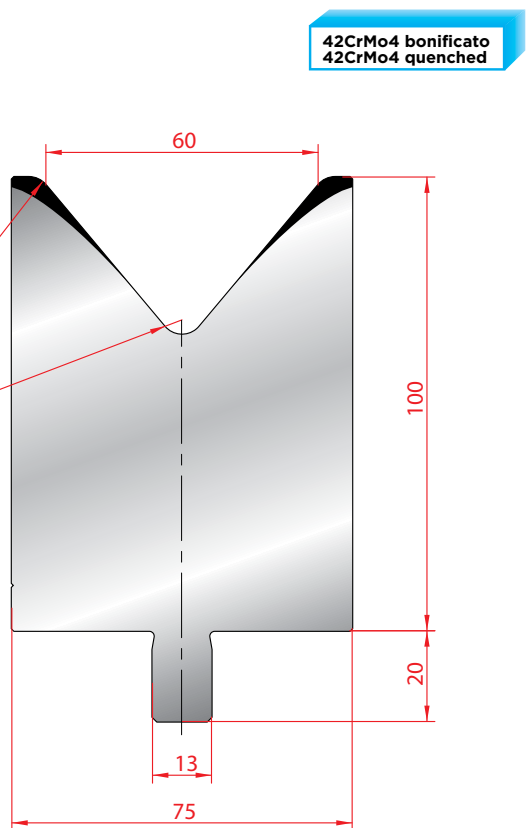

3219

Max T/m=150

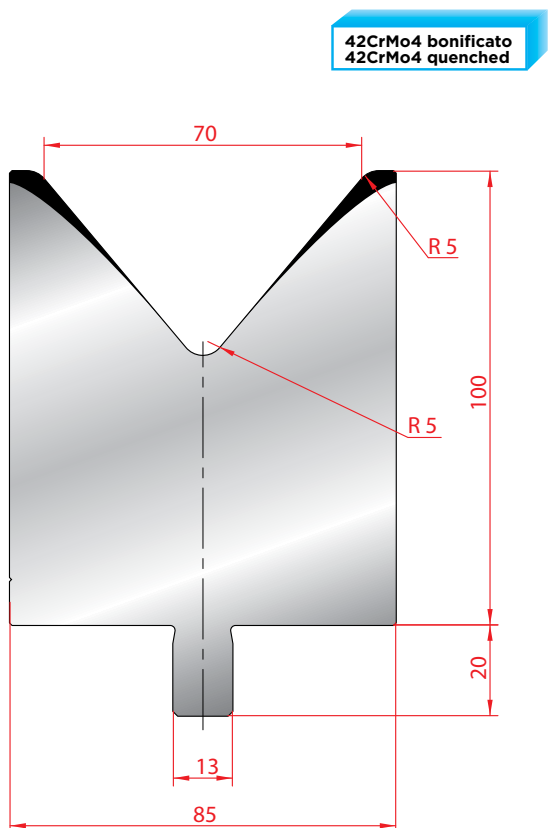

3220

Max T/m=150

TRUMPF

MATRICE 1V H100/120 - 80° / 1V DIES H100/120 - 80°

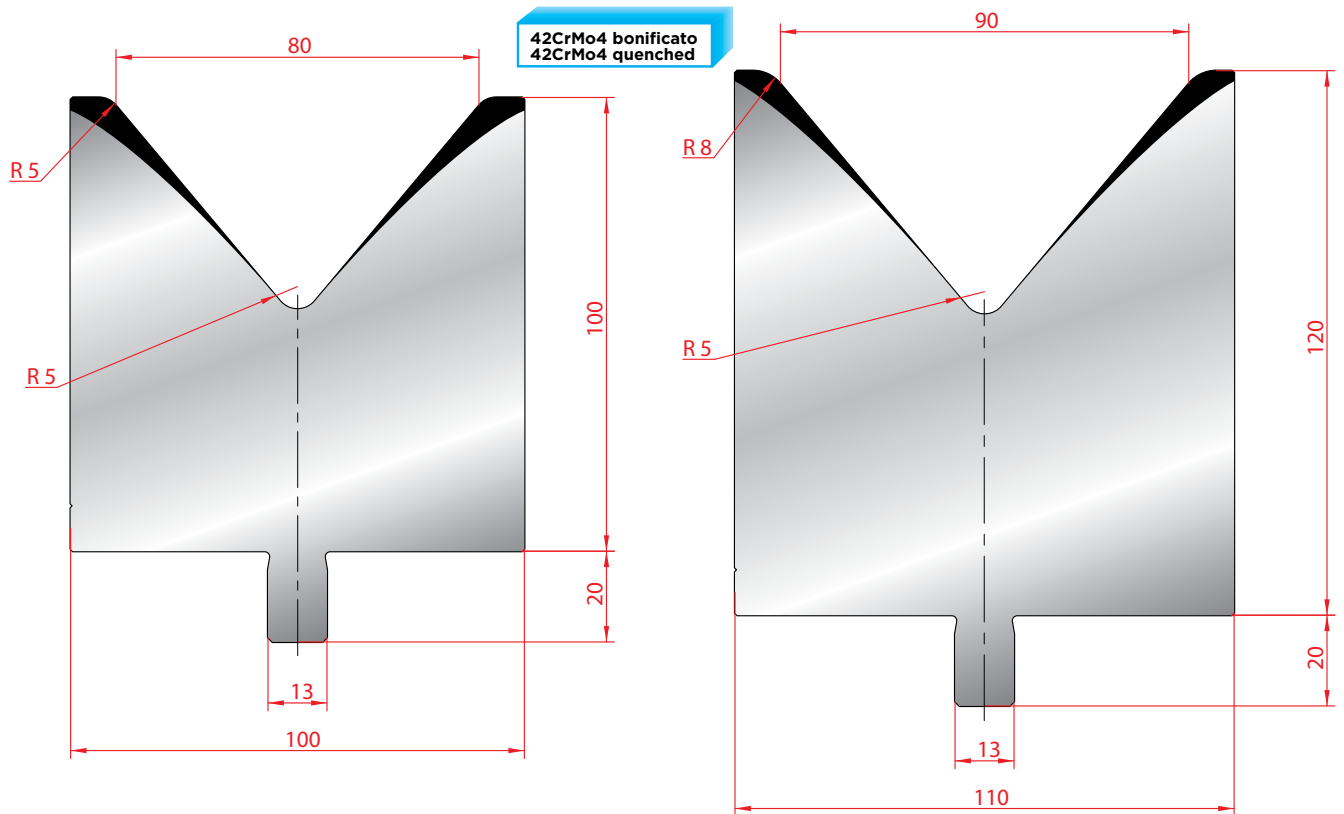

3221

Max T/m=150

3222

Max T/m=150

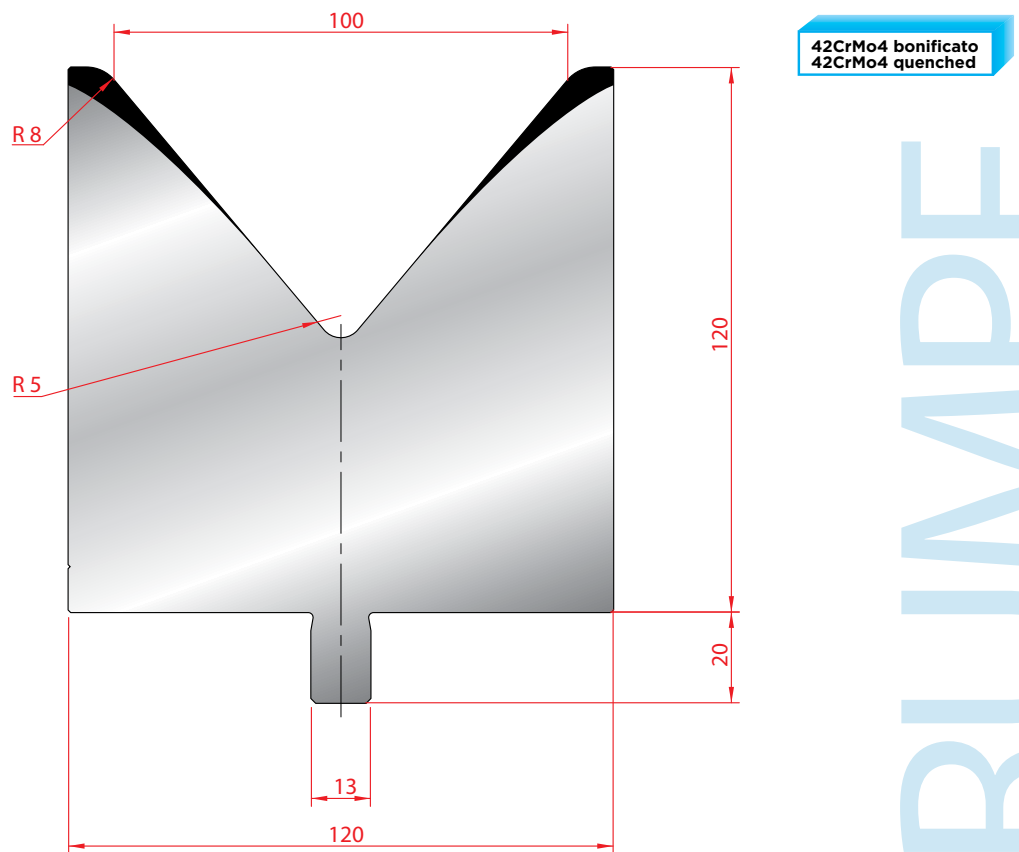

3223

Max T/m=150

TRUMPF

MATRICE 1V H120 - 60° / 1V DIES H120 - 60°

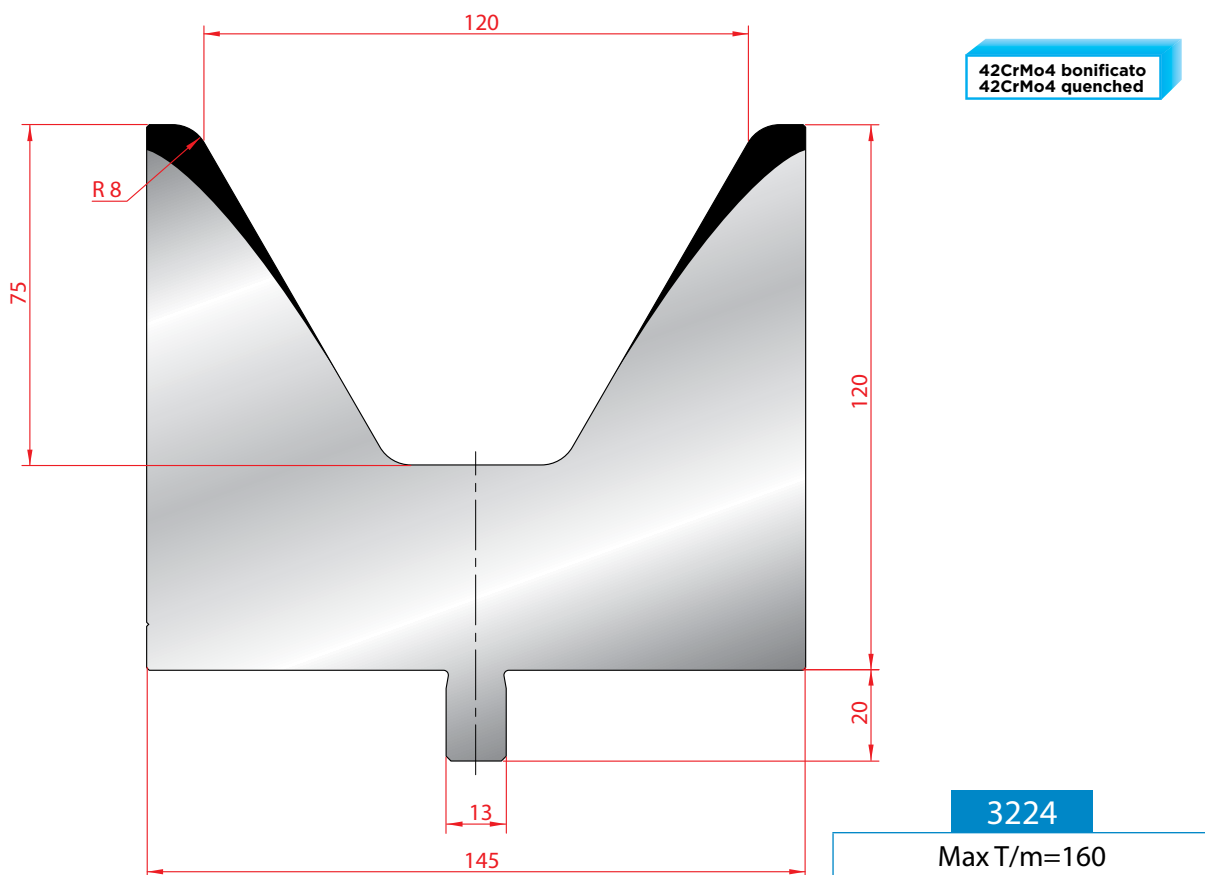

MATRICE 1V H100 - 30° / 1V DIES H100 - 30°

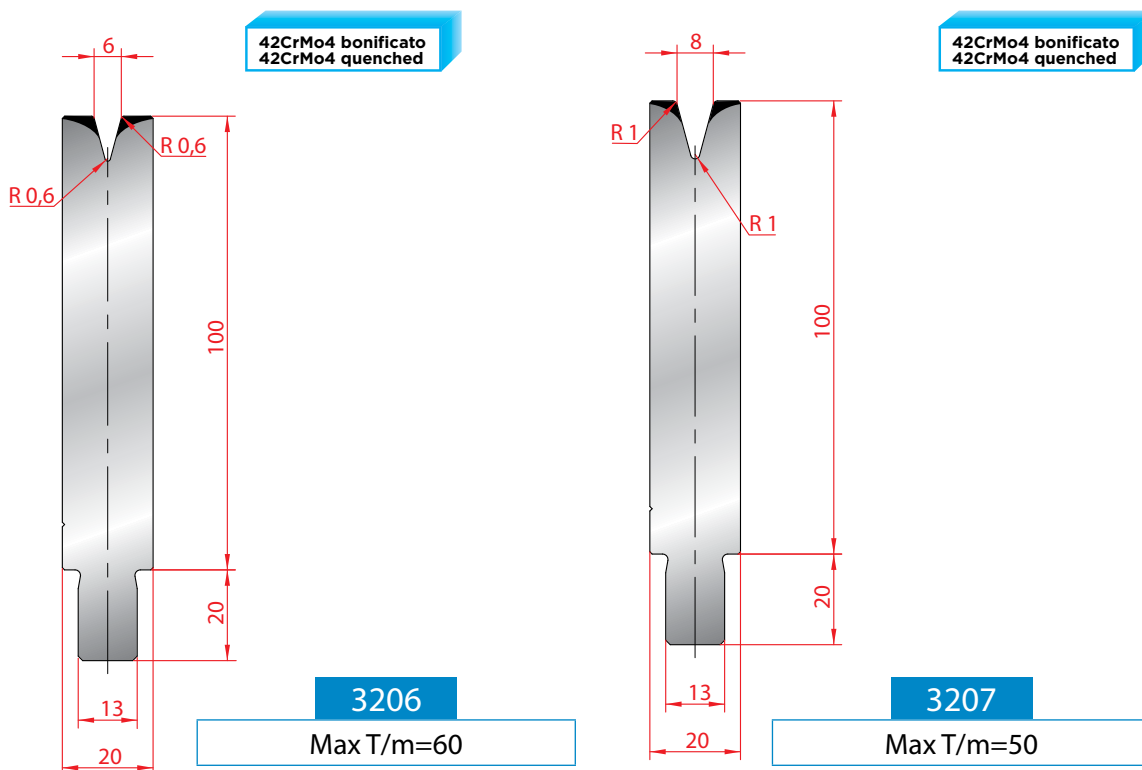

TRUMPF

MATRICE 1V H100 - 30° / 1V DIES H100 - 30°

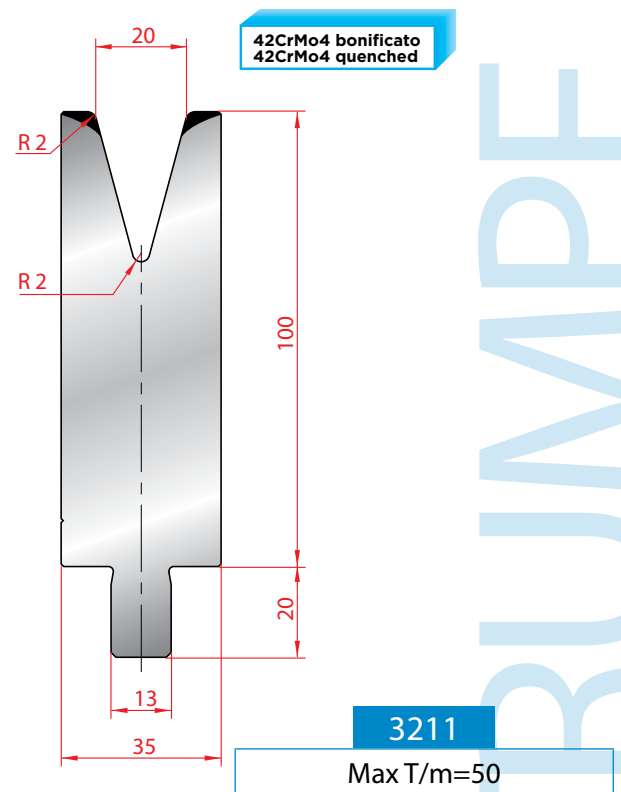
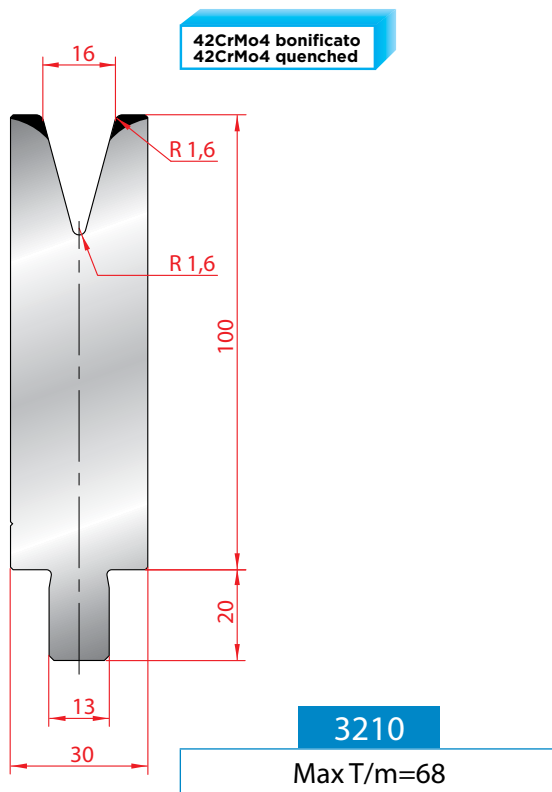
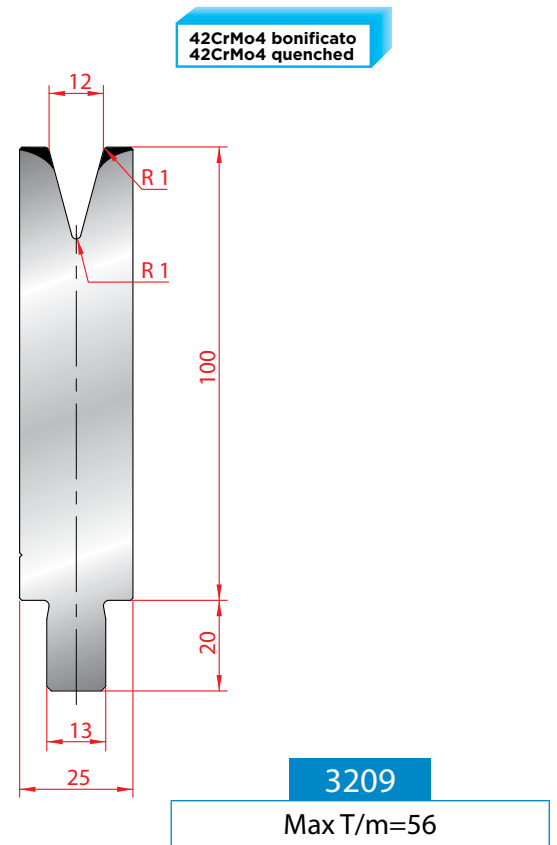
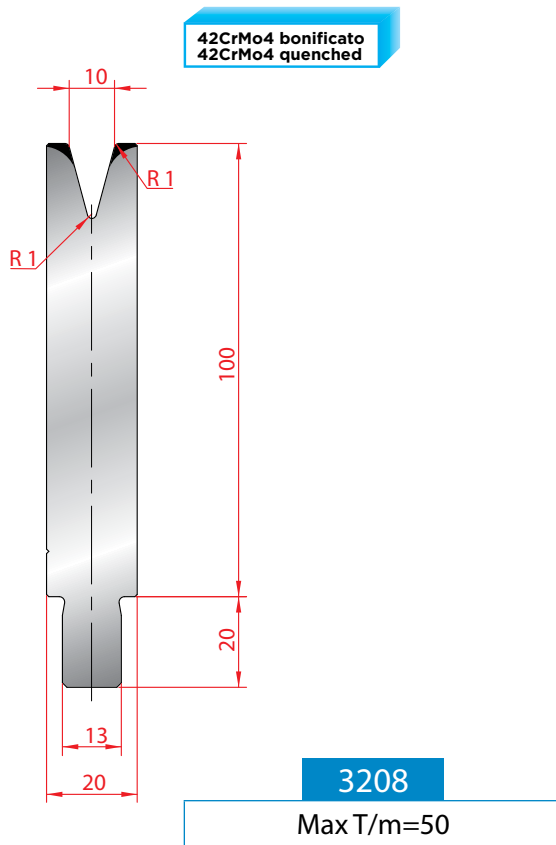

TRUMPF

MATRICE 1V H100 - 30° / 1V DIES H100 - 30°

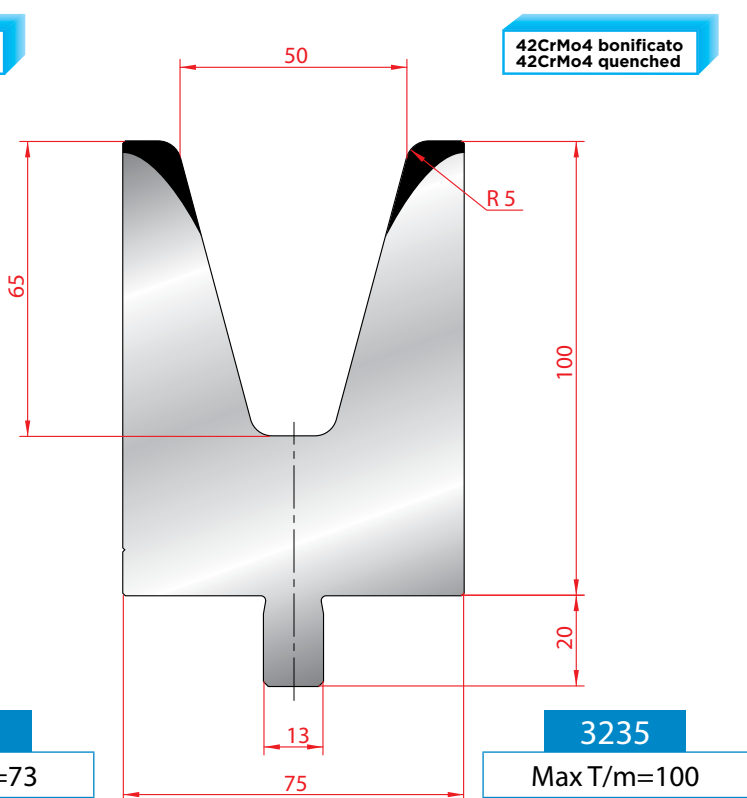
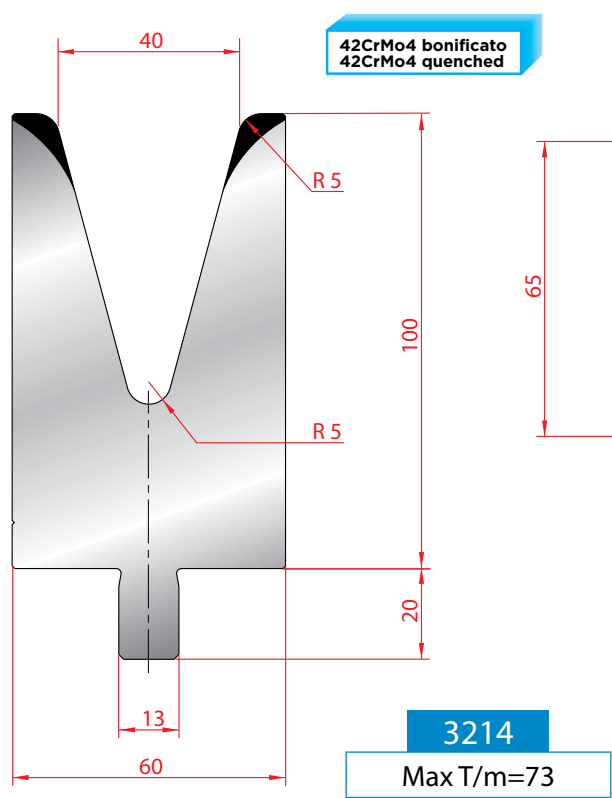
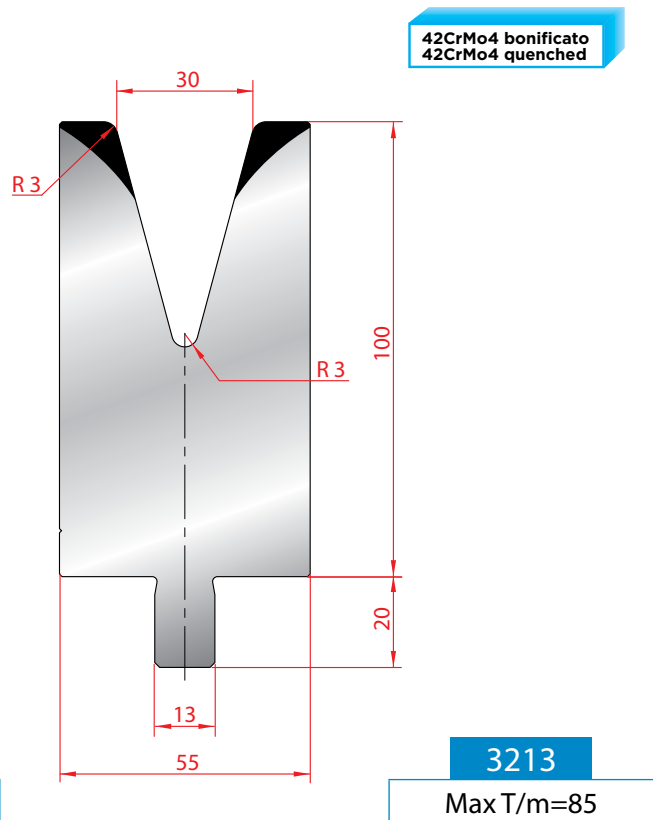
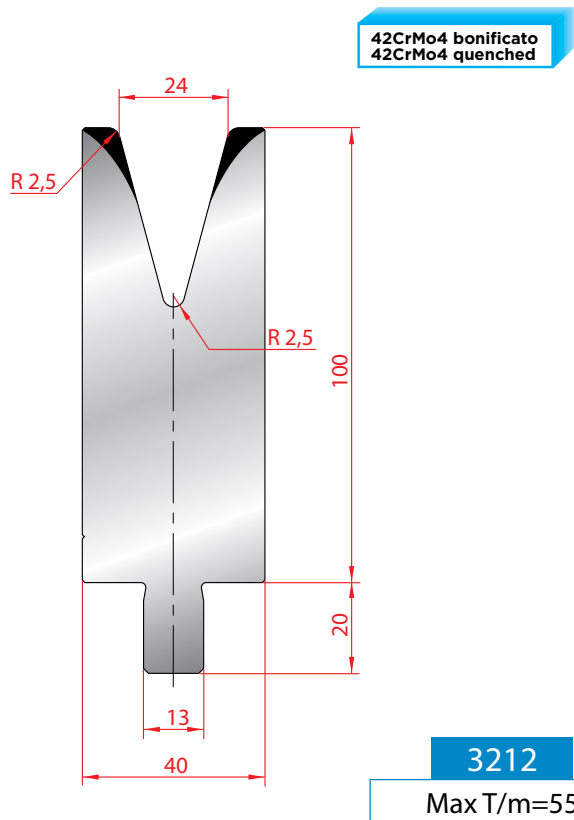

TRUMPF

MATRICE 1V H100 - 30° R3 / 1V DIES H100 - 30° R3

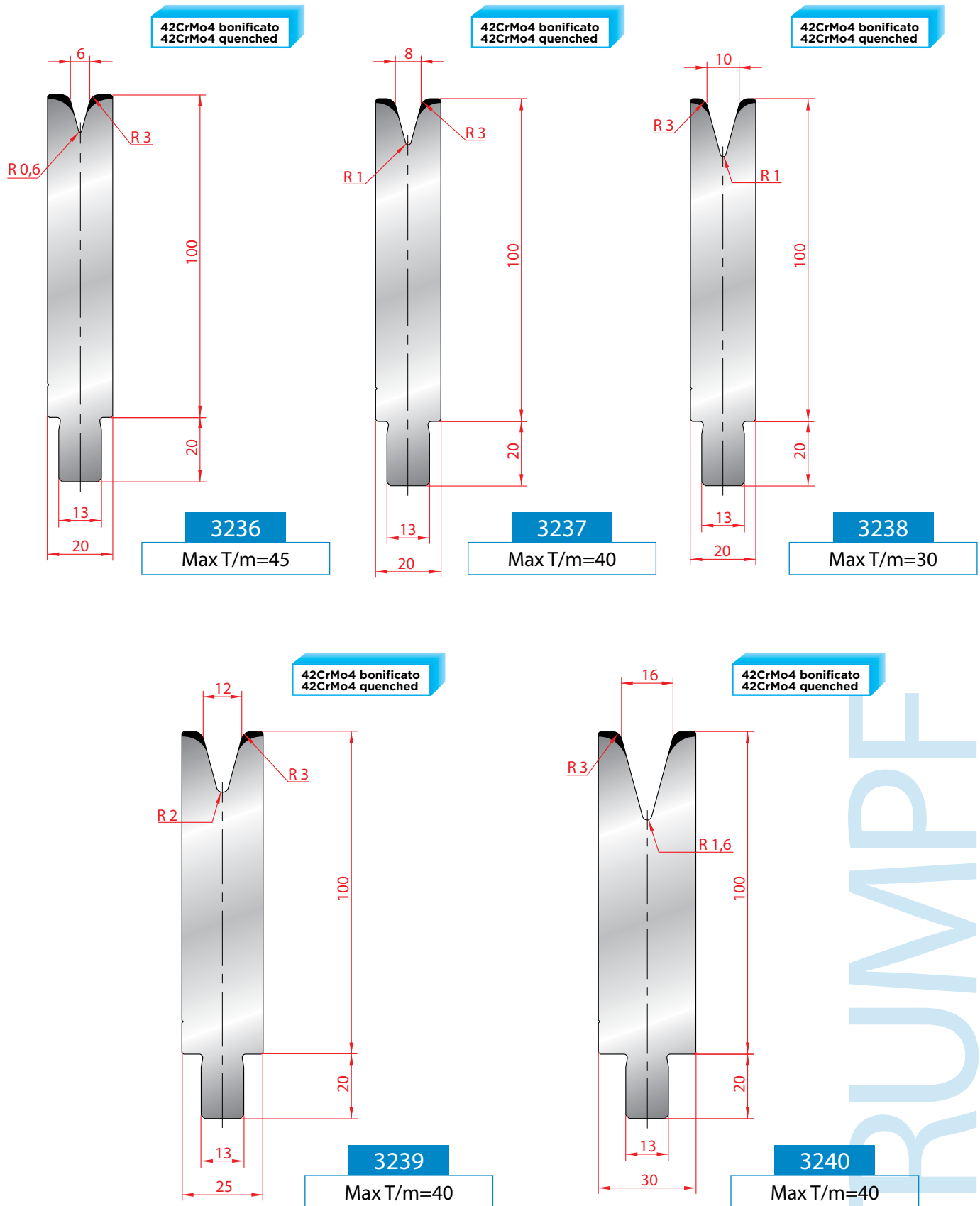

TRUMPF

MATRICE 1V H150 - 86° / 1V DIES H150 - 86°

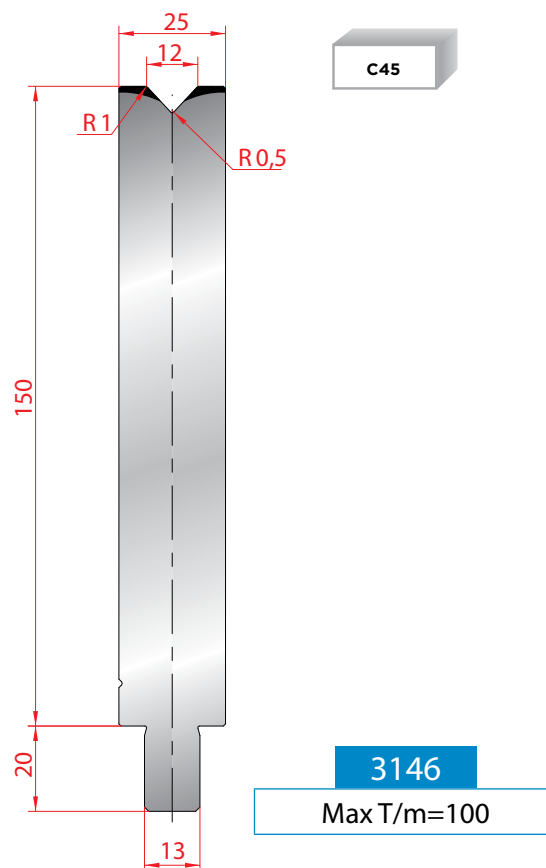
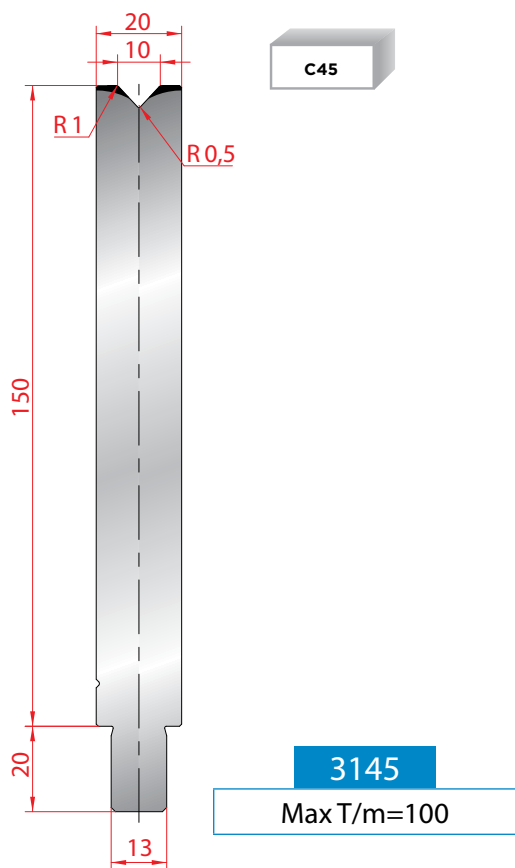
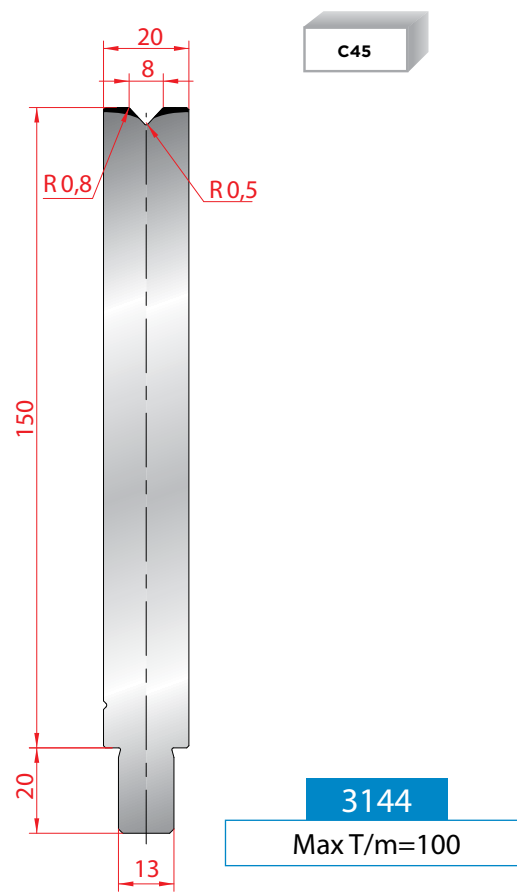
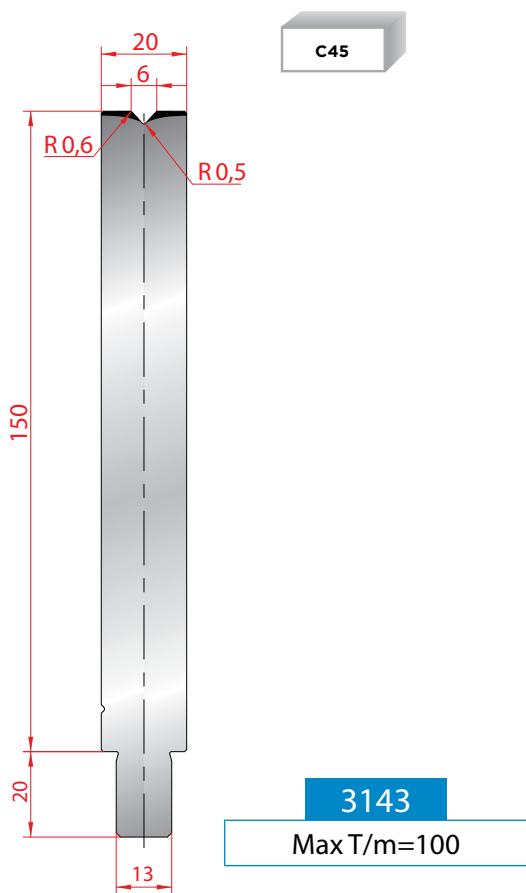

TRUMPF

MATRICE 1V H150 - 86° / 1V DIES H150 - 86°

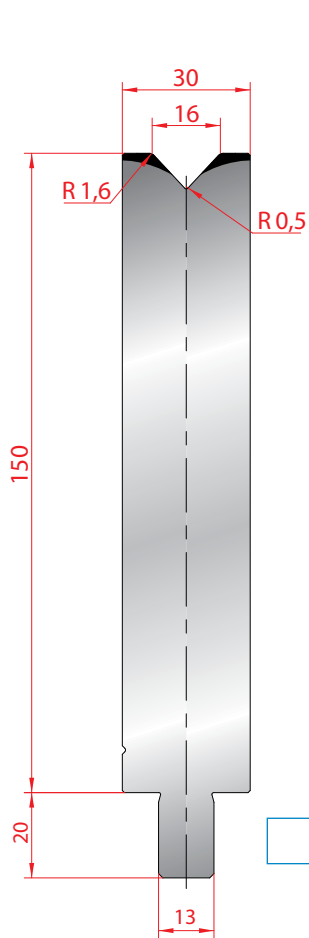

3147
Max T/m=100

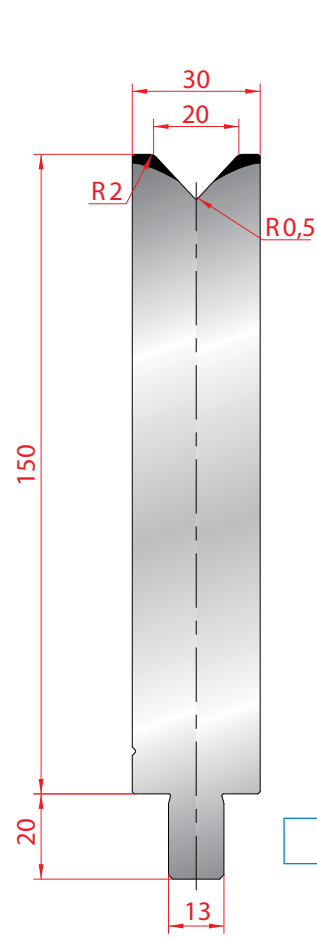

3148
Max T/m=100

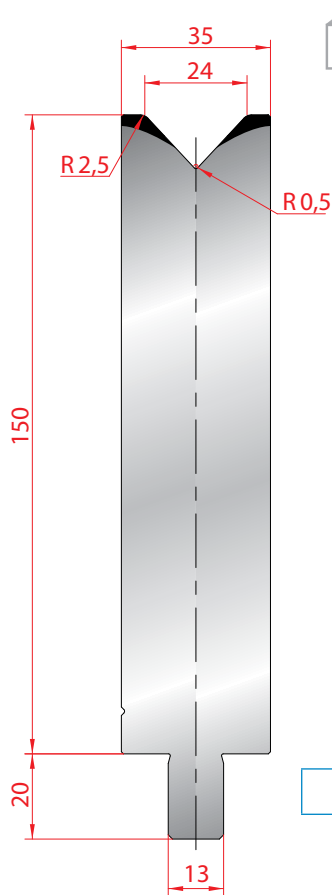

3149
Max T/m=100

TRUMPF

MATRICE 1V H150 - 30° / 1V DIES H150 - 30°

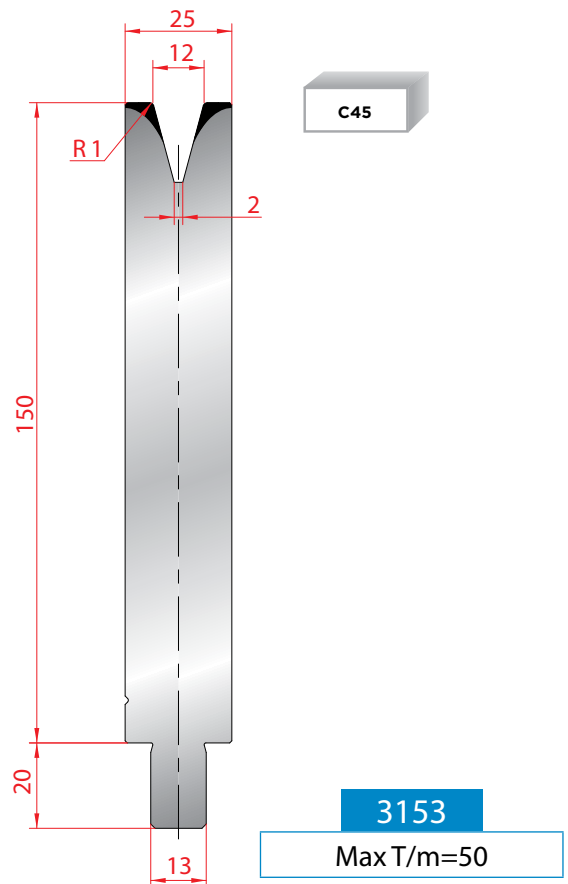
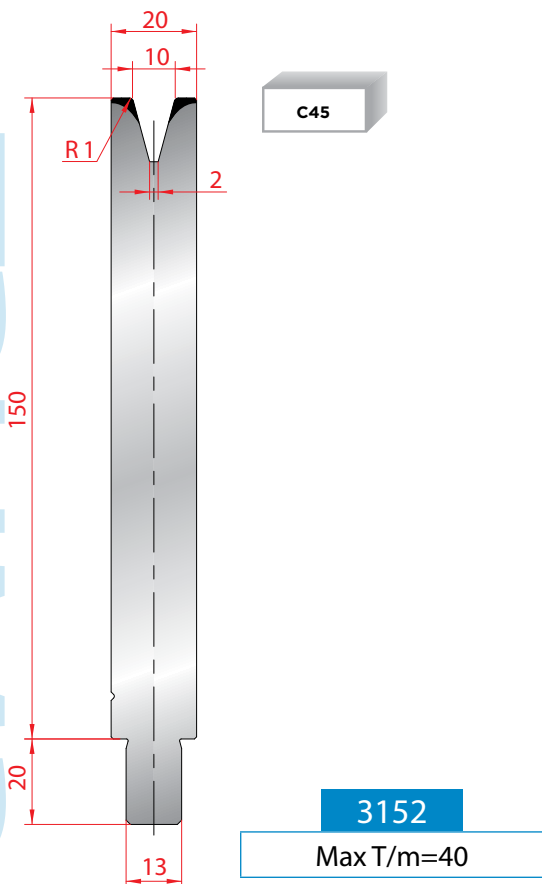
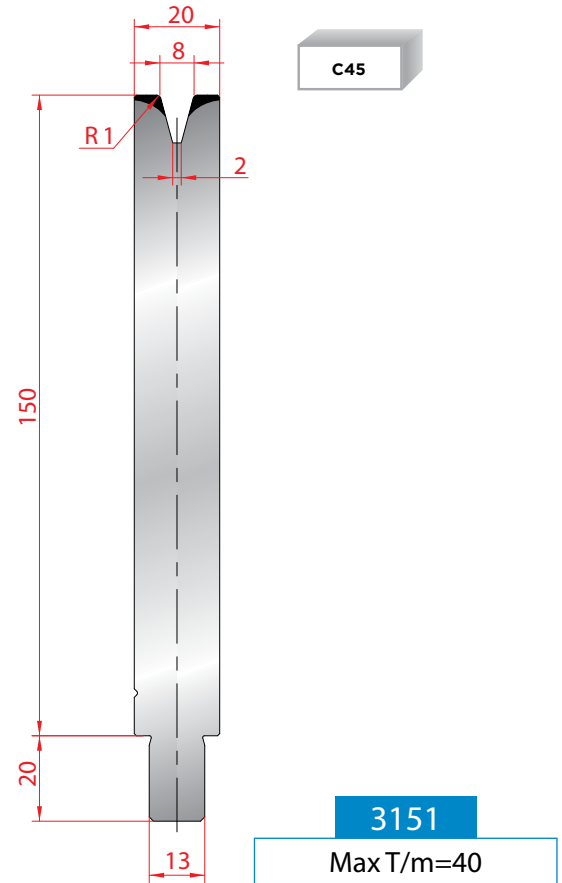
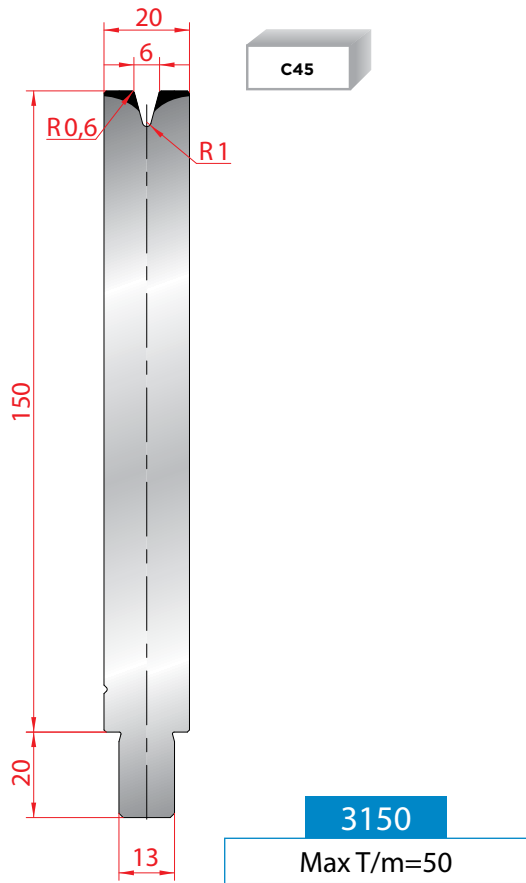

TRUMPF

MATRICE 1V H150 - 30° / 1V DIES H150 - 30°

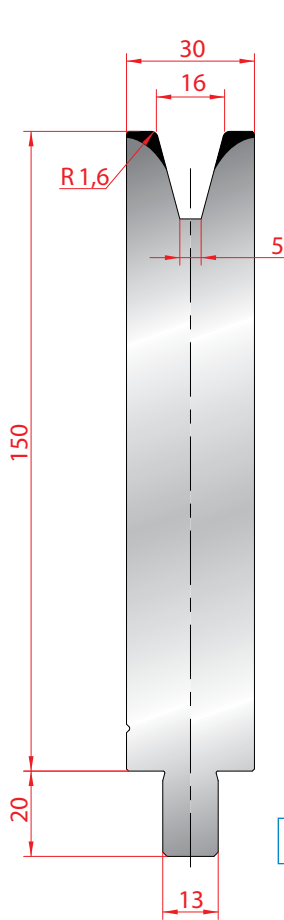

3154

Max T/m=45

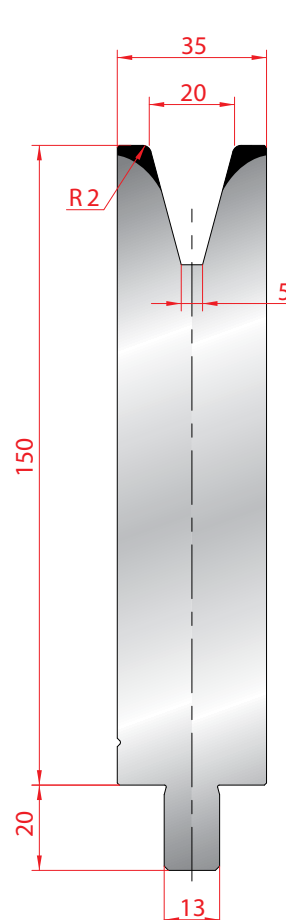

3155

Max T/m=50

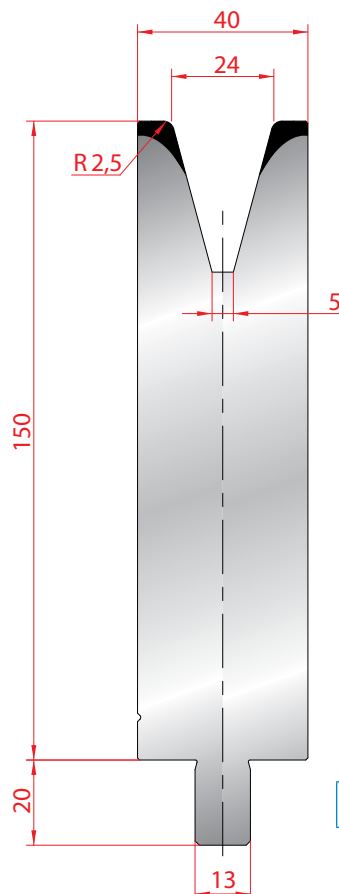

3156

Max T/m=50

TRUMPF

PERTLOVACÍ NÁSTROJE / FLATTENING-HEMMING TOOLS

1249

Max T/m=80

pro ocel o maximální tloušťce (Černý plech) 1,2 mm
max sheet metal thickness mild steel 1,2 mm

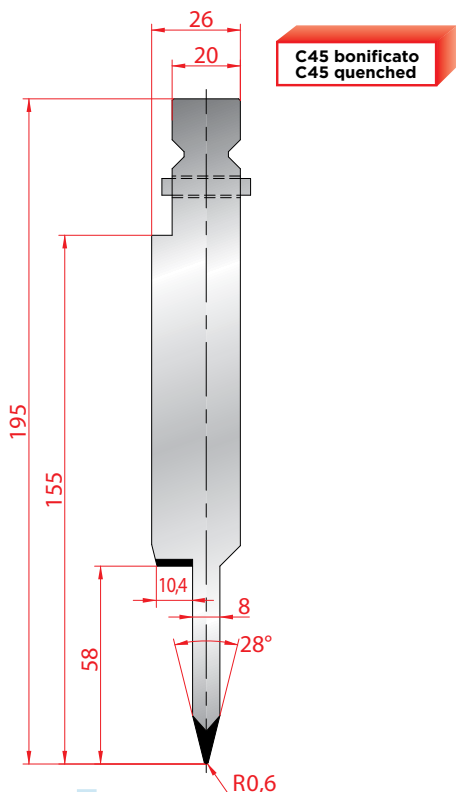

1250

Max T/m=50

pro ocel o maximální tloušťce (Černý plech) 1,5 mm
max sheet metal thickness mild steel 1,5 mm

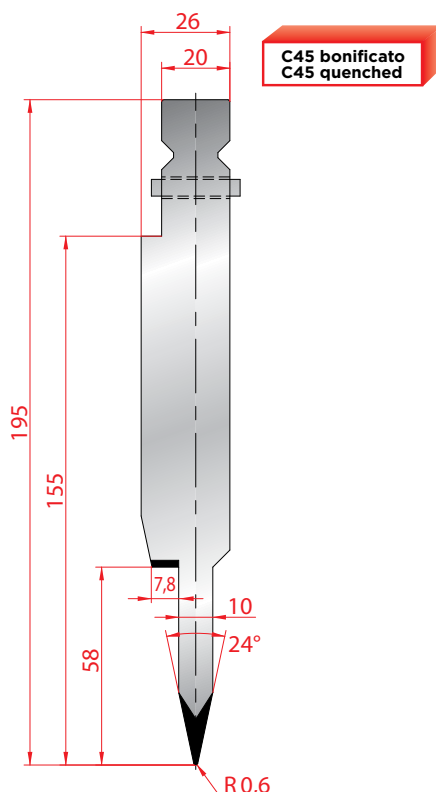

1251

Max T/m=50

pro ocel o maximální tloušťce (Černý plech) 1,5 mm
max sheet metal thickness mild steel 1,5 mm

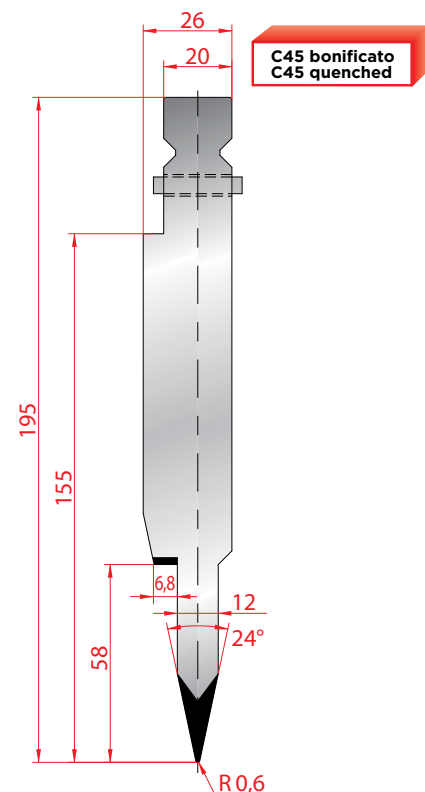

C45 bonificato
C45 quenched

C45 bonificato
C45 quenched

C45 bonificato
C45 quenched

C45 bonificato
C45 quenched

C45 bonificato
C45 quenched

C45 bonificato
C45 quenched

3157

Max T/m=50

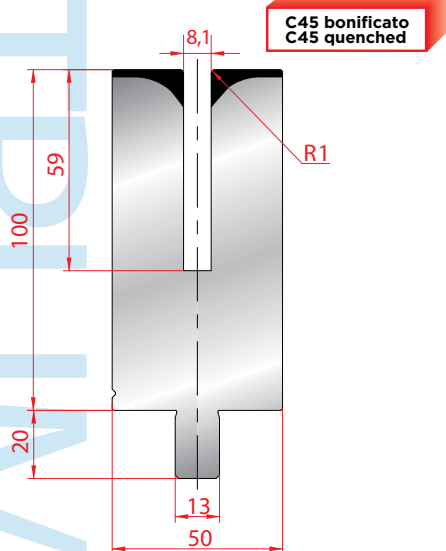

3174

Max T/m=50

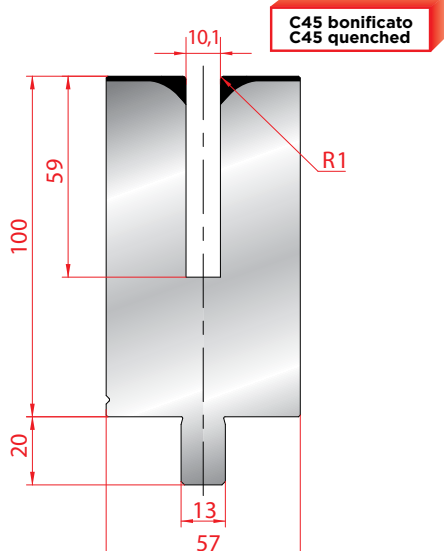

3175

Max T/m=50

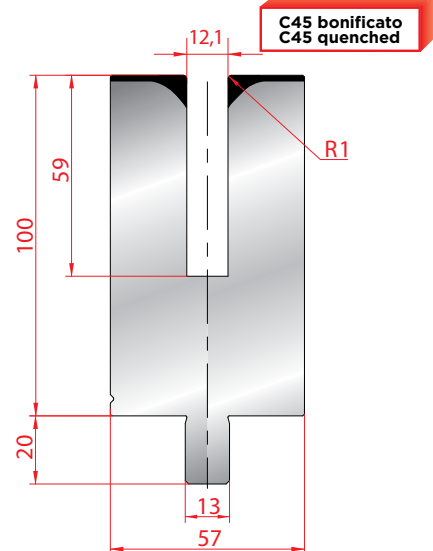

C45 bonificato
C45 quenched

C45 bonificato
C45 quenched

C45 bonificato
C45 quenched

C45 bonificato
C45 quenched

C45 bonificato
C45 quenched

C45 bonificato
C45 quenched