

ACCESSORIES

TOP spol. s r.o.
LANTIS

Press brake tooling and equipment

**UTENSILI E
ATTREZZATURE
PER PRESSE PIEGATRICI**

TOP
LAN TIS spol. s r.o.



Calcolo della forza di piega in aria

Air bending force calculation

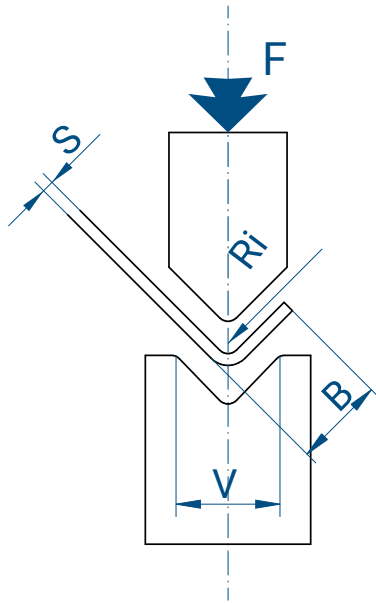

S	Spessore lamiera - mm Sheet metal thickness - mm	Ri	Raggio interno Inside radius
V	Larghezza del V V-opening	R	Alluminio 20-25 kg/mm ² Aluminium 20-25 kg/mm ²
F	Forza in T/m Force in T/m	R	Acciaio dolce 40-45 kg/mm ² Mild steel 40-45 kg/mm ²
B	Bordo minimo Shortest edge	R	Inox 65-70 kg/mm ² Stainless steel 65-70 kg/mm ²

$$F = \frac{S^2 \times 2 \times R}{1.4 \times V} = \dots \text{ ton/m}$$

Relazione tra spessore lamiera e larghezza V

Sheet metal thickness/V-shape width ratio

S	Spessore lamiera - mm Sheet metal thickness - mm	0,5-2,5	3-8	9-10	12 o più 12 or more
V	Larghezza del V "V" width	6 S	8 S	10 S	12 S



Tabella di piegatura in aria - Acciaio dolce / Air bending table - Mild Steel

S			mm	0,5	0,6	0,8	1	1,2	1,5	2	2,5	3	4	5	6	8	10	12	15	20	25	30	
6	4	1		3	4	7	11	16															
8	5,5	1,3			4	5	8	12	17														
10	7	1,6				4	7	10	15	27													
12	8,5	2					6	8	13	22	35												
16	11	2,6						6	9	17	26	38											
20	14	3,3							8	13	21	30	54										
25	17,5	4								11	17	24	42	67									
32	22	5									13	19	34	52	75								
40	28	6,5										15	27	42	60	107							
50	35	8											21	33	48	85	134						
63	45	10												26	38	68	105						
80	55	13													30	53	85	120					
100	71	16														43	67	96	150				
125	89	20															53	78	120	215			
160	113	26																60	95	170	265		
200	140	33																	75	135	210	300	
250	175	41																		108	170	240	
320	226	53																			85	130	190
V	B	Ri																					F

t/m

Tabella di piegatura in aria - Acciaio inox / Air bending table - Stainless Steel

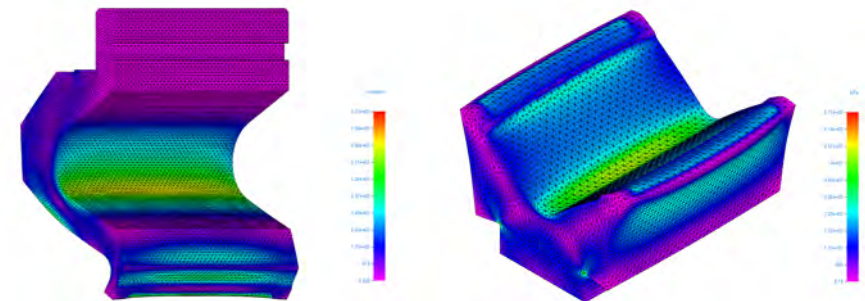
S			mm	0,5	0,6	0,8	1	1,2	1,5	2	2,5	3	4	5	6	8	10	12	15	20	25	30	
6	4	1		5	6	11	17	25															
8	5,5	1,3			6	8	12	19	26														
10	7	1,6				6	11	16	23	42													
12	8,5	2					9	12	20	34	54												
16	11	2,6						9	14	26	40	59											
20	14	3,3							12	20	33	47	84										
25	17,5	4								17	26	37	65	104									
32	22	5									20	30	53	81	117								
40	28	6,5										23	42	65	93	166							
50	35	8											33	51	75	132	208						
63	45	10												40	59	106	163						
80	55	13													47	82	132	187					
100	71	16														67	104	149	233				
125	89	20															82	121	187	334			
160	113	26																93	148	264	412		
200	140	33																	117	210	327	467	
250	175	41																		168	264	373	
320	226	53																			132	202	296
V	B	Ri																					F

t/m

ACCESSORI ACCESSORIES

• Supporti per elementi raggiati / Radius tools holders	10-12	• Staffe / Clamps	58-61
• Elementi raggiati / Radius tools	13-21	• Supporti inferiori per matrici regolabili / Lower support for adjustable dies	62
• Elemento quadro e accessori / Flattening insert and accessories	22	• Matrici regolabili / Adjustable dies	63-64
• Contenitori a "Z" / Joggle tool holders Amada-Promecam / Wila-Trumpf	23	• Foto	65
• Tabella inserti a Z / Joggle Tools chart	24	• Protezione dalle marcature/ Protection against marks	66
• Inserti a Z / Joggle tools 140 - 150 - 160°	25	• Foto	67
• Inserti a Z / Joggle tools 90°	26-31	• Complementi Ausiliari	68-69
• Contenitori e inserti in nylon / Nylon insert and holders	32-33	• Goniometro manuale / Manual protractor	70
• Contenitori e inserti in poliuretano / Polyurethane inserts and Holders	34-35	• Calibro digitale / Digital gauge	71
• Sistema Eurogrip	36-43	• Armadi porta utensili / Tooling cabinets	72-73
• Adattatori generici per utensili superiori Amada-Promecam Amada-Promecam generic upper tool adapters	44	• Foto	74
• Adattatori per utensili inferiori Amada-Promecam / Amada-Promecam lower tool adapters	45	• Matrici multicava a richiesta / Multi V dies on request	75
• Attacchi su richiesta / Tangs on request	46-47	• Utensili LVD su richiesta / LVD tools on request	76
• Adattatori specifici per utensili superiori Amada-Promecam / Amada-promecam specific upper tool adapters	48-52	• Utensili LVD-WILA su richiesta / LVD-WILA tools on request	76-77
• Foto	53	• Utensili Weinbrenner su richiesta / Weinbrenner tools on request	77
• Adattatori inferiori / Lower Adapter	54-55	• Utensili EHT su richiesta / EHT tools on request	77
• Intermediari registrabili / Adjustable intermediates	56	• Utensili speciali su richiesta / Special tools on request	78-79
• Intermediari fissi / Fixed intermediates	57	• Lame per cesoia / Shear blades	80-81
		• Trattamenti termici speciali su richiesta / Special heat treatments on request	82

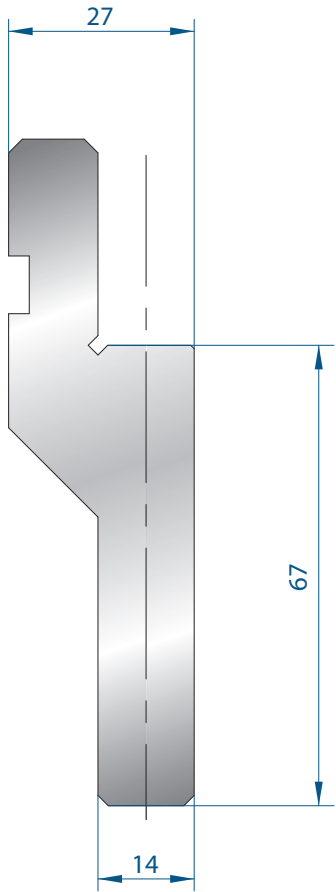

1036

Amada Promecam
Mat = C45
Max T/m = 100

830 mm	10,0 kg
410 mm	5,0 kg

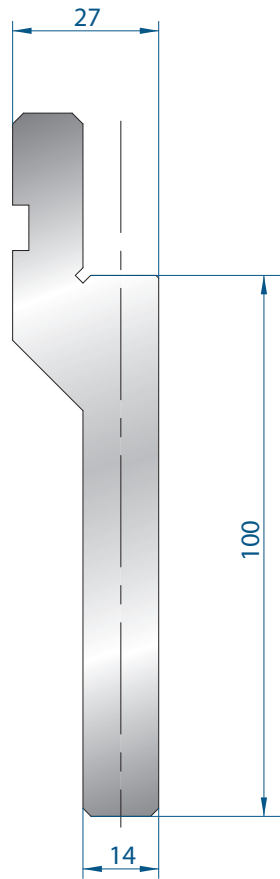

1096

Amada Promecam
Mat = C45
Max T/m = 100

830 mm	13,0 kg
410 mm	6,0 kg

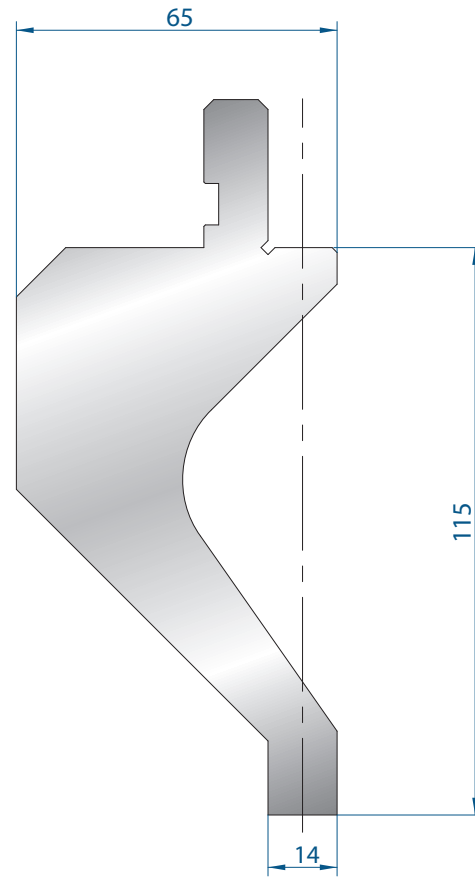

1090

Amada Promecam
Mat = C45
Max T/m = 50

830 mm	26,0 kg
410 mm	13,0 kg

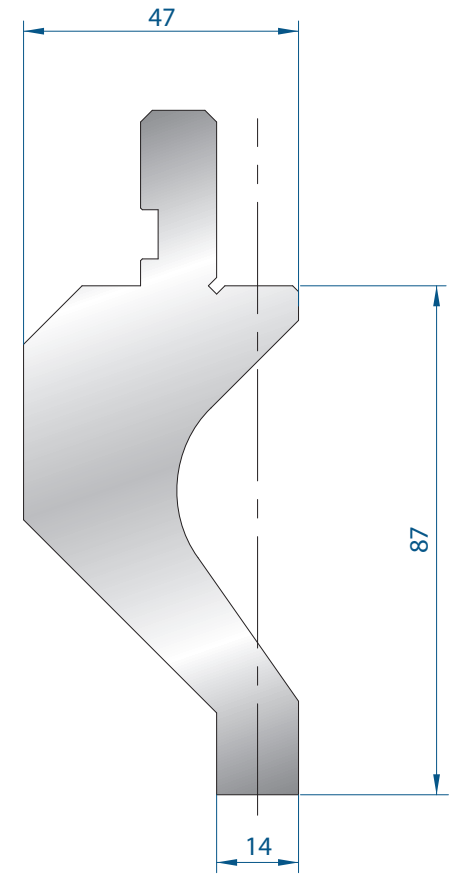

1091

Amada Promecam
Mat = C45
Max T/m = 50

830 mm	16,0 kg
410 mm	8,0 kg



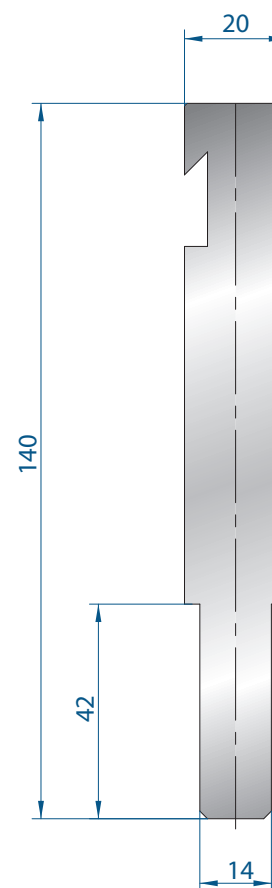
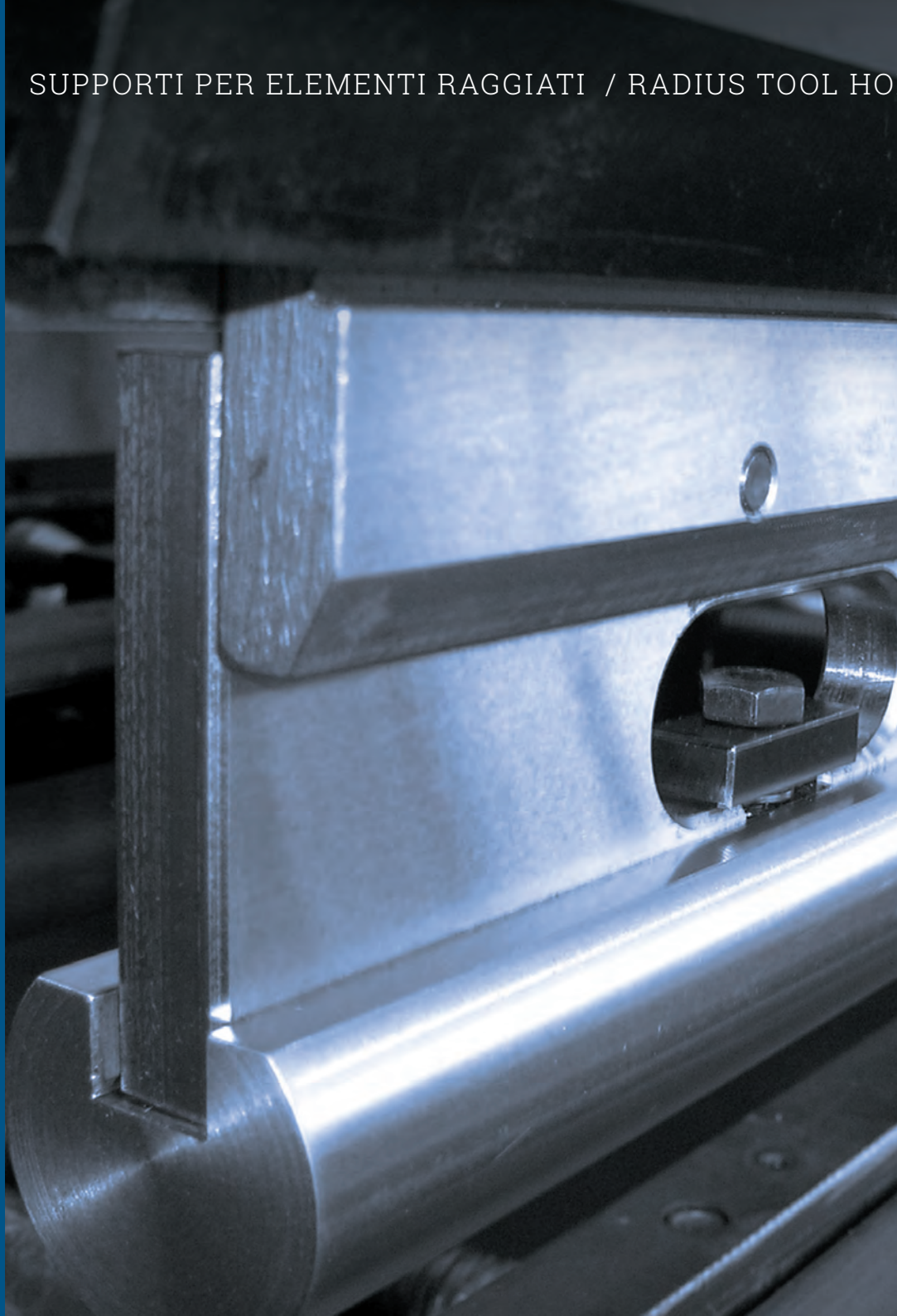

1239

Bystronic R
Mat = C45
Max T/m = 100

830 mm	15,0 kg
410 mm	7,0 kg

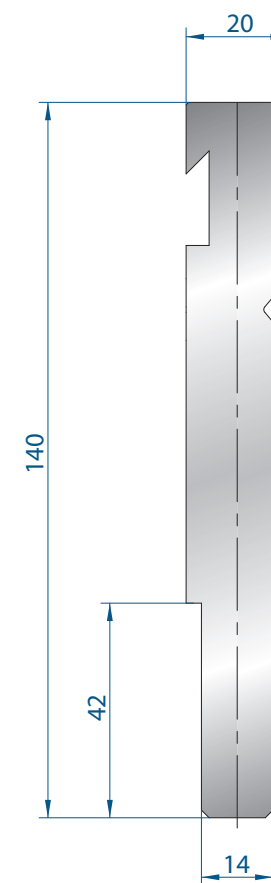

1273

Bystronic RF - A
Mat = C45
Max T/m = 100

830 mm	16,0 kg
410 mm	8,0 kg

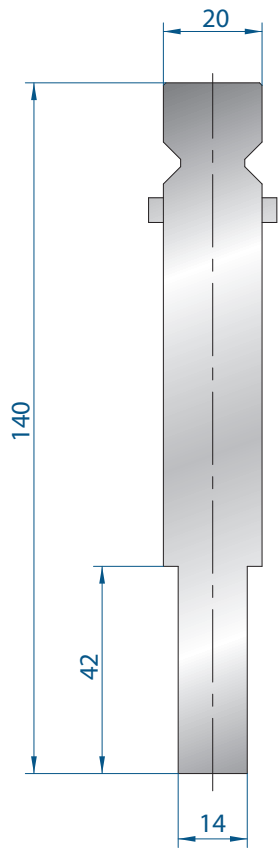

1240

Trumpf / Wila
Mat = C45
Max T/m = 100

830 mm	16,0 kg
410 mm	8,0 kg

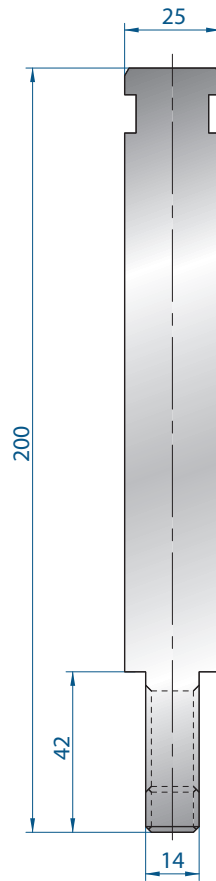

1305

Weinbrenner
Mat = C45
Max T/m = 100

830 mm	28,0 kg
410 mm	14,0 kg

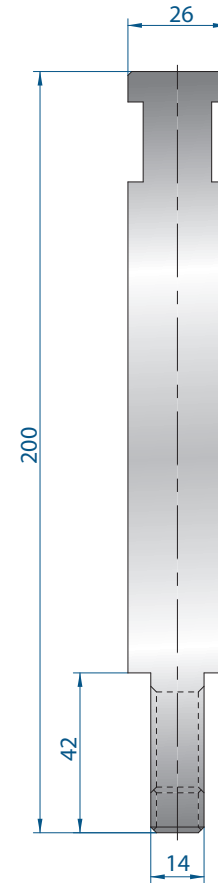

1306

EHT
Mat = C45
Max T/m = 100

830 mm	28,0 kg
410 mm	14,0 kg



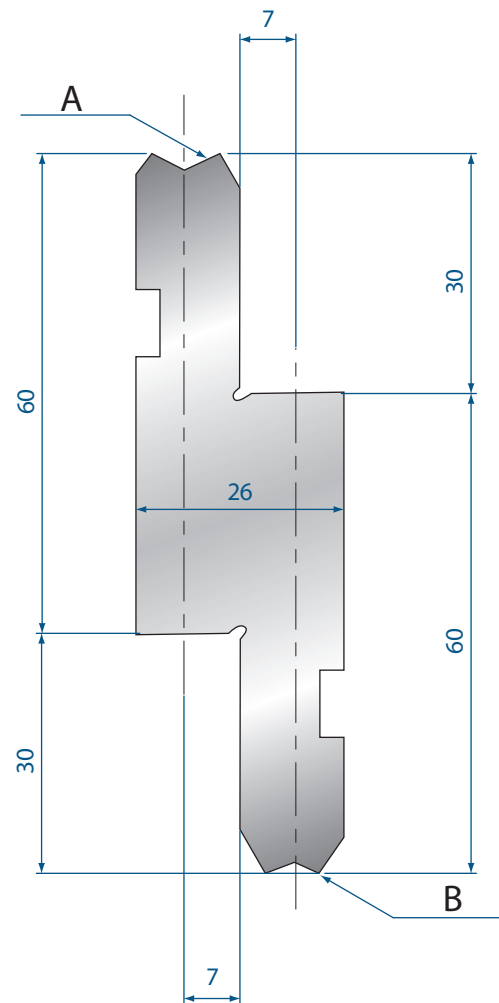

1155

Amada/Promecam
Mat = C45

830 mm	9,0 kg
410 mm	4,0 kg

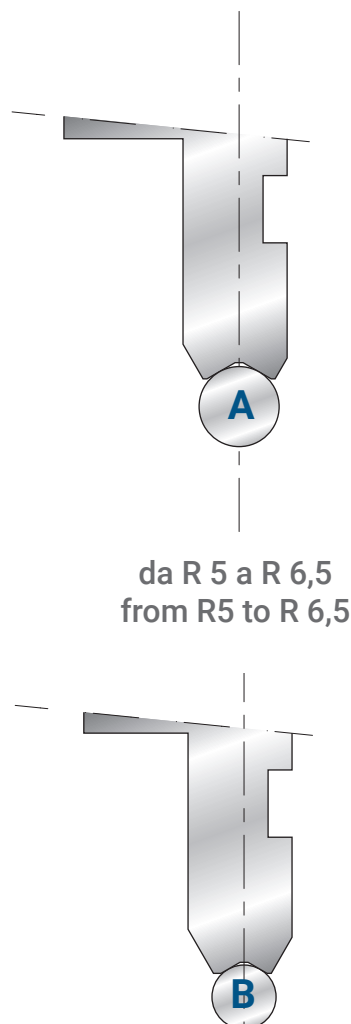

da R 5 a R 6,5
from R 5 to R 6,5

da R 3 a R 4,5
from R 3 to R 4,5

4275

Pezzo di ricambio /
spare part

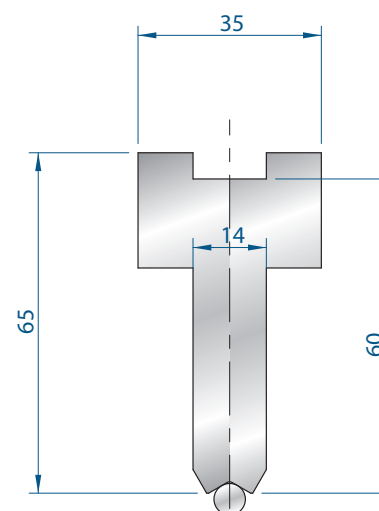
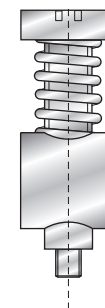

1297

EHT
da R 5 a R 6,5
from R 5 to R 6,5

830 mm	8,0 kg
410 mm	4,0 kg

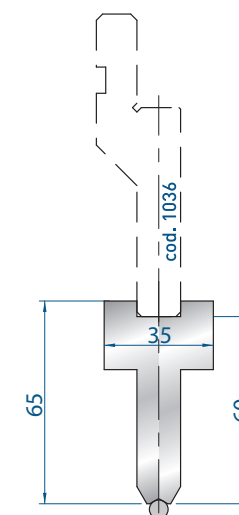

1296

EHT
da R 3 a R 4,5
from R 3 to R 4,5

830 mm	8,0 kg
410 mm	4,0 kg

1180

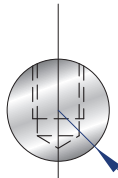

Mat = C45

835 mm	1,0 kg
415 mm	0,5 kg

R 3

1181

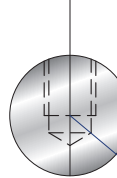

Mat = C45

835 mm	1,0 kg
415 mm	0,5 kg

R 3,5

1182

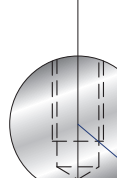

Mat = C45

835 mm	1,0 kg
415 mm	0,5 kg

R 4

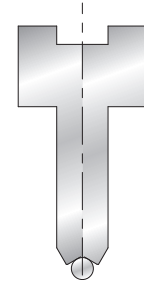

1183

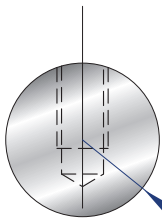

Mat = C45

835 mm	1,0 kg
415 mm	0,5 kg

R 4,5

1184

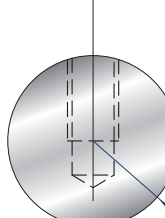

Mat = C45

835 mm	1,0 kg
415 mm	0,5 kg

R 5

1185

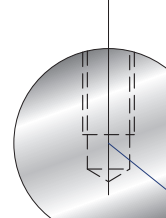

Mat = C45

835 mm	1,0 kg
415 mm	0,5 kg

R 5,5

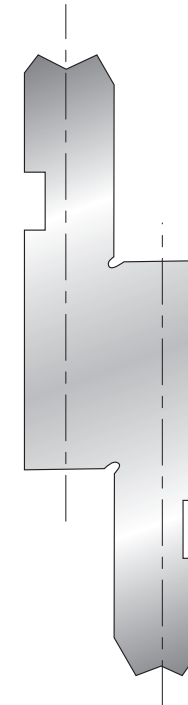

1186

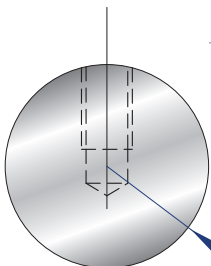

Mat = C45

835 mm	1,0 kg
415 mm	0,5 kg

R 6

1187

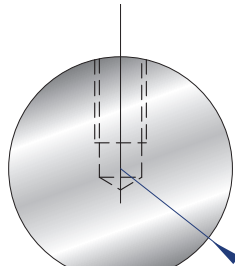

Mat = C45

835 mm	1,0 kg
415 mm	0,5 kg

R 6,5

SOLO PER SUPPORTI 1155 - 1296 - 1297
ONLY FOR HOLDERS 1155 - 1296 - 1297



1100

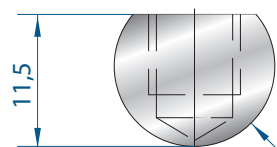

Mat = C45

835 mm	0,8 kg
415 mm	0,4 kg

R7

1101

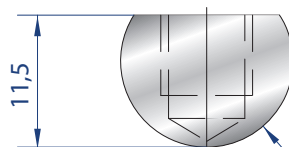

Mat = C45

835 mm	1,0 kg
415 mm	0,5 kg

R 7,5

1102

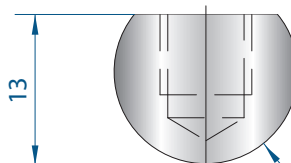

Mat = C45

835 mm	1,0 kg
415 mm	0,5 kg

R 8

1103

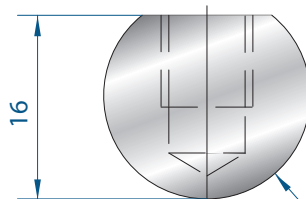

Mat = C45

835 mm	1,0 kg
415 mm	0,5 kg

R 9

1037

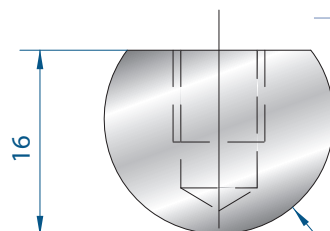

Mat = C45

835 mm	2,0 kg
415 mm	1,0 kg

R 10

1104

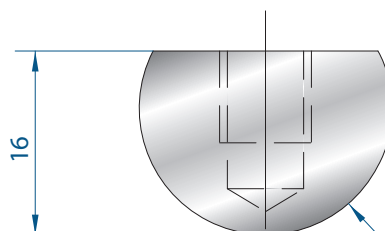

Mat = C45

835 mm	2,0 kg
415 mm	1,0 kg

R 11

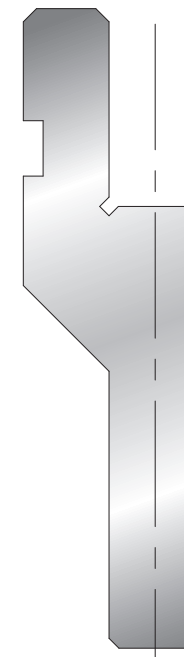

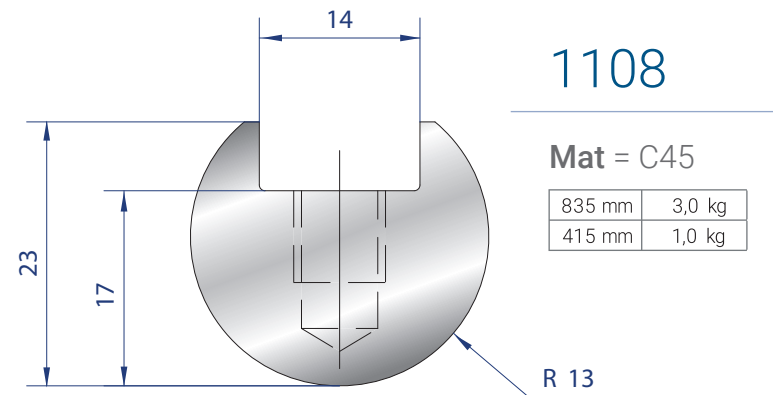
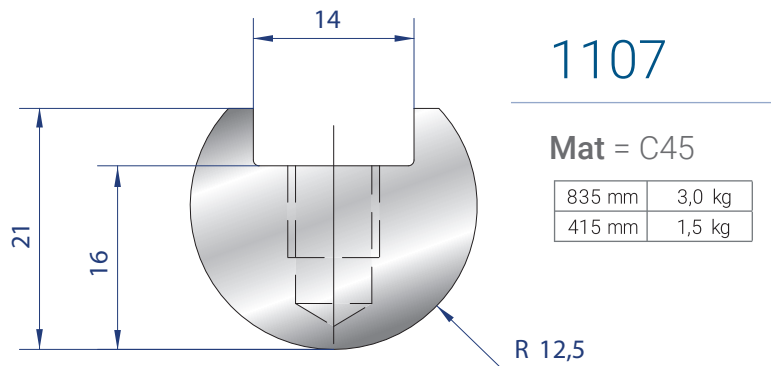
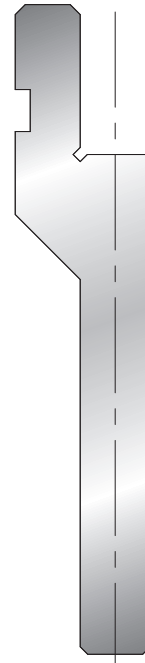
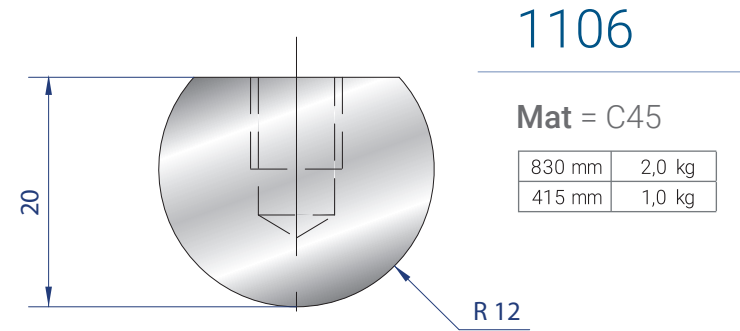
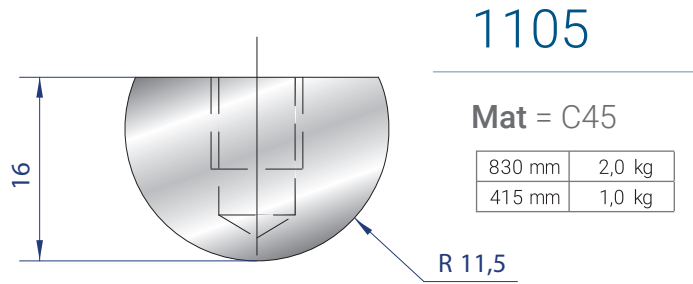

DISPONIBILE ANCHE NELLA VERSIONE NITRURATA
AVAILABLE ALSO IN THE VERSION NITRIDED

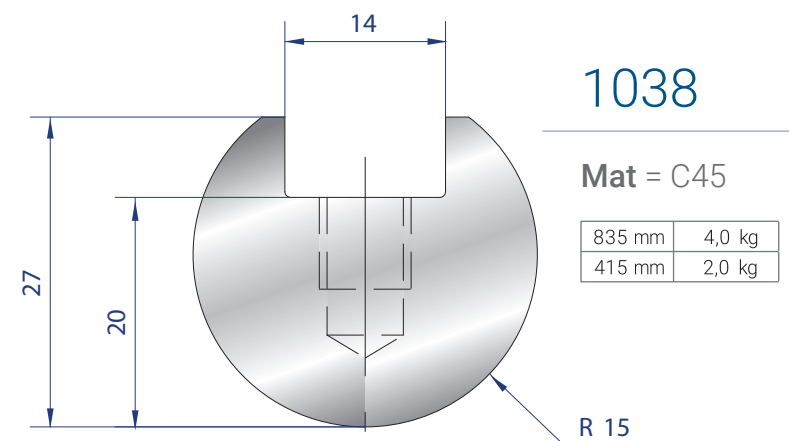
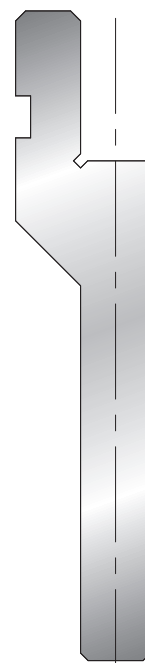
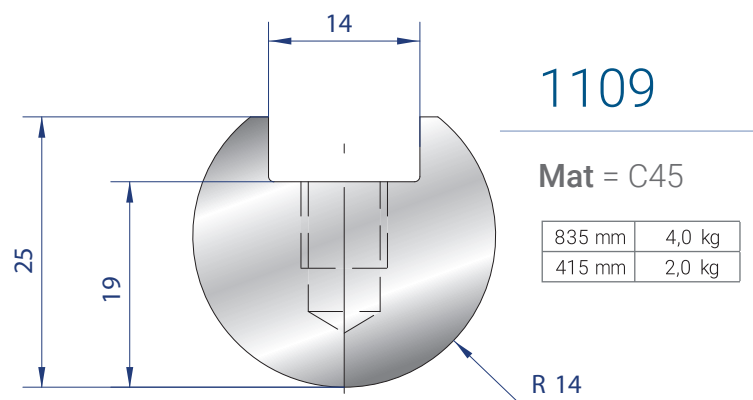

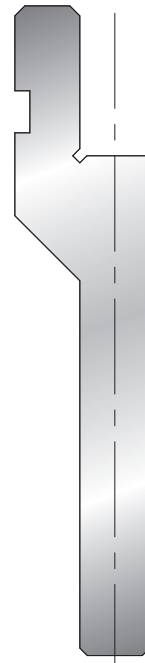
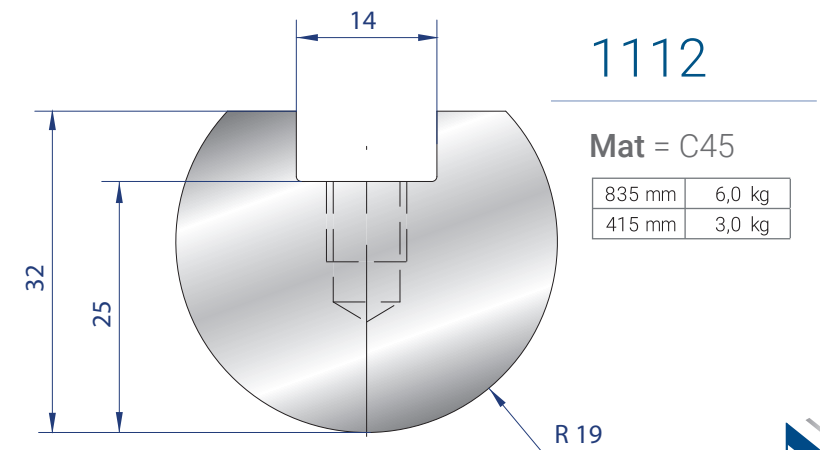
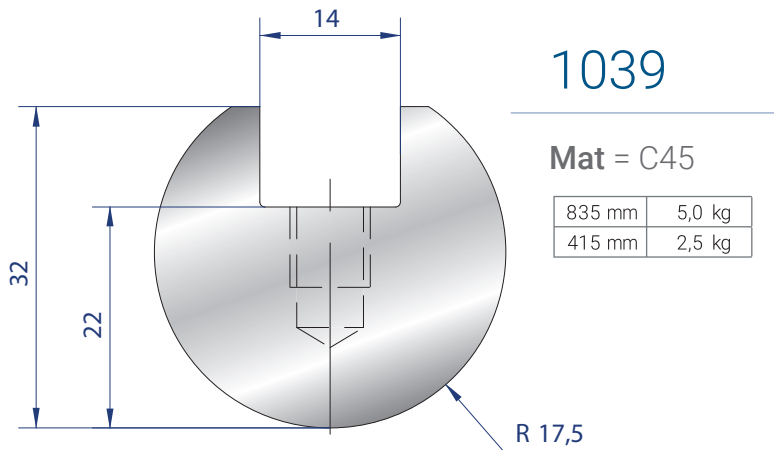
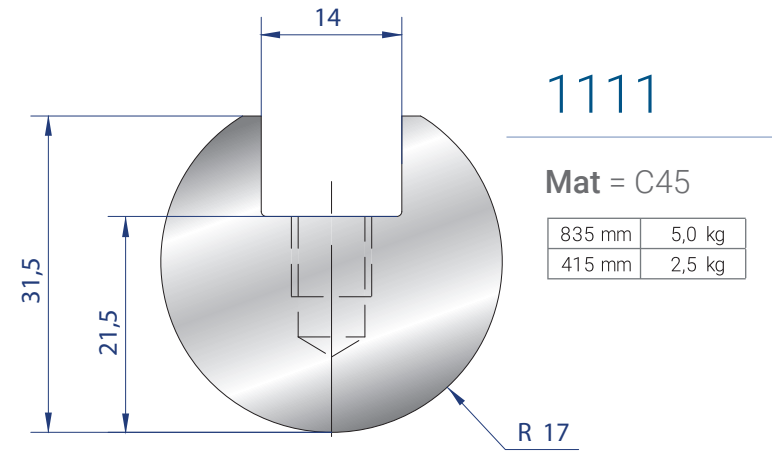
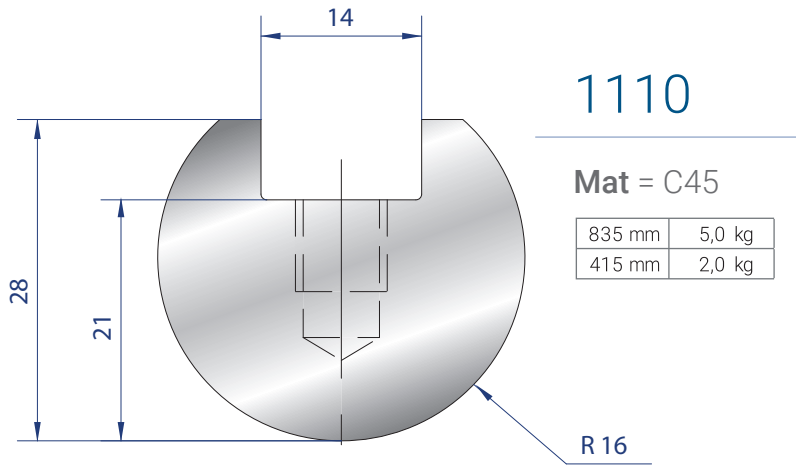

DISPONIBILE ANCHE NELLA VERSIONE NITRURATA
AVAILABLE ALSO IN THE VERSION NITRIDED

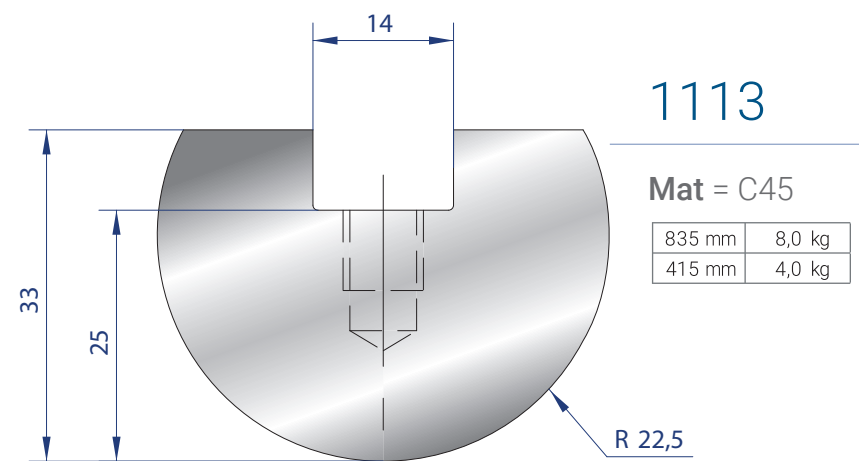
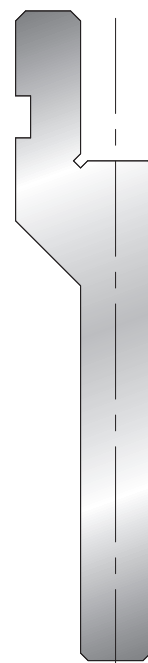
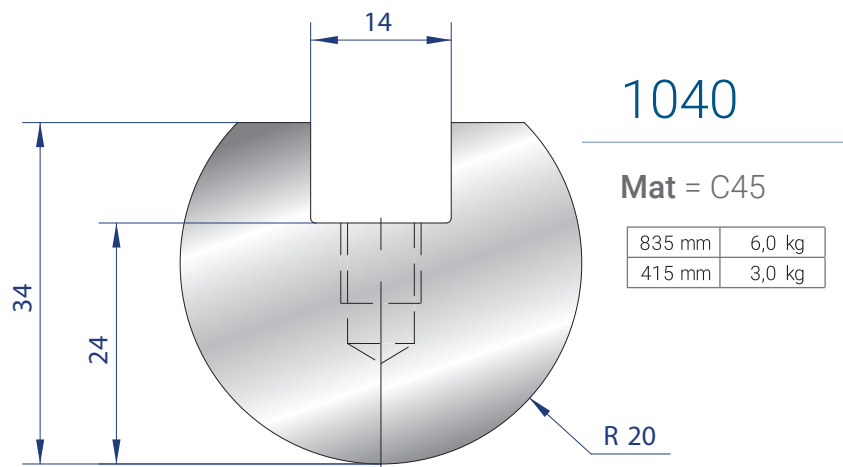

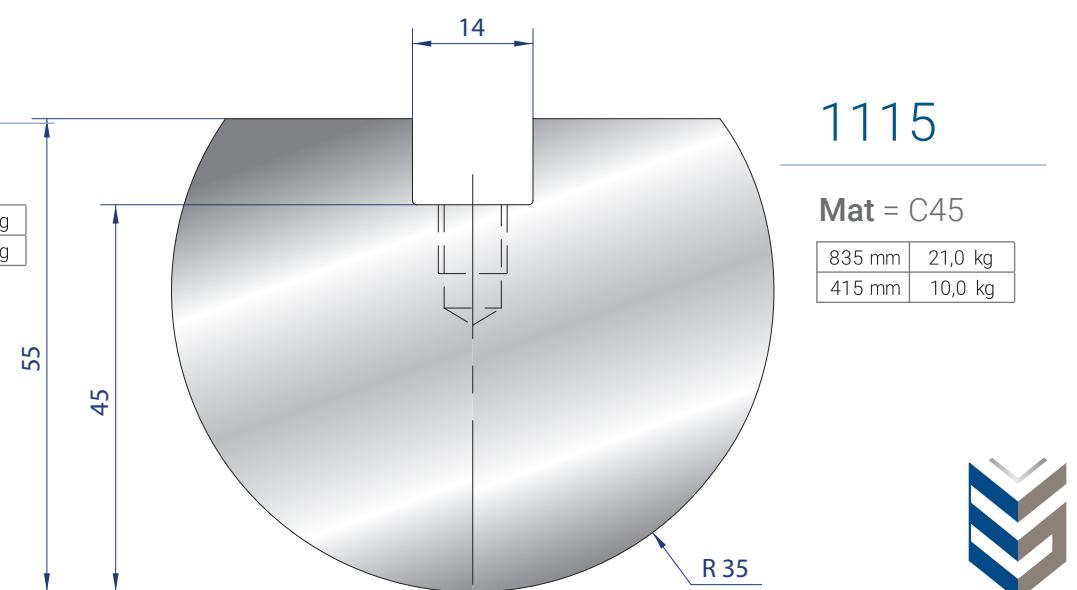
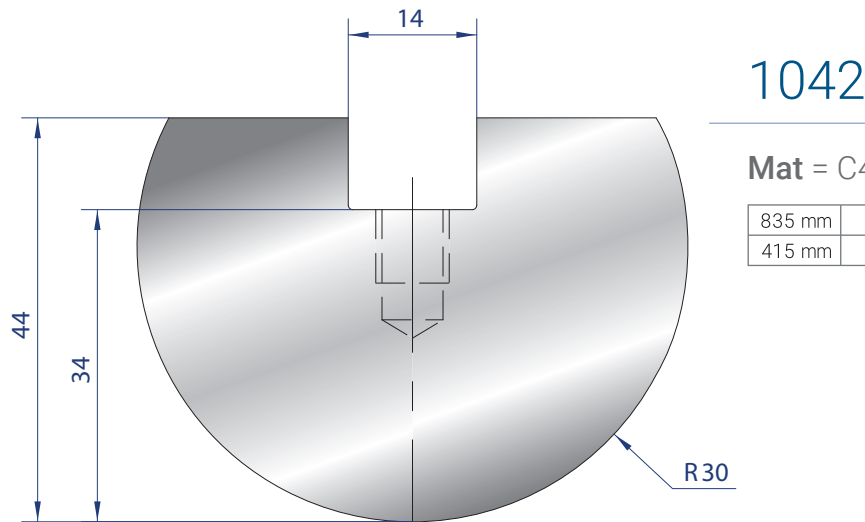
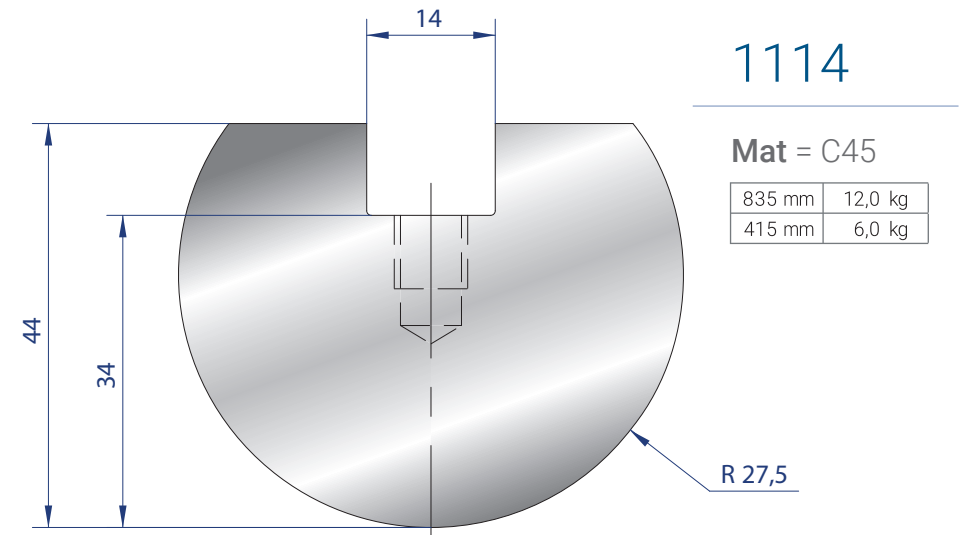
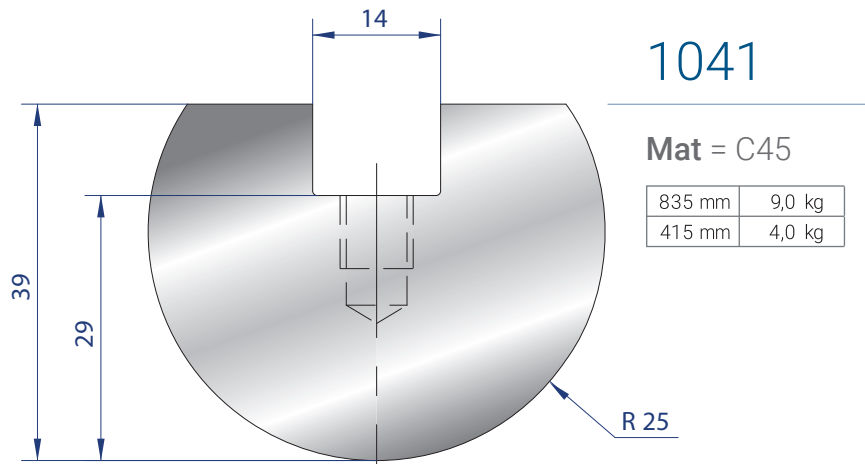

ELEMENTI RAGGIATI / RADIUS TOOLS

DISPONIBILE ANCHE NELLA VERSIONE NITRURATA

AVAILABLE ALSO IN THE VERSION NITRIDED

1116

Mat = C45

835 mm	24,0 kg
415 mm	12,0 kg

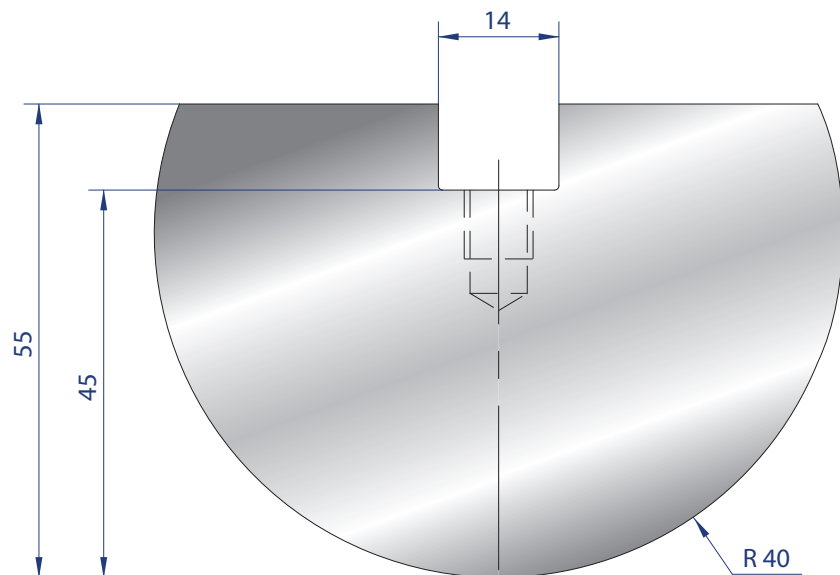

1117

Mat = C45

835 mm	29,0 kg
415 mm	14,0 kg

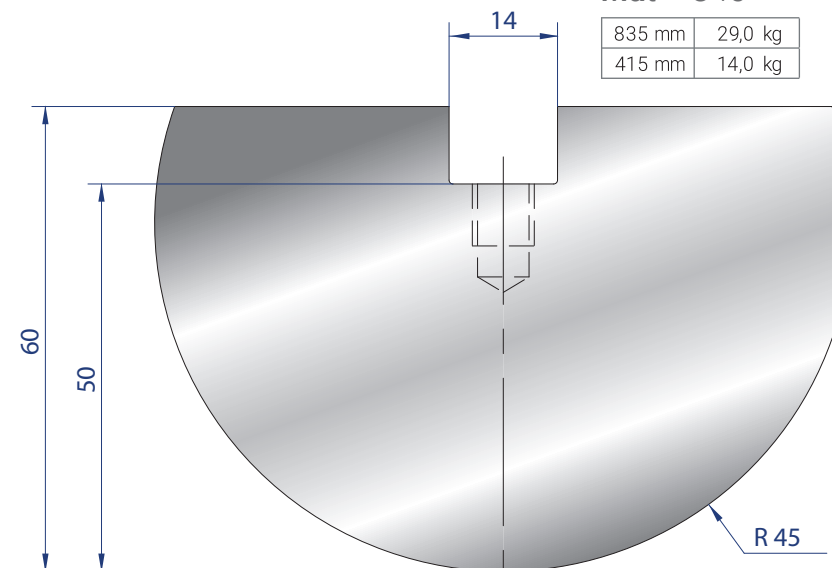

1118

Mat = C45

835 mm	34,0 kg
415 mm	17,0 kg

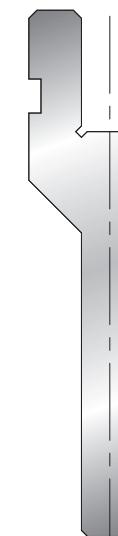
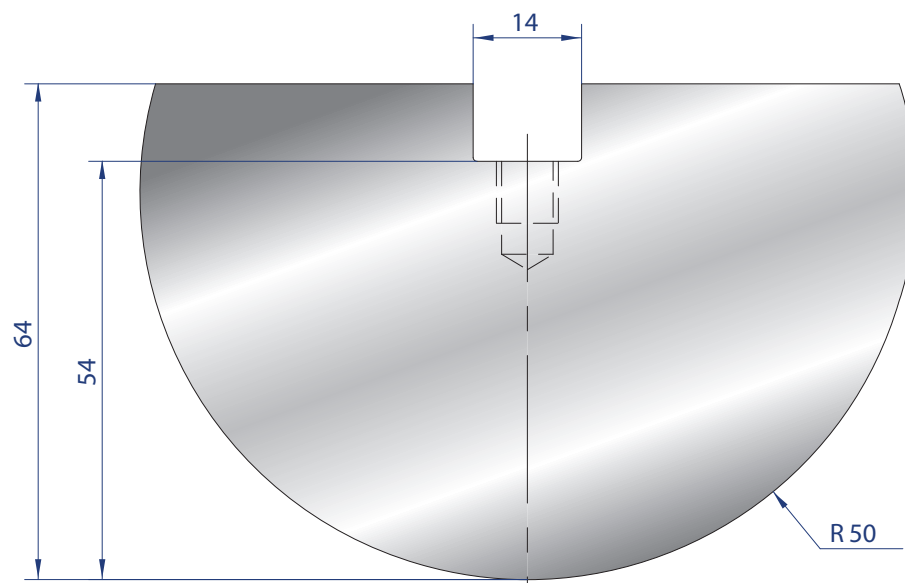

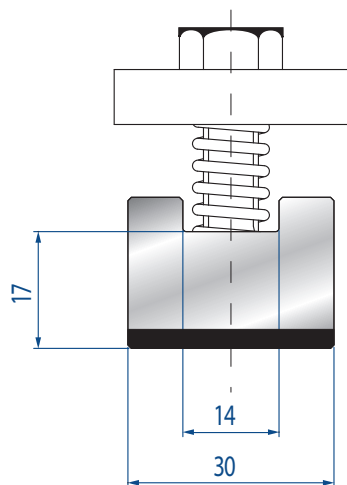

1043

Mat = C45

835 mm	3,0 kg
415 mm	1,0 kg

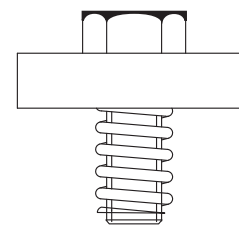
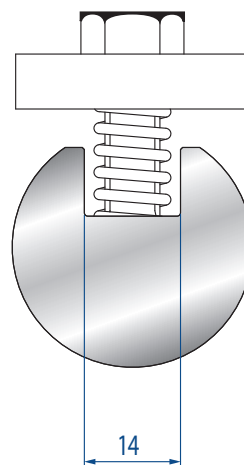

4274

Mat = C45

MOLLA + VITE + PIASTRINA
SPRING + SCREW + PLATE

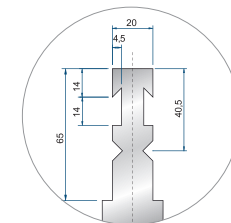

Attacco RF-A incluso
su richiesta
RF-A tang included
on demand

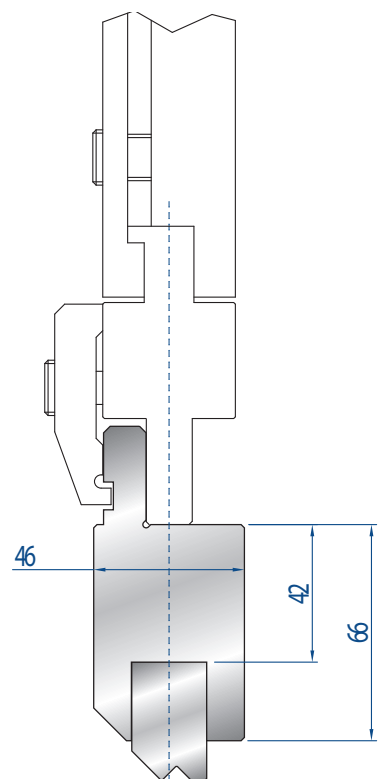

1150

Amada/Promecam
Mat = C45

835 mm	38,0 kg
415 mm	19,0 kg

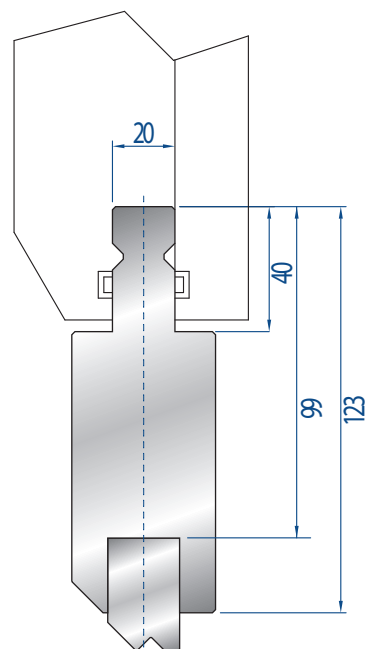
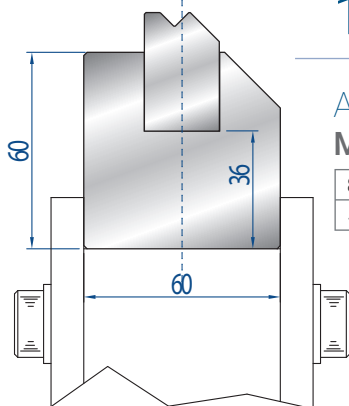

1242

Trumpf/ Wila
Mat = C45

835 mm	50,0 kg
415 mm	25,0 kg

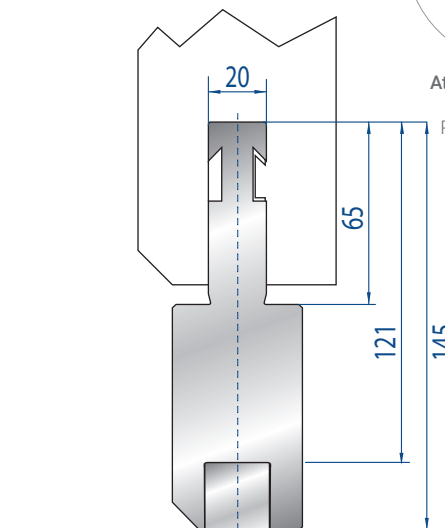
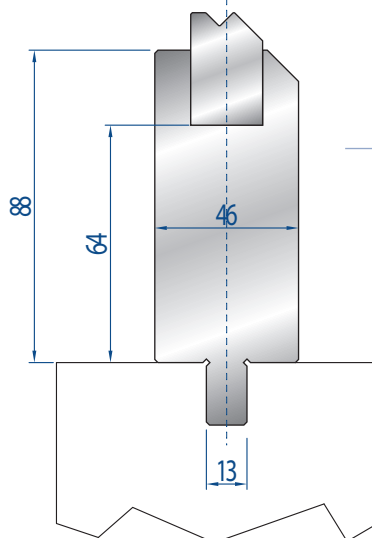

1198

Bystronic
Mat = C45

835 mm	51,7 kg
415 mm	25,7 kg

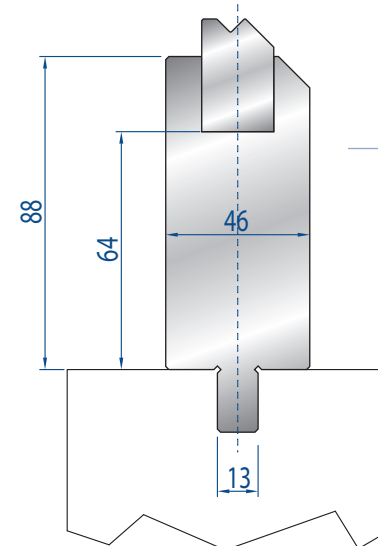

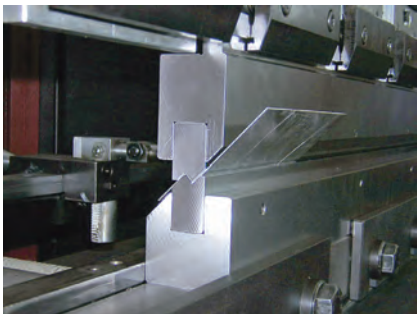
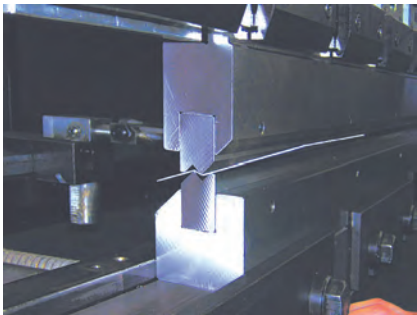
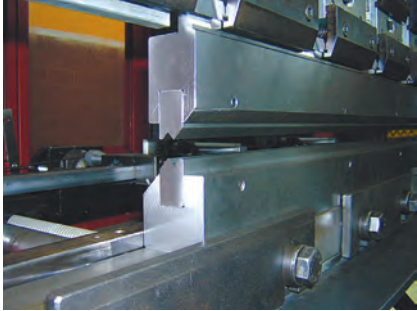

CODE	Z	GRADI DEGREES	SPESSORE MAX. LAMIERA MAX SHEET THICKNESS
1130	1	160°	0,5 mm
1276	1	90°	0,5 mm
1131	1,5	160°	0,6 mm
1277	1,5	90°	0,6 mm
1132	2	150°	0,8 mm
1274	2	90°	0,8 mm
1133	2,5	140°	1,0 mm
1275	2,5	90°	1,0 mm
1134	3	90°	1,0 mm
1135	3,5	90°	1,2 mm
1136	4	90°	1,2 mm
1137	4,5	90°	1,5 mm
1138	5	90°	1,5 mm
1139	5,5	90°	1,5 mm
1140	6	90°	1,5 mm
1141	6,5	90°	1,5 mm
1142	7	90°	2,0 mm
1143	7,5	90°	2,0 mm
1144	8	90°	2,5 mm
1145	9	90°	2,5 mm
1146	10	90°	3,0 mm
1147	11	90°	3,0 mm
1148	12	90°	3,0 mm
1278	13	90°	3,0 mm
1279	14	90°	3,0 mm
1280	15	90°	3,0 mm



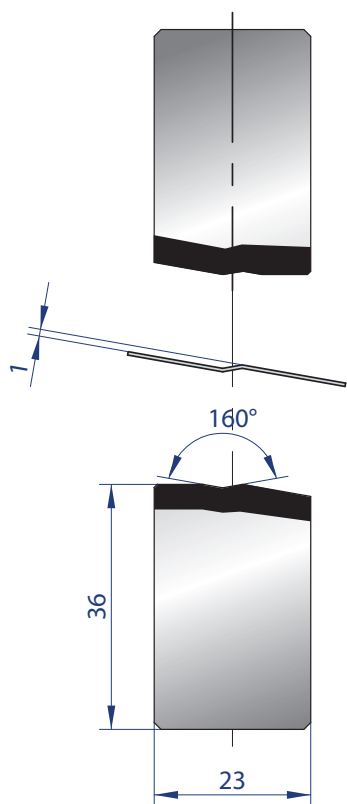

1130

160°
Mat = C45

835 mm	10,0 kg
415 mm	5,0 kg

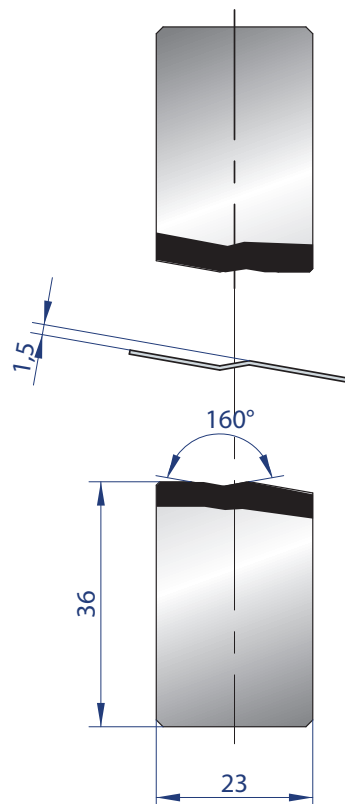

1131

160°
Mat = C45

835 mm	10,0 kg
415 mm	5,0 kg

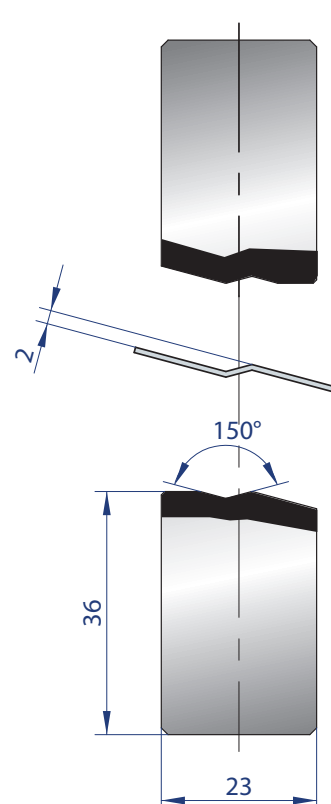

1132

150°
Mat = C45

835 mm	10,0 kg
415 mm	5,0 kg

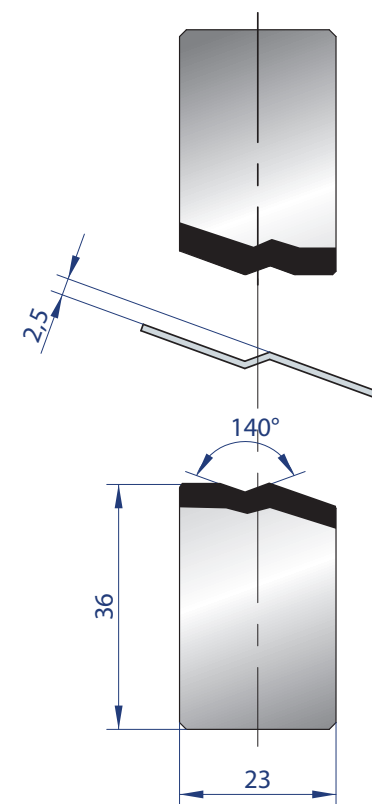

1133

140°
Mat = C45

835 mm	10,0 kg
415 mm	5,0 kg

PER VERIFICARE LA FATTIBILITÀ DELLA PIEGA IN BASE ALLO SPESSORE LAMIERA, VEDI TABELLA PAGINA 24
TO CHOOSE THE RIGHT JOGGLE TOOL BASED ON THE SHEET THICKNESS, PLEASE SEE THE CHART ON PAGE 24

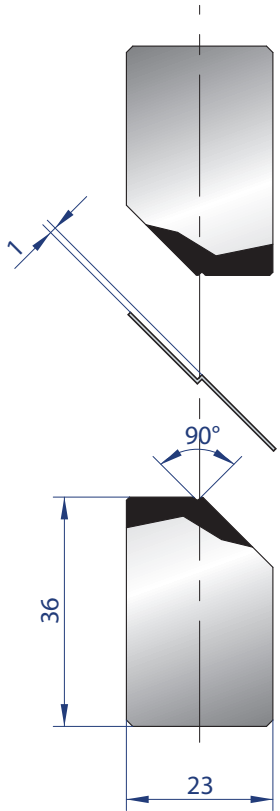

1276

90°
Mat = C45

835 mm	10,0 kg
415 mm	5,0 kg

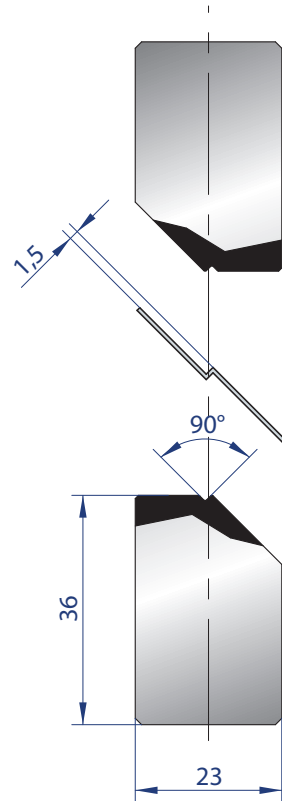

1277

90°
Mat = C45

835 mm	10,0 kg
415 mm	5,0 kg

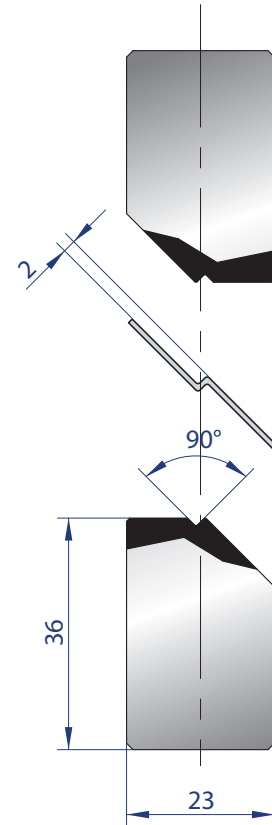

1274

90°
Mat = C45

835 mm	10,0 kg
415 mm	5,0 kg

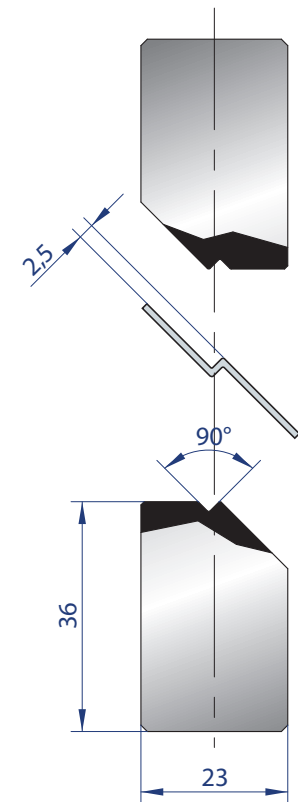

1275

90°
Mat = C45

835 mm	10,0 kg
415 mm	5,0 kg



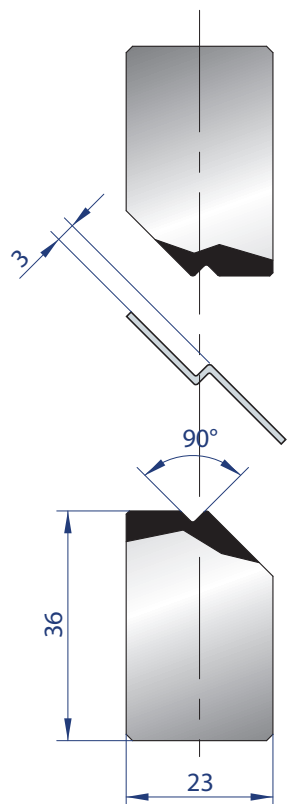

1134

90°
Mat = C45

835 mm	10,0 kg
415 mm	5,0 kg

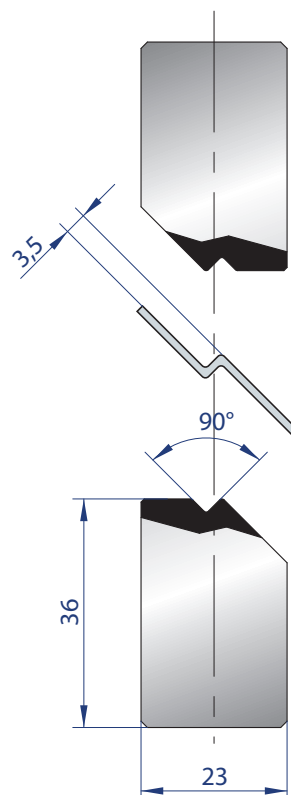

1135

90°
Mat = C45

835 mm	10,0 kg
415 mm	5,0 kg

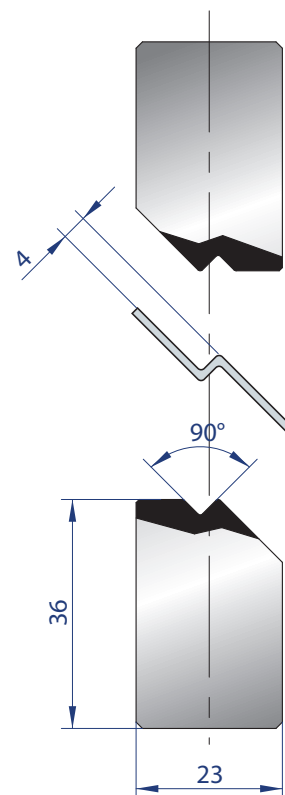

1136

90°
Mat = C45

835 mm	10,0 kg
415 mm	5,0 kg

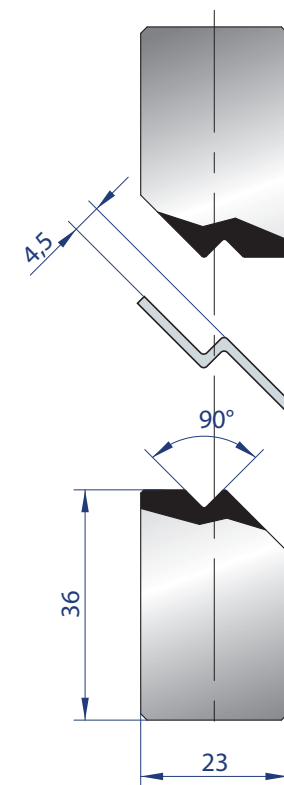

1137

90°
Mat = C45

835 mm	10,0 kg
415 mm	5,0 kg

PER VERIFICARE LA FATTIBILITÀ DELLA PIEGA IN BASE ALLO SPESSORE LAMIERA, VEDI TABELLA PAGINA 24
TO CHOOSE THE RIGHT JOGGLE TOOL BASED ON THE SHEET THICKNESS, PLEASE SEE THE CHART ON PAGE 24

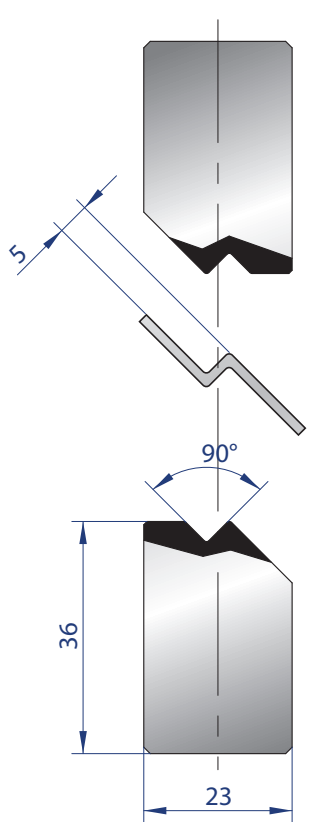

1138

90°
Mat = C45

835 mm	10,0 kg
415 mm	5,0 kg

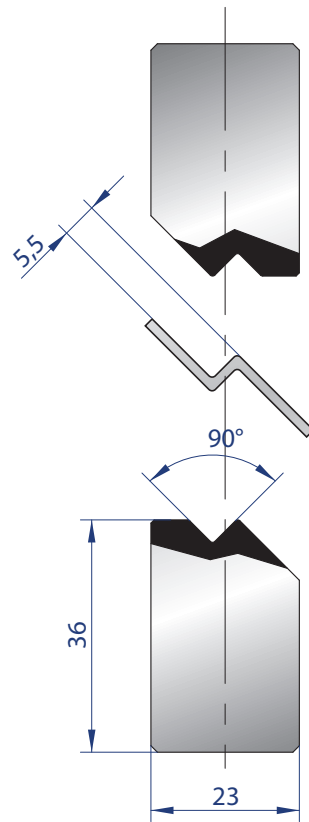

1139

90°
Mat = C45

835 mm	10,0 kg
415 mm	5,0 kg

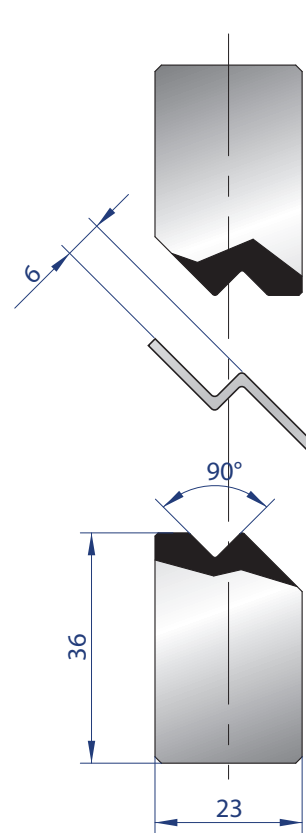

1140

90°
Mat = C45

835 mm	10,0 kg
415 mm	5,0 kg

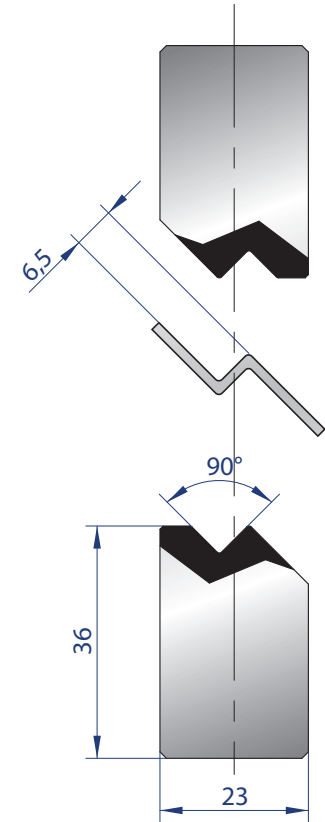

1141

90°
Mat = C45

835 mm	10,0 kg
415 mm	5,0 kg

PER VERIFICARE LA FATTIBILITÀ DELLA PIEGA IN BASE ALLO SPESSORE LAMIERA, VEDI TABELLA PAGINA 24
TO CHOOSE THE RIGHT JOGGLE TOOL BASED ON THE SHEET THICKNESS, PLEASE SEE THE CHART ON PAGE 24



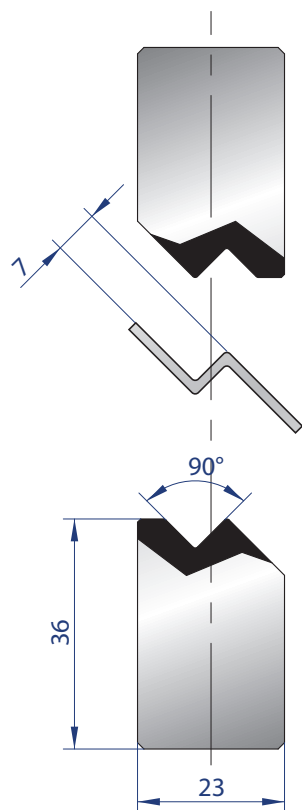

1142

90°
Mat = C45

835 mm	10,0 kg
415 mm	5,0 kg

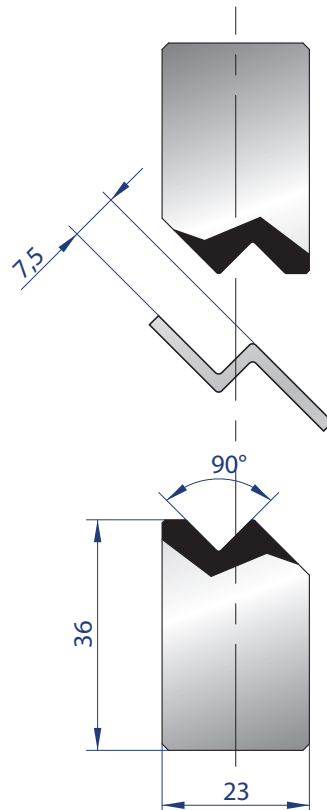

1143

90°
Mat = C45

835 mm	10,0 kg
415 mm	5,0 kg

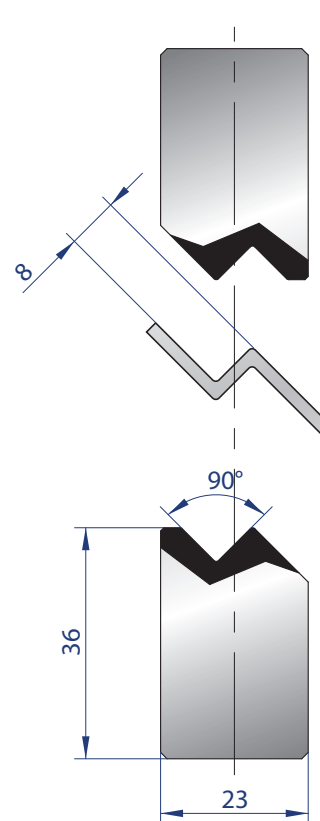

1144

90°
Mat = C45

835 mm	10,0 kg
415 mm	5,0 kg

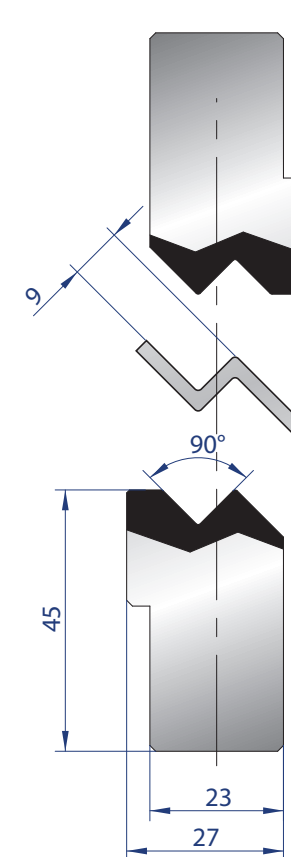

1145

90°
Mat = C45

835 mm	11,0 kg
415 mm	6,0 kg

PER VERIFICARE LA FATTIBILITÀ DELLA PIEGA IN BASE ALLO SPESSORE LAMIERA, VEDI TABELLA PAGINA 24
TO CHOOSE THE RIGHT JOGGLE TOOL BASED ON THE SHEET THICKNESS, PLEASE SEE THE CHART ON PAGE 24

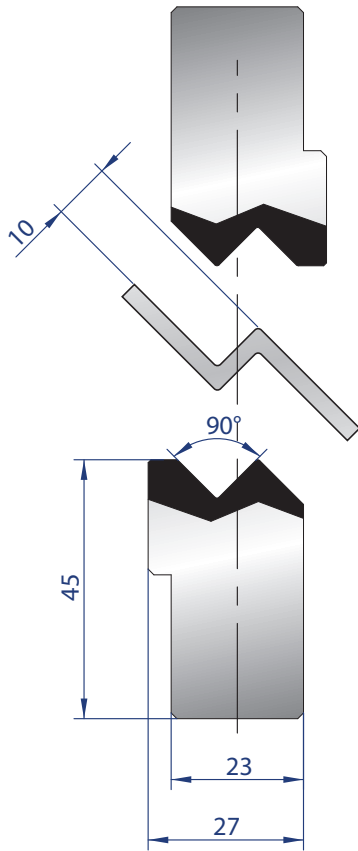

1146

90°
Mat = C45

835 mm	11,0 kg
415 mm	6,0 kg

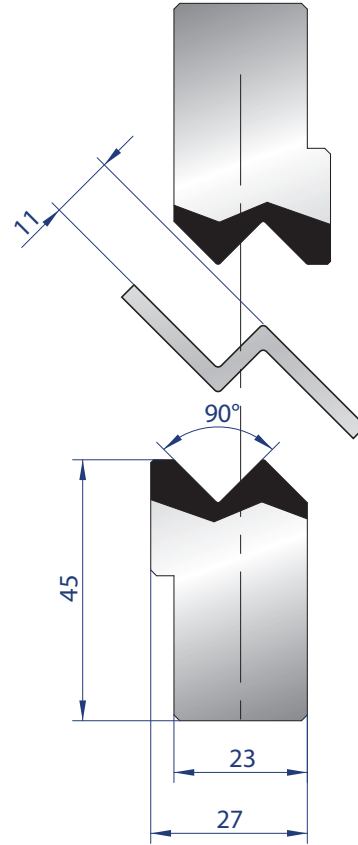

1147

90°
Mat = C45

835 mm	11,0 kg
415 mm	6,0 kg

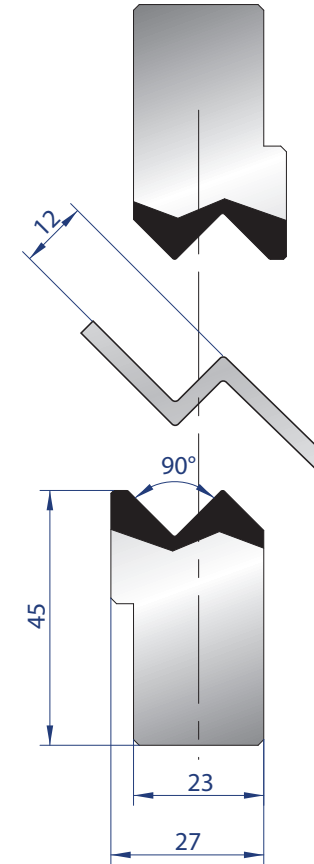

1148

90°
Mat = C45

835 mm	11,0 kg
415 mm	6,0 kg

PER VERIFICARE LA FATTIBILITÀ DELLA PIEGA IN BASE ALLO SPESSORE LAMIERA, VEDI TABELLA PAGINA 24
TO CHOOSE THE RIGHT JOGGLE TOOL BASED ON THE SHEET THICKNESS, PLEASE SEE THE CHART ON PAGE 24



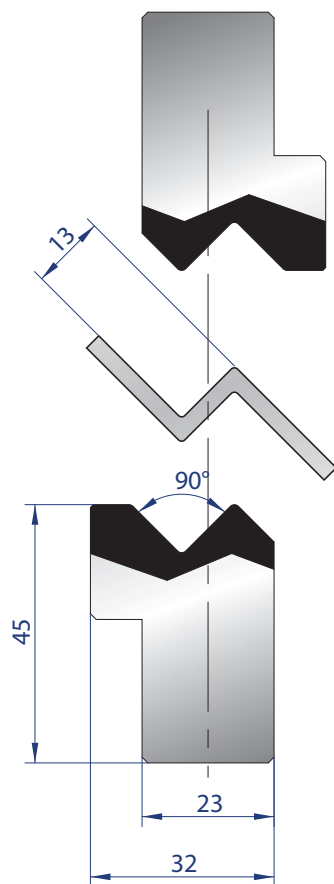

1278

90°
Mat = C45

835 mm	12,0 kg
415 mm	6,0 kg

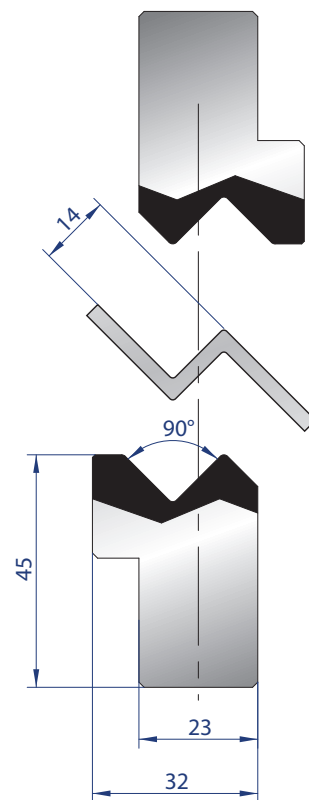

1279

90°
Mat = C45

835 mm	12,0 kg
415 mm	6,0 kg

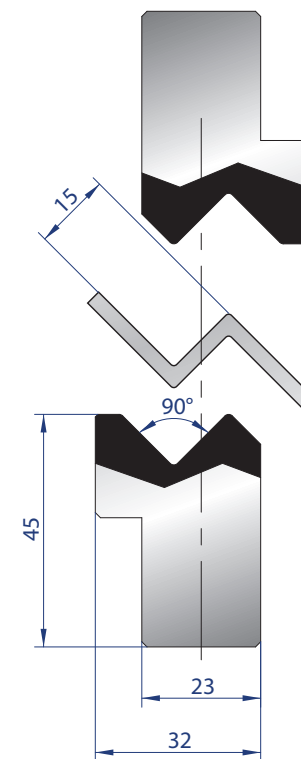

1280

90°
Mat = C45

835 mm	12,0 kg
415 mm	6,0 kg

PER VERIFICARE LA FATTIBILITÀ DELLA PIEGA IN BASE ALLO SPESSORE LAMIERA, VEDI TABELLA PAGINA 24
TO CHOOSE THE RIGHT JOGGLE TOOL BASED ON THE SHEET THICKNESS, PLEASE SEE THE CHART ON PAGE 24

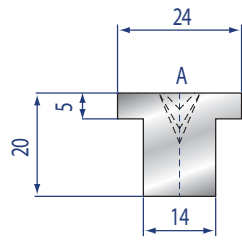

2112

835 mm	0,3 kg
415 mm	0,2 kg

A	V		
88°	6	8	10
60°	6	8	10
45°	6	8	10
30°	6	8	

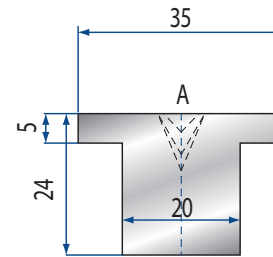

2113

835 mm	0,4 kg
415 mm	0,2 kg

A	V				
88°	6	8	10	12	16
60°	6	8	10	12	16
45°	6	8	10	12	
30°	6	8	10		

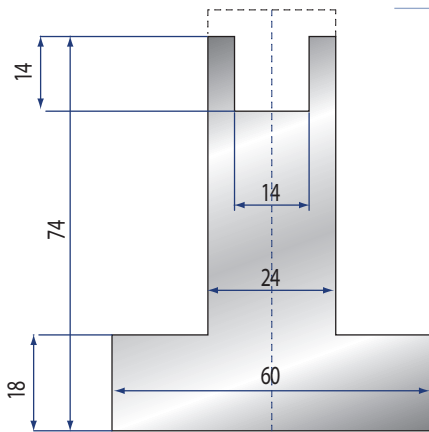

2109

Amada

835 mm	15,0 kg
415 mm	7,0 kg

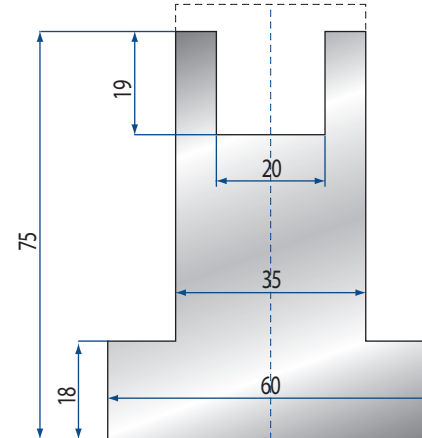

2110

Amada

835 mm	19,0 kg
415 mm	9,0 kg



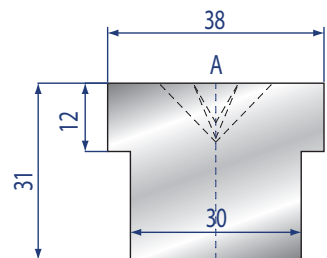

2114

835 mm	0,4 kg
415 mm	0,2 kg

A	V						
88°	6	8	10	12	16	20	25
60°	6	8	10	12	16	20	
45°	6	8	10	12	16	20	
30°	6	8	10	12	16		

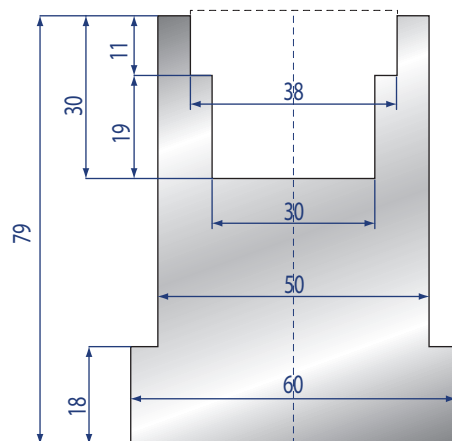

2111

Amada

835 mm	22,0 kg
415 mm	11,0 kg

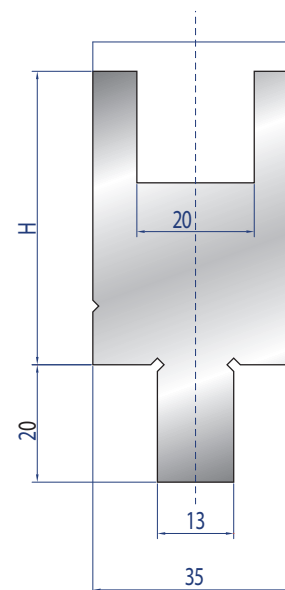

2115

Bystronic / Trumpf / Wila

H = 50

835 mm	11,0 kg
415 mm	5,0 kg

2116

Bystronic / Trumpf / Wila

H = 95

835 mm	19,0 kg
415 mm	9,0 kg

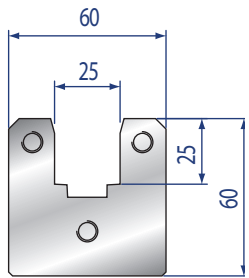

2036

Amada

835 mm	19,0 kg
415 mm	9,0 kg

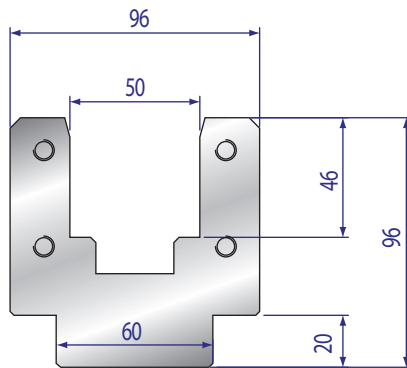

2037

Amada

835 mm	37,0 kg
415 mm	18,0 kg

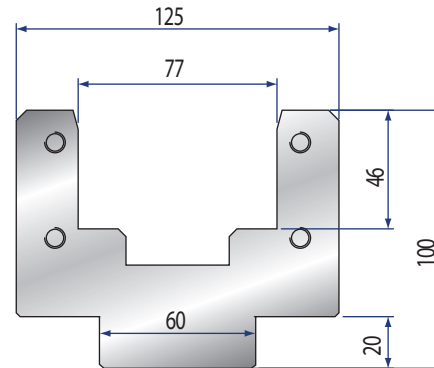

2038

Amada

835 mm	45,0 kg
415 mm	22,0 kg

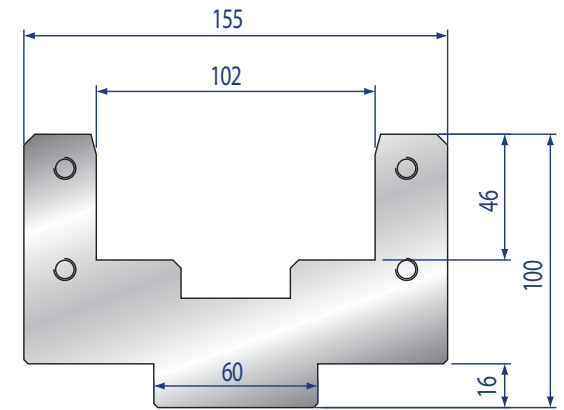

2040

Amada

835 mm	55,0 kg
415 mm	27,0 kg



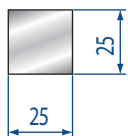

2101

92 Shore

835 mm	0,7 kg
415 mm	0,3 kg

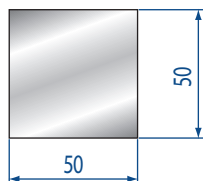

2102

92 Shore

835 mm	2,5 kg
415 mm	1,0 kg

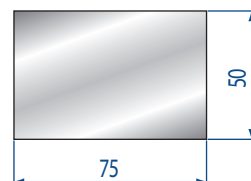

2103

92 Shore

835 mm	3,5 kg
415 mm	1,0 kg

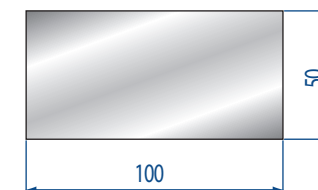

2104

92 Shore

835 mm	5,0 kg
415 mm	2,0 kg

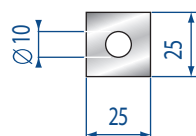

2105

92 Shore

835 mm	0,6 kg
415 mm	0,3 kg

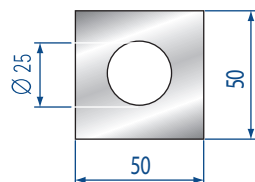

2106

92 Shore

835 mm	2,2 kg
415 mm	1,0 kg

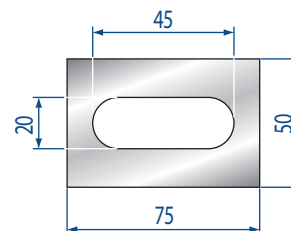

2107

92 Shore

835 mm	3,2 kg
415 mm	1,0 kg

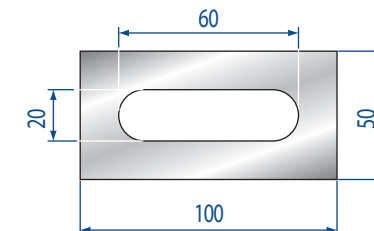

2108

92 Shore

835 mm	4,5 kg
415 mm	2,0 kg

**GAMMA COMPLETA (AUTOMATICA E MANUALE) DI SISTEMI DI STAFFAGGIO UTENSILI
PER RIMOZIONE/INSTALLAZIONE FRONTALE CON ALLINEAMENTO AUTOMATICO**
COMPLETE RANGE (AUTOMATIC AND MANUAL) OF CLAMPING SYSTEM
FOR VERTICAL REMOVAL/INSTALLATION WITH AUTOMATIC ALIGNMENT





SISTEMA DI STAFFAGGIO PNEUMATICO PER UTENSILI SUPERIORI EUROGRIP - MODELLO "P-TOP"
PNEUMATIC UPPER TOOL CLAMPING SYSTEM EUROGRIP – MODEL "P-TOP"

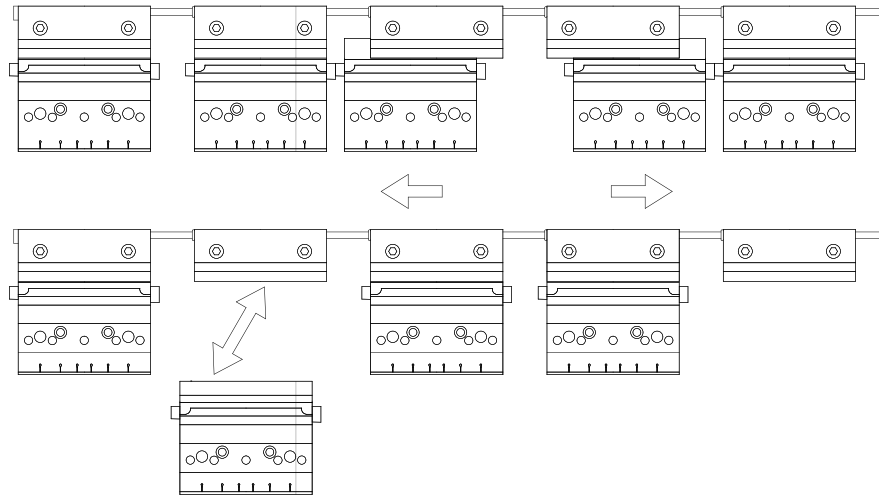

4391

Peso / weight = 6,2 kg

Sistema di staffaggio pneumatico superiore
composto da:

- Intermediari speciali L=150mm H100mm; asse di piegatura a 7mm.
- Staffa pneumatica con sistema anticaduta per inserimento/rimozione verticale da fronte macchina ed allineamento degli utensili in fase di chiusura della staffa.
- Staffa pneumatica per tavola superiore che gestisce il flusso pneumatico e permette gli eventuali spostamenti e rimozioni degli intermediari.

Upper pneumatic clamping system made up of:

- Special intermediate L=150mm H100mm; bending axis at 7mm.
- Pneumatic safety clamp, it allows the tooling vertical removal/ insertion from the machine front and the tool alignment during the clamping phase.
- Pneumatic safety clamp for mounting the intermediate on the upper machine beam, it manages the pneumatic flow and allows the free intermediates removal and displacement.



Per utilizzare il sistema EUROGRIP P è necessaria la fornitura di componenti pneumatici (che verranno selezionati al momento dell'offerta)

The EUROGRIP SYSTEM needs, for being utilized, the supply of some pneumatic components (that will be selected at offer time)



SISTEMA DI STAFFAGGIO PNEUMATICO PER UTENSILI SUPERIORI EUROGRIP - MODELLO "P-EASY"
PNEUMATIC UPPER TOOL CLAMPING SYSTEM EUROGRIP – MODEL "P-EASY"

4392

Peso / weight = 5,2 kg

Sistema di staffaggio pneumatico superiore
composto da:

- Intermediari speciali L=150mm H100mm; asse di piegatura a 7mm.
- Staffa pneumatica con sistema anticaduta per inserimento/rimozione verticale da fronte macchina ed allineamento degli utensili in fase di chiusura della staffa.
- Ogni intermediario viene montato sulla tavola superiore tramite le staffe originali della macchina il flusso pneumatico viene gestito tramite tubi flessibili che ne permettono lo spostamento e la rimozione.

Upper pneumatic clamping system made up of:

- Special intermediates L=150mm H100mm; bending axis at 7mm.
- Pneumatic safety clamp, it allows the tooling vertical removal/insertion from the machine front and the tool alignment during the clamping phase.
- Each intermediate mounts to the upper beam through the original machine clamp. The pneumatic flow is managed through flexible pipes that allows the intermediates removal and displacement.

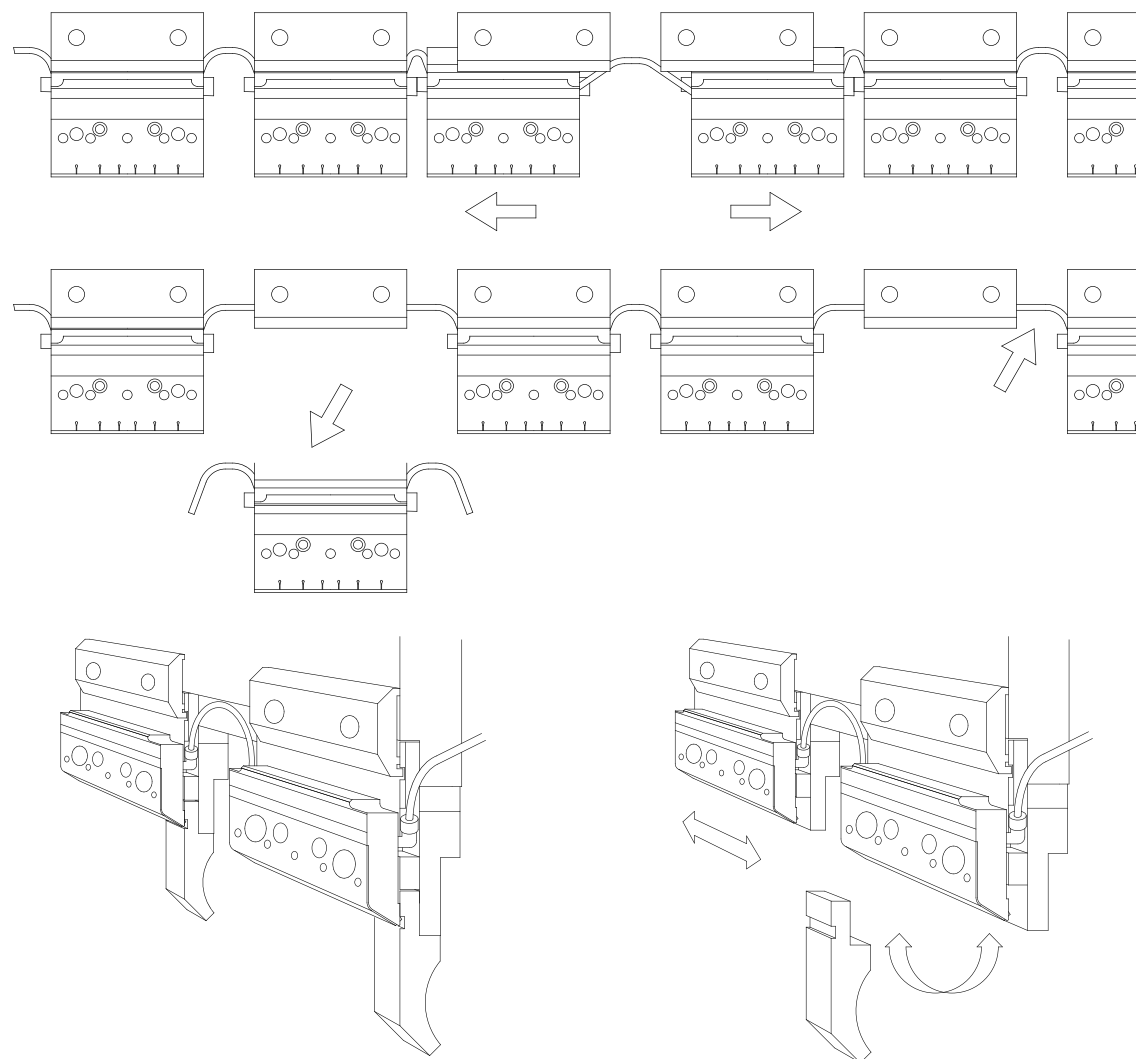

Per utilizzare il sistema EUROGRIP P è necessaria la fornitura di componenti pneumatici (che verranno selezionati al momento dell'offerta)

The EUROGRIP SYSTEM needs, for being utilized, the supply of some pneumatic components (that will be selected at offer time)

SISTEMA DI STAFFAGGIO PNEUMATICO PER UTENSILI INFERIORI EUROGRIP- MODELLO "P-DHOLD"
PNEUMATIC LOWER TOOL CLAMPING SYSTEM EUROGRIP – MODEL "P-DHOLD"

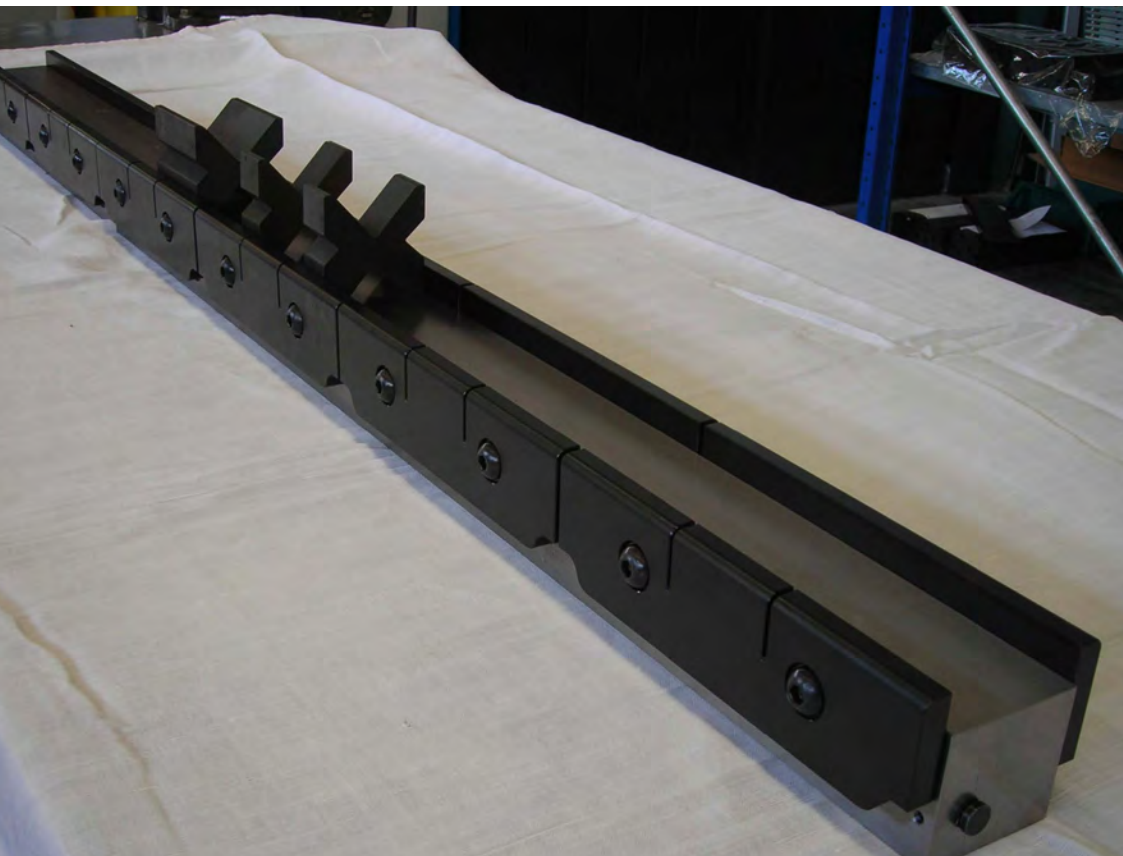

4394

835 mm	27,8 kg
415 mm	13,8 kg
625 mm	20,8 kg

Sistema di staffaggio pneumatico inferiore ad alta velocità composto da unità di bloccaggio inferiori ad azionamento pneumatico che gestiscono l'apertura e la chiusura istantanea e contemporanea di tutte le staffe inferiori della macchina. Il flusso pneumatico transita attraverso le unità per evitare interferenze in fase di piega.

Ogni unità è alta 55mm e Lunga 835mm oppure 415mm spostamenti e rimozioni degli intermediari intermediates removal and displacement.

High speed lower pneumatic clamping system made up of more lower units operated pneumatically that open and close instantaneously all of the lower clamps. The pneumatic flow is driven through the units body in order to avoid any interference during the bending phase.

Each unit is 55mm high and 835 or 415mm long.

Per utilizzare il sistema EUROGRIP P è necessaria la fornitura di componenti pneumatici (che verranno selezionati al momento dell'offerta)

The EUROGRIP SYSTEM needs, for being utilized, the supply of some pneumatic components (that will be selected at offer time)



SISTEMA DI STAFFAGGIO MANUALE PER UTENSILI SUPERIORI EUROGRIP - MODELLO "M-TOP"
MANUAL UPPER TOOL CLAMPING SYSTEM EUROGRIP – MODEL "M-TOP"

4390

Peso / weight = 5,2 kg

Sistema manuale di staffaggio superiore composto da:

- Intermediari speciali L=150mm H100mm; asse di piegatura a 7mm.
- Staffa manuale con sistema anticaduta e leva di comando a scomparsa per inserimento/rimozione verticale da fronte macchina ed allineamento degli utensili in fase di chiusura della staffa.
- Ogni intermediario viene montato sulla tavola superiore tramite la staffa originale della macchina.

Manual upper clamping system made up of:

- Special intermediates L=150mm H100mm; bending axis at 7mm.
- Manual safety clamp featured with an horizontal handle, it allows the tooling vertical removal/insertion from the machine front and the tool alignment during the clamping phase.
- Each intermediate mounts to the upper beam through the original machine clamp.



SISTEMA DI STAFFAGGIO MANUALE PER UTENSILI SUPERIORI EUROGRIP – STAFFA PER RETROFIT MODELLO “M-EASY”
MANUAL UPPER TOOL CLAMPING SYSTEM EUROGRIP – RETROFIT CLAMP MODEL “M-EASY”

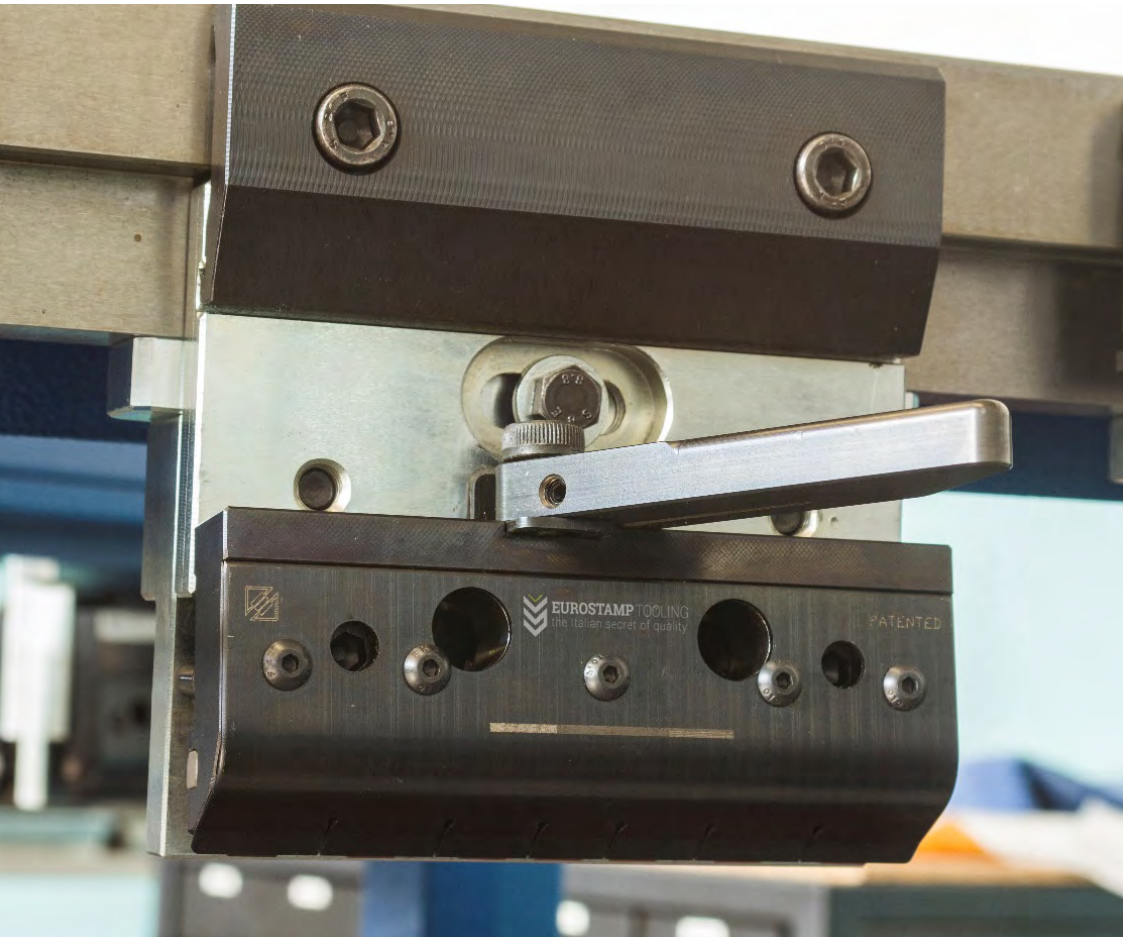

4389

Peso / weight = 0,8 kg

EUROGRIP M-EASY è la più intelligente soluzione per velocizzare e semplificare le operazioni di cambio utensili con il minimo investimento: sostituisce la staffa originale perché è adatta agli intermediari esistenti con le dimensioni L=150mm; H=100mm e asse di piegatura a 7mm.

La staffa di sicurezza M-EASY viene operata tramite una leva a scomparsa, permette l'inserimento/rimozione verticale da fronte macchina e, in fase di bloccaggio, solleva l'utensile per allinearlo.

EUROGRIP M-EASY is the most clever solution for speeding up and simplifying the upper tooling replacement operation with the minimum investment: it replaces the original clamp as it fits on the existing intermediates with dimension width 150mm; height 100mm; bending axis at 7mm.

The M-EASY safety clamp is operated by a horizontal handle, it allows the tooling vertical removal/insertion from the machine front and the tool alignment during the clamping phase.



SISTEMA DI STAFFAGGIO MANUALE PER UTENSILI SUPERIORI EUROGRIP – ADATTATORE MODELLO “M-WDP” MANUAL UPPER TOOL CLAMPING SYSTEM EUROGRIP – ADAPTER MODEL “M-WDP”

4393

Peso / weight = 6,7 kg

EUROGRIP M-WDP è un adattatore che permette di montare utensili superiori in stile Wila su macchine equipaggiate con il sistema Amada/ Promecam. Se gli utensili sono dotati di pulsante di sicurezza potranno venire inseriti e rimossi verticalmente da fronte macchina in totale sicurezza.

La staffa anteriore dell'adattatore è gestita tramite la leva a scomparsa e in fase di chiusura gli utensili vengono sollevati ed allineati.

Le dimensioni dell'adattatore sono L=150mm; H=100mm e asse di piegatura nella parte superiore a 7mm. L'adattatore è disponibile sia nella versione con o senza cunei di centinatura.

EUROGRIP M-WDP is an upper adapter able to allow the installation of Wila style upper tooling on machines equipped with the Amada/ Promecam clamping system. All of the Wila style tooling, when equipped with safety button, could be inserted/removed vertically from the machine front in full safe conditions.

The adapter front clamp is operated by a horizontal handle; during the clamping phase the clamp lifts up and aligns the tooling.

The adapter is 150mm wide and 100 high; the bending axis on the top side is at 7mm. This adapter is available with and without the crowning wedge.



ADATTATORI GENERICI PER UTENSILI SUPERIORI AMADA-PROMECAM
AMADA-PROMECAM GENERIC UPPER TOOL ADAPTERS

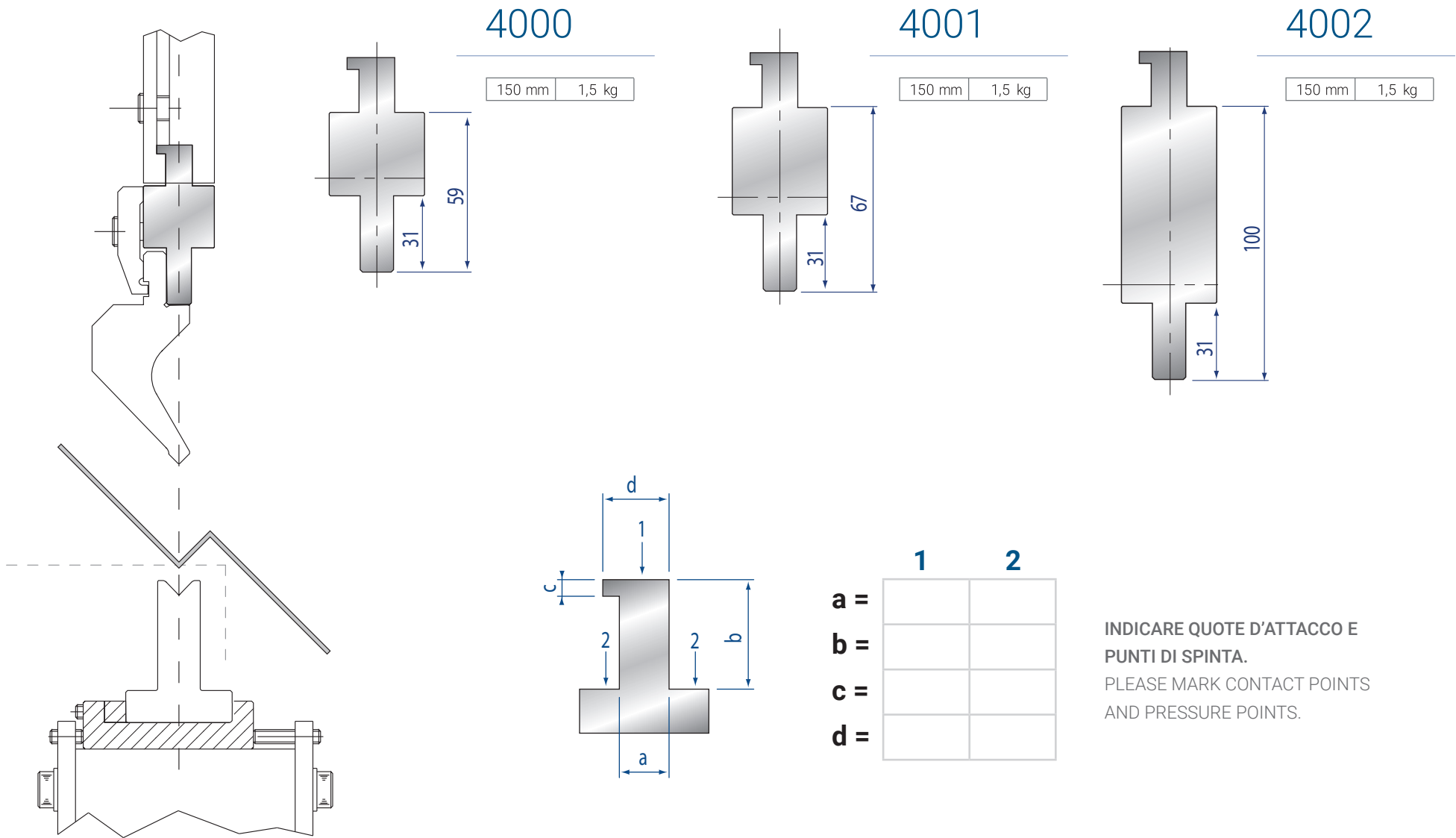

	1	2
a =		
b =		
c =		
d =		

INDICARE QUOTE D'ATTACCO E
PUNTI DI SPINTA.
PLEASE MARK CONTACT POINTS
AND PRESSURE POINTS.

ORDINE MINIMO N. 5 ADATTATORI
MINIMUM ORDER N. 5 ADAPTERS



ADATTATORI INFERIORI PER UTENSILI AMADA-PROMECAM
 AMADA-PROMECAM LOWER TOOL ADAPTERS

ADATTATORE INFERIORE MONOLITICO
 SOLID LOWER ADAPTER

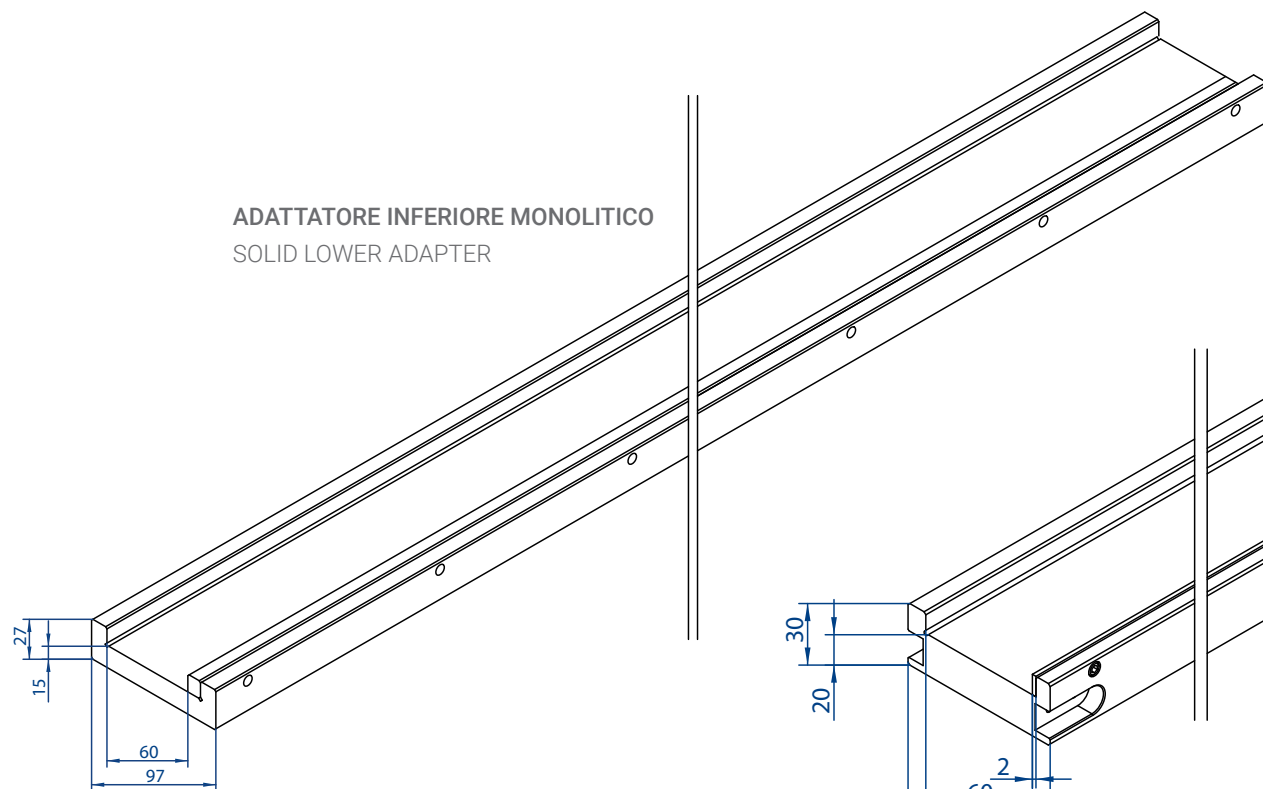

ADATTATORE INFERIORE MODULARE
 MODULAR LOWER ADAPTER

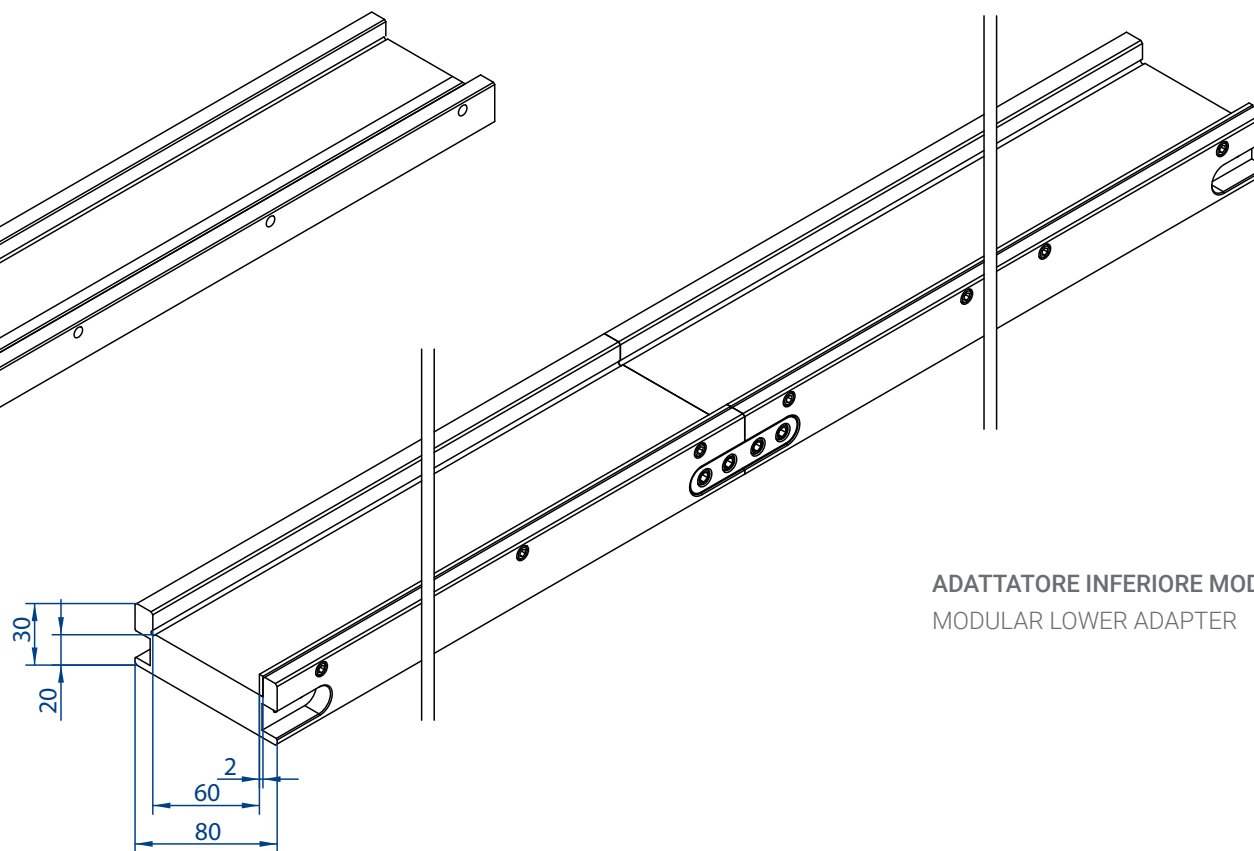

9010

2100 mm | 27,0 kg

9011

2600 mm | 34,0 kg

9012

3100 mm | 40,0 kg

9013

4100 mm | 53,0 kg

9020

1050mm | 14,5 kg

9021

520mm | 7,1 kg

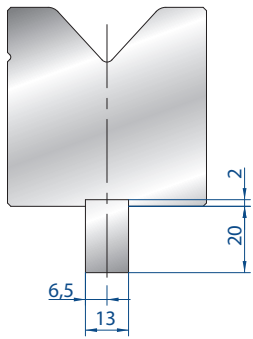

8100

Bystronic /
Trumpf

835 mm	1,8 kg
415 mm	0,9 kg

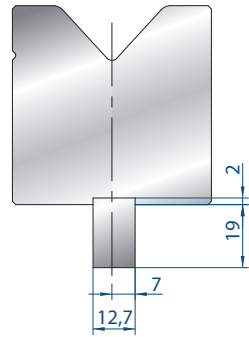

8101

Lvd

835 mm	1,8 kg
415 mm	0,9 kg

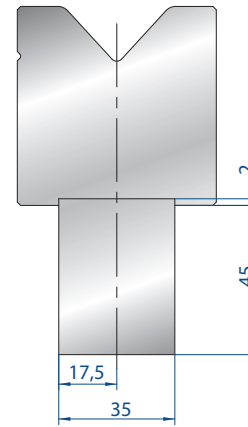

8102

Weinbrenner

835 mm	10,5 kg
415 mm	5,2 kg

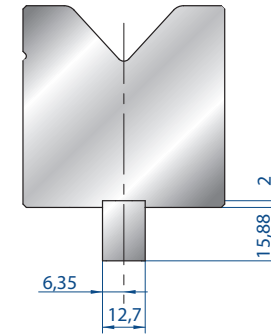

8107

American

835 mm	1,4 kg
415 mm	0,7 kg

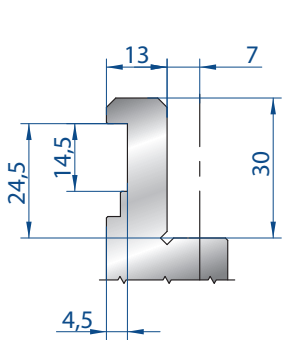

8010

Barretta

835 mm
415 mm
805 mm SEZIONATO

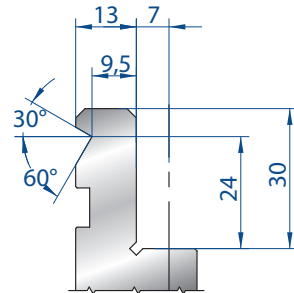

8011

BMB

835 mm
415 mm
805 mm SEZIONATO

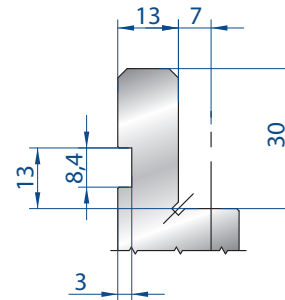

8012

Amada /
Promecam

STANDARD

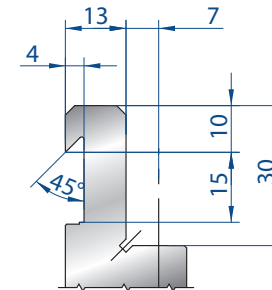

8013

Gasparini

835 mm
415 mm
805 mm SEZIONATO



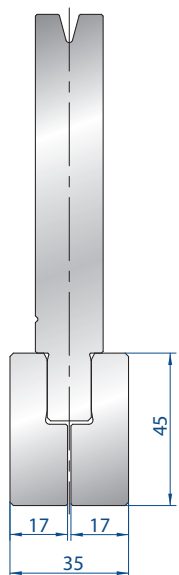

8105

Weinbrenner

1000mm	20,0 kg
500mm	10,0 kg

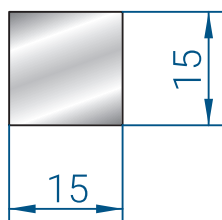

8106

Trafilati 15X15
Square bar 15X15

835 mm	2,9 kg
--------	--------

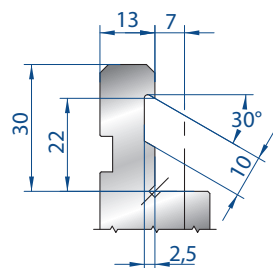

8014

Teda

835 mm
415 mm
805 mm SEZIONATO

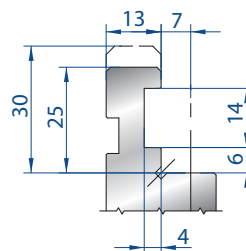

8016

Euro Bystronic

835 mm
415 mm
805 mm SEZIONATO

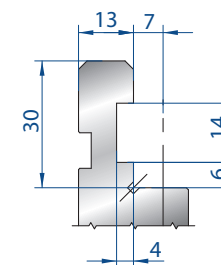

8017

Bystronic

835 mm
415 mm
805 mm SEZIONATO

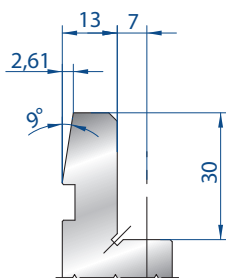

8020

One Touch

835 mm
415 mm
805 mm SEZIONATO

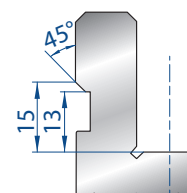

8021

Smart Clamp

835 mm
415 mm
805 mm SEZIONATO

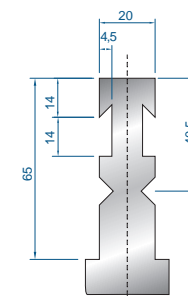

8022

Bystronic RF - A

INCLUDED ON DEMAND

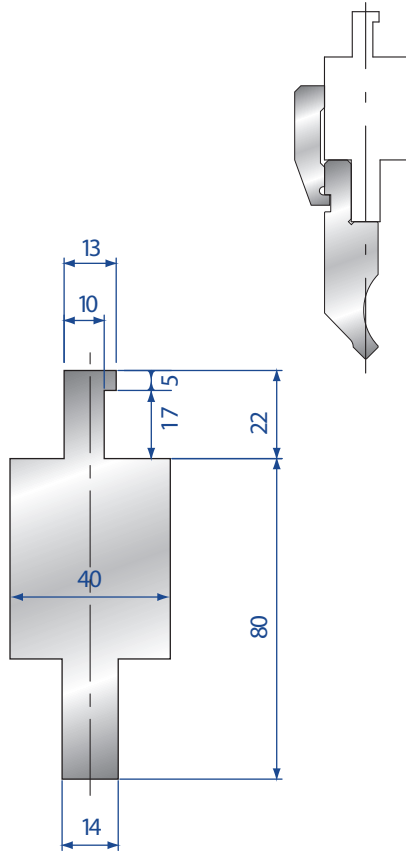

4143

LVD **S**
STANDARD

150 mm 3,0 kg

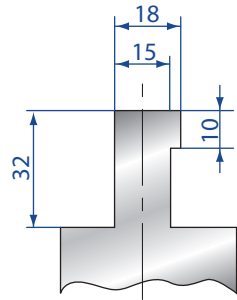

4143

LVD **M** (medium)
SPECIAL

150 mm 3,0 kg

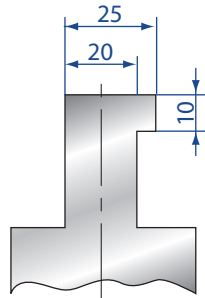

4143

LVD **L** (large)
SPECIAL

150 mm 3,0 kg

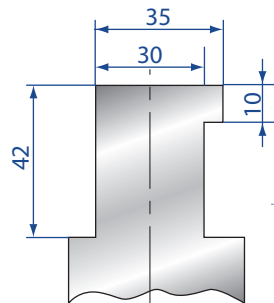

4143

LVD **XL** (extra large)
SPECIAL

150 mm 3,0 kg

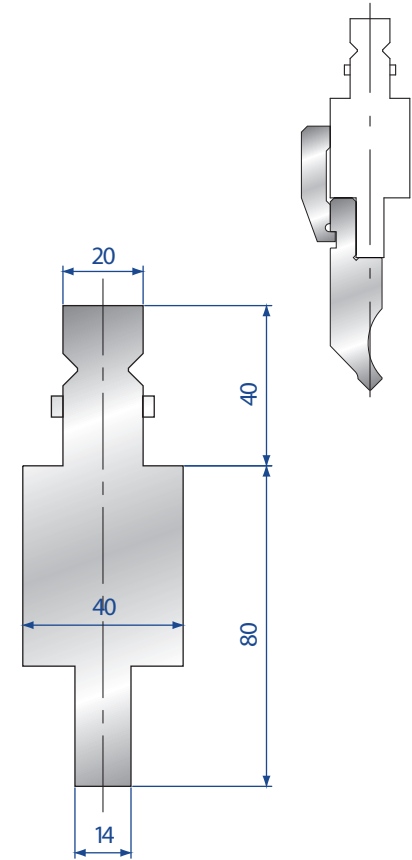

4191

Trumf/Wila

150 mm 4,0 kg



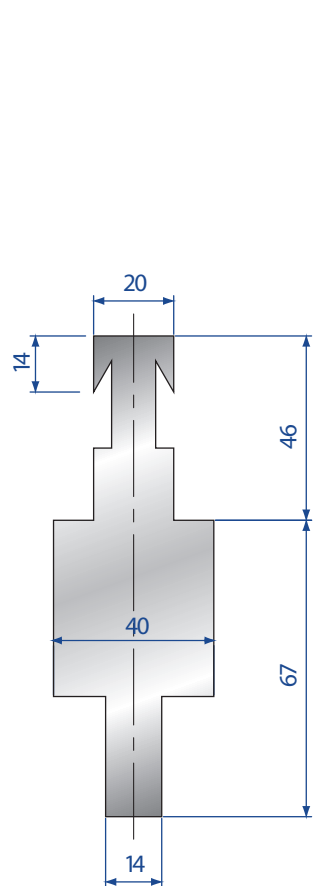

4192

Bystronic - R

150 mm	3,2 kg
--------	--------

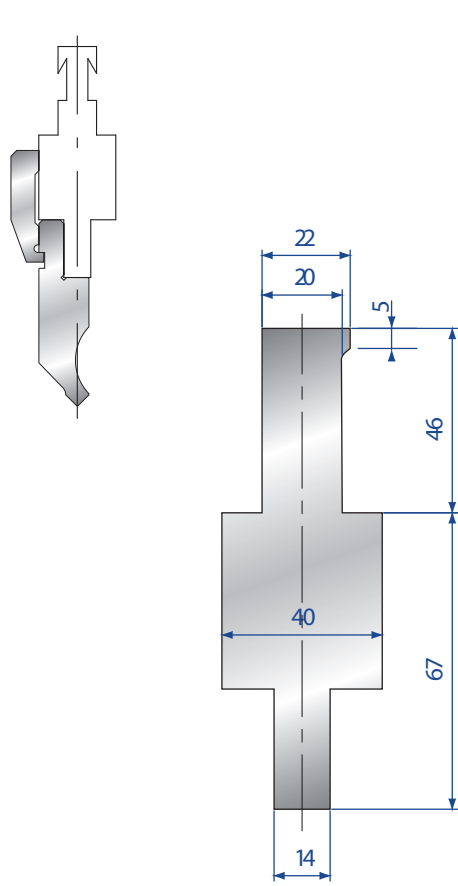

4193

Bystronic - S

150 mm	3,5 kg
--------	--------

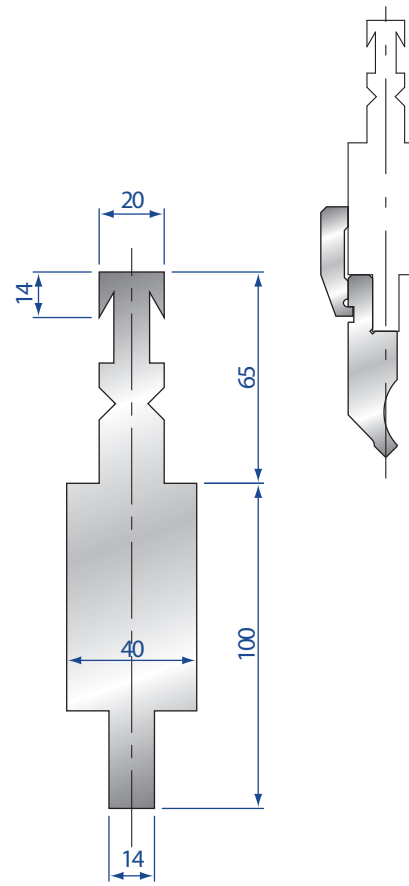

4214

Bystronic - RF-A

150 mm	5,0 kg
--------	--------

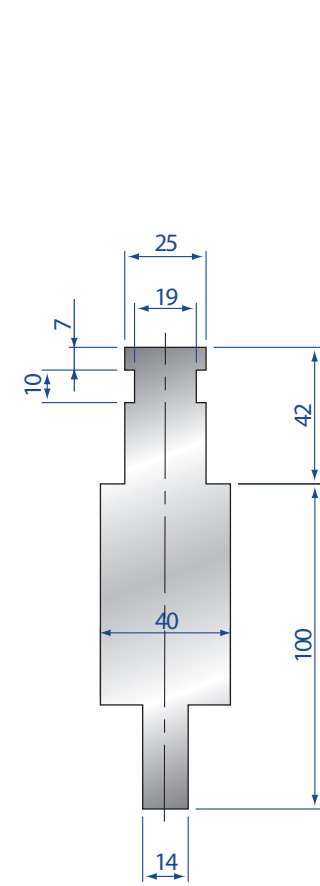

4215

Weinbrenner

150 mm	5,0 kg
--------	--------

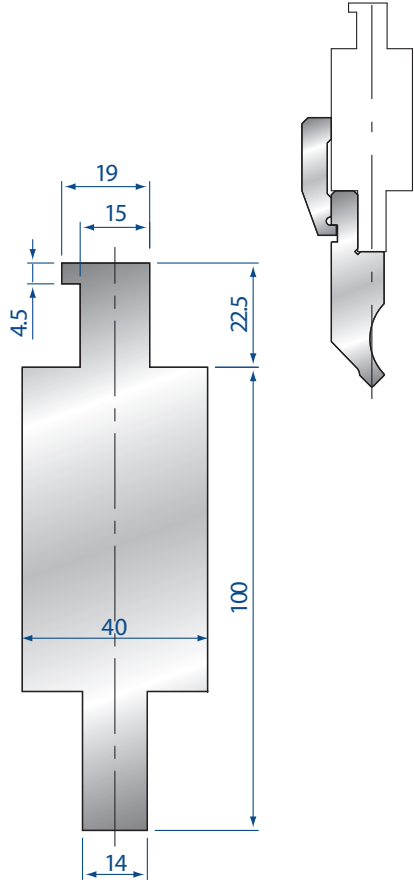

4216

CBC

150 mm	4,5 kg
--------	--------

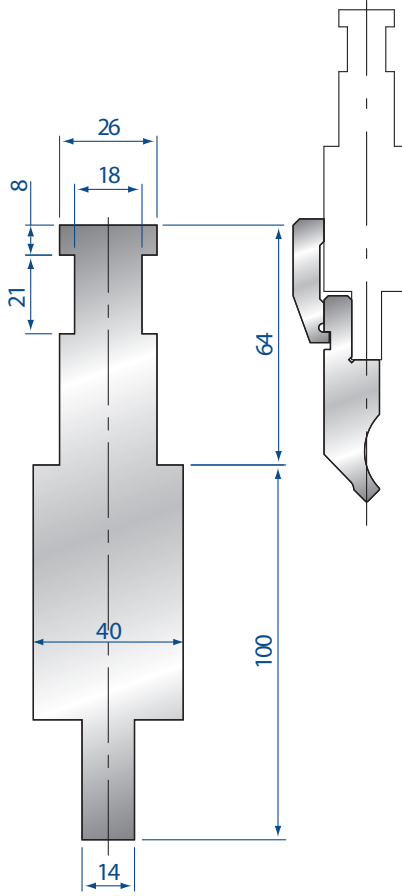

4217

EHT

150 mm	5,5 kg
--------	--------

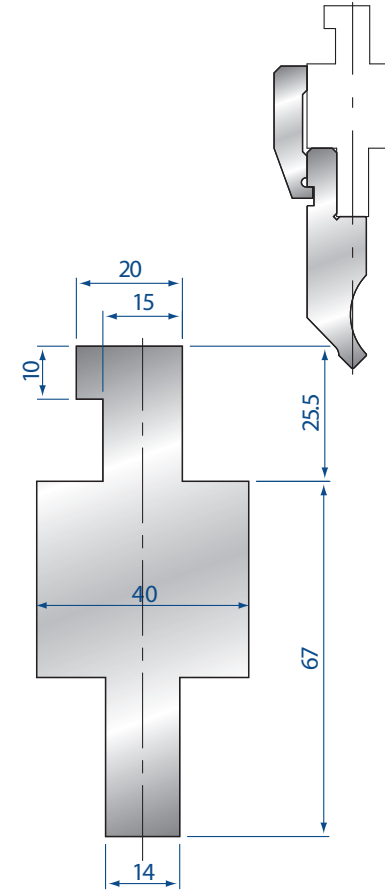

4218

Durmazlar

150 mm	3,0 kg
--------	--------



ADATTATORI SPECIFICI PER UTENSILI SUPERIORI AMADA-PROMECAM
 AMADA-PROMECAM SPECIFIC UPPER TOOL ADAPTERS

ACCESSORI
 ACCESSORIES

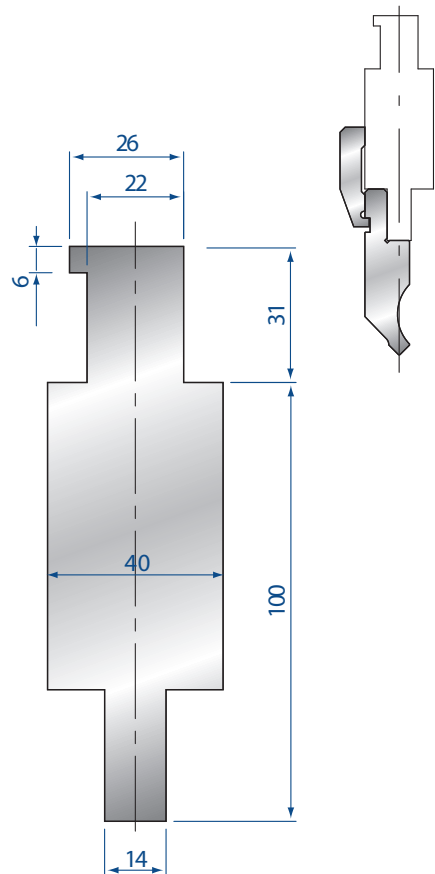

4229

Darley

150 mm	4,5 kg
--------	--------

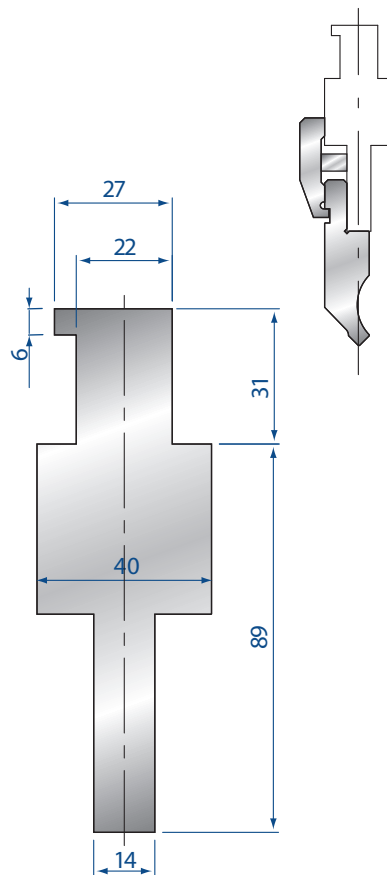

4272

Baykal

150 mm	4,5 kg
--------	--------

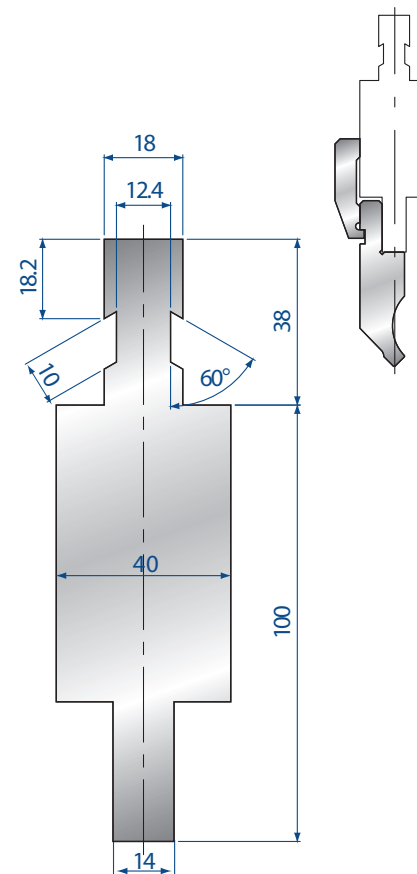

4273

Colgar

150 mm	5,0 kg
--------	--------

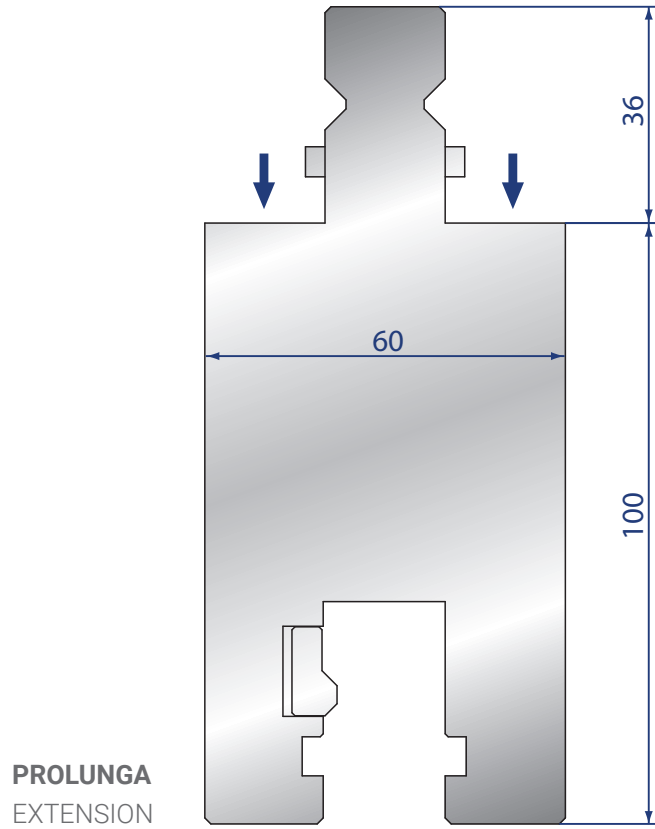

4361

Trumpf / Trumpf
H = 100

150 mm	6,9 kg
--------	--------

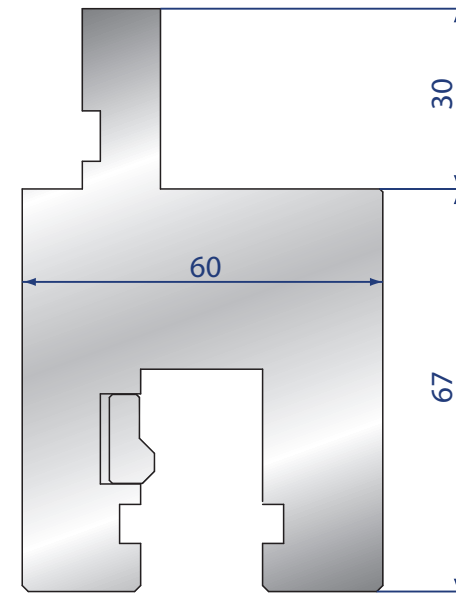

4362

Amada / Trumpf
H = 67

150 mm	4,0 kg
--------	--------



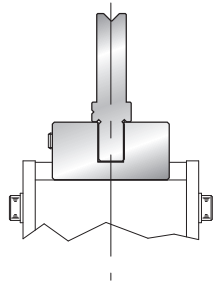
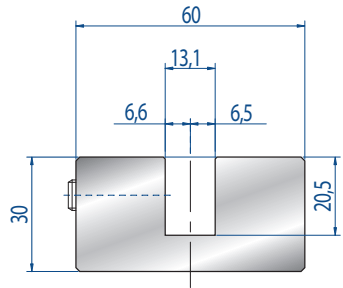

4301

Amada - Bystronic
/ Trumpf

1000 mm	12,0 kg
500 mm	6,0 kg

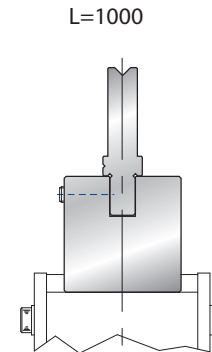
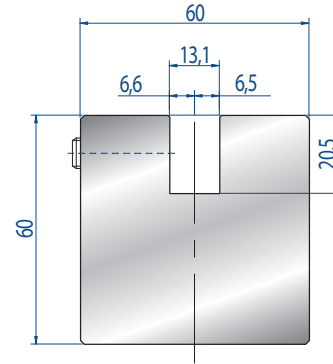

4302

Amada - Bystronic
/ Trumpf

1000 mm	26,0 kg
500 mm	13,0 kg

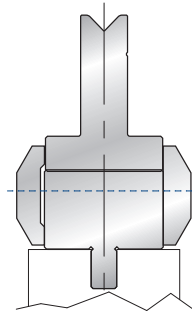
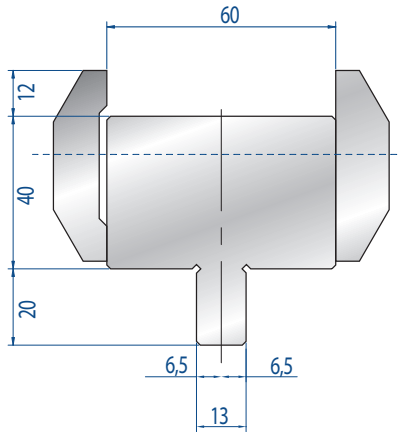

4303

Bystronic / Trumpf - Amada

835 mm	25,0 kg
415 mm	12,0 kg

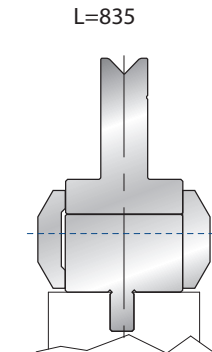
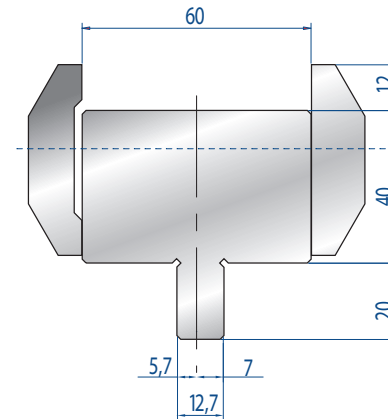

4304

LVD / Amada

835 mm	25,0 kg
415 mm	12,0 kg

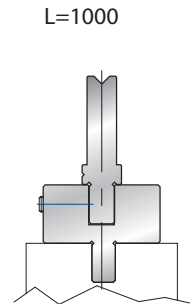
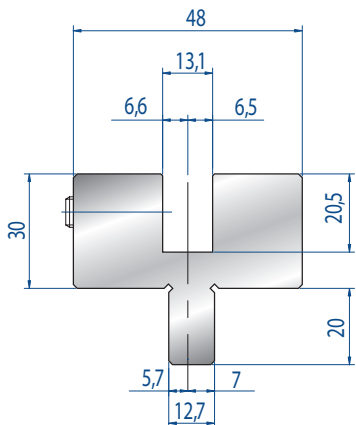

4305

LVD - Bystronic /
Trumpf

1000 mm	11,0 kg
500 mm	5,0 kg



4033

835 mm	22,0 kg
415 mm	11,0 kg

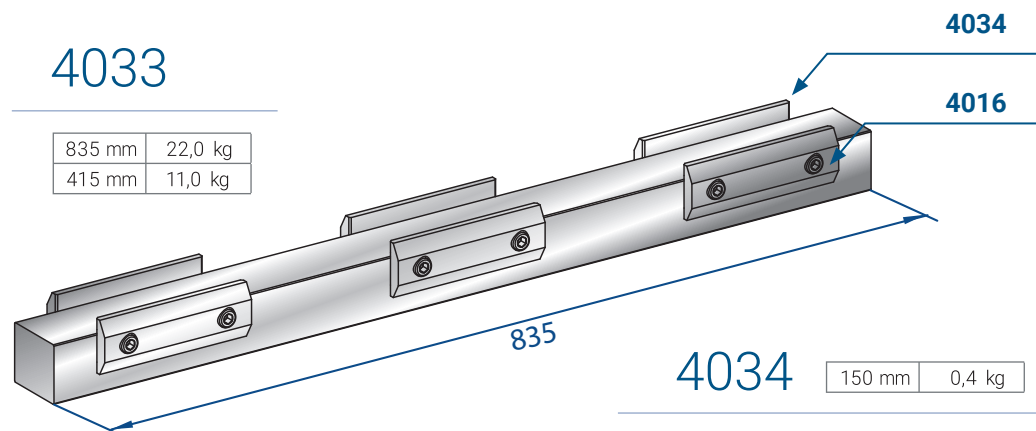

4034	150 mm	0,4 kg
------	--------	--------

4016	150 mm	0,4 kg
------	--------	--------

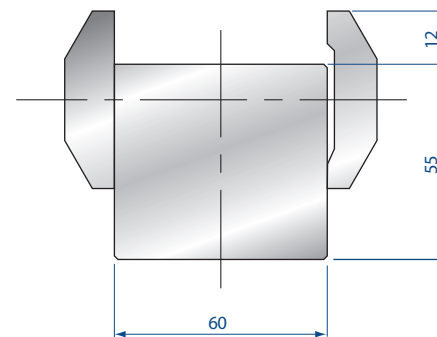

Controtavola Amada
Lower adaptor

4050

835 mm	28,0 kg
415 mm	14,0 kg

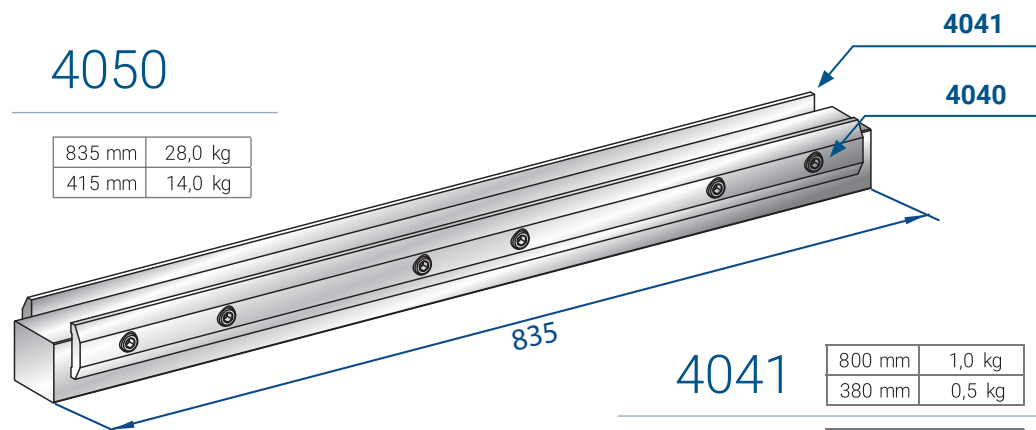

4041	800 mm	1,0 kg
	380 mm	0,5 kg

4040	800 mm	1,0 kg
	380 mm	0,5 kg

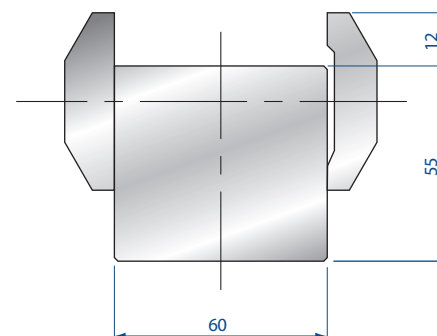

Controtavola Amada
Lower adaptor

Il corpo degli intermediari registrabili (completi di cuneo per centinatura) potrebbe essere fornito in versione monolitica oppure assemblata (corpo + attacco)

The adjustable intermediate body (complete with crowning wedge) could be supplied in the monolithic version or in the assembled version (body + upper tang)

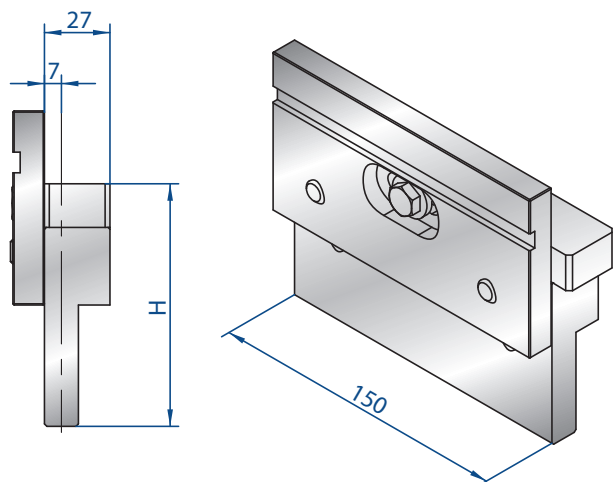

4221

H = 100 mm

150 mm	3,8 kg
--------	--------

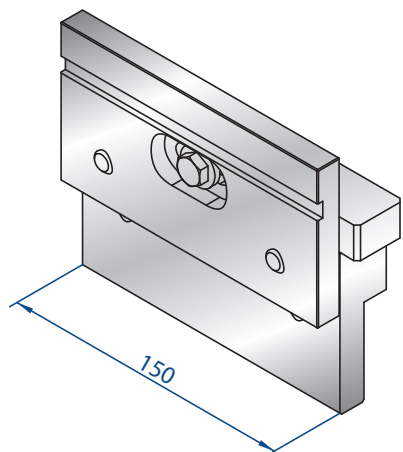

4222

H = 120 mm

150 mm	4,8 kg
--------	--------

4223

H = 150 mm

150 mm	5,8 kg
--------	--------

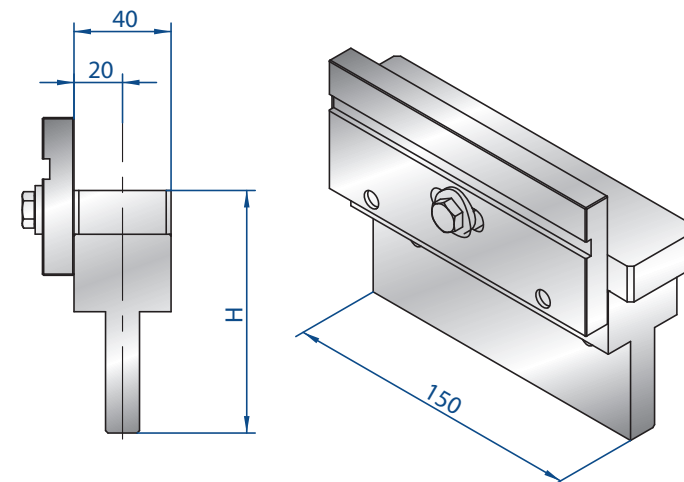

4224

H = 100 mm

150 mm	3,5 kg
--------	--------

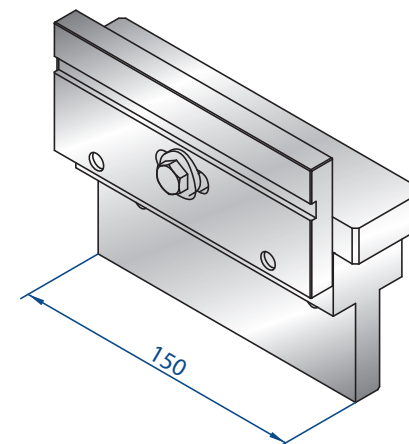

4225

H = 120 mm

150 mm	4,5 kg
--------	--------



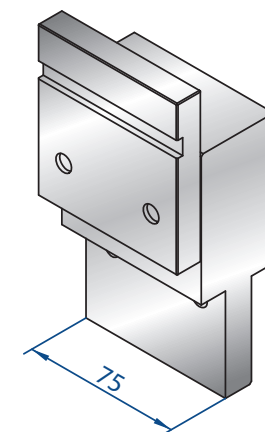
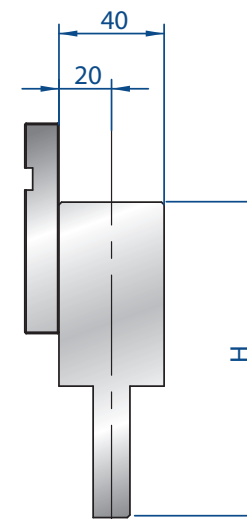
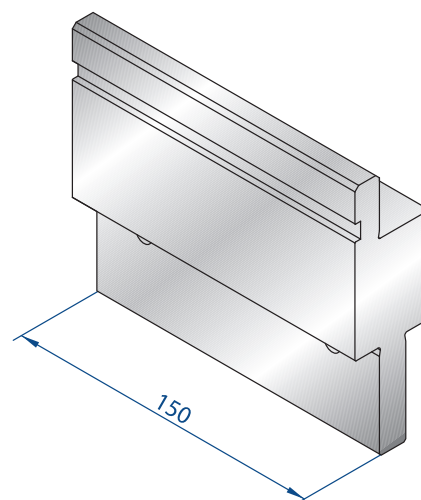
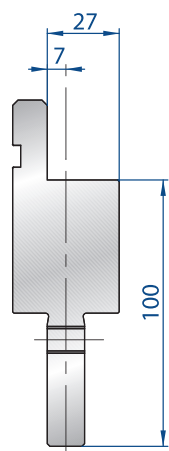
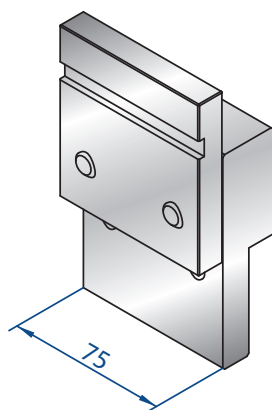
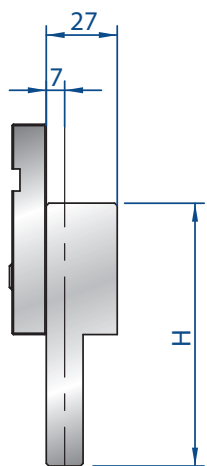

4226

H = 100 mm

75 mm	3,8 kg
-------	--------

4227

H = 150 mm

75 mm	5,8 kg
-------	--------

4282

H = 100 mm

150 mm	3,8 kg
--------	--------

4228

H = 120 mm

75 mm	4,5 kg
-------	--------

LE VITI STANDARD M10X35 VERRANNO INCLUSE SOLO PER ORDINI RELATIVI AD ASSIEME INTERMEDIO PIU' STAFFA
THE STANDARD SCREWS M10X35 WILL BE INCLUDED ONLY FOR ORDERS RELATED TO INTERMEDIATE PLUS CLAMP ASSEMBLIES

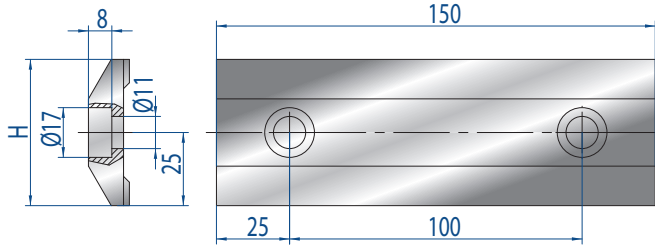

4016

H = 50 mm

150 mm 0,4 kg

5013

H = 43 mm

150 mm 0,4 kg

DA INSTALLARE UTILIZZANDO VITI STANDARD M10X35
TO BE INSTALLED WITH STANDARD SCREWS M10X35

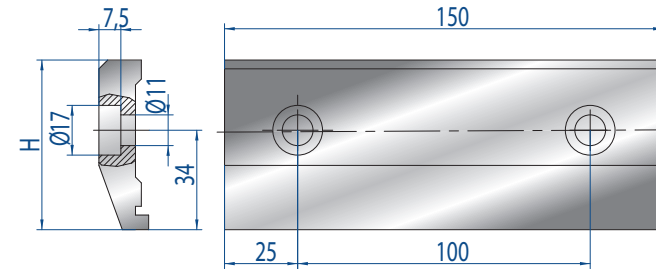

4020

H = 58 mm

150 mm 0,8 kg

5012

H = 52 mm

150 mm 0,8 kg

DA INSTALLARE UTILIZZANDO VITI STANDARD M10X35
TO BE INSTALLED WITH STANDARD SCREWS M10X35

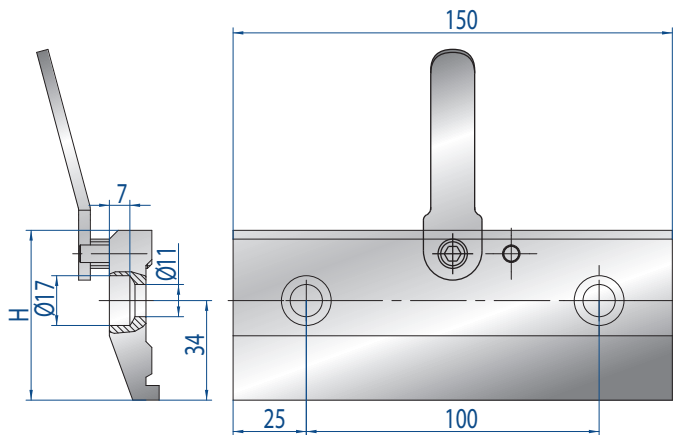

4021

H = 58 mm

150 mm 0,8 kg

5011

H = 52 mm

150 mm 0,8 kg

DA INSTALLARE UTILIZZANDO LE VITI SPECIALI 4281
TO BE INSTALLED WITH SPECIAL SCREWS 4281

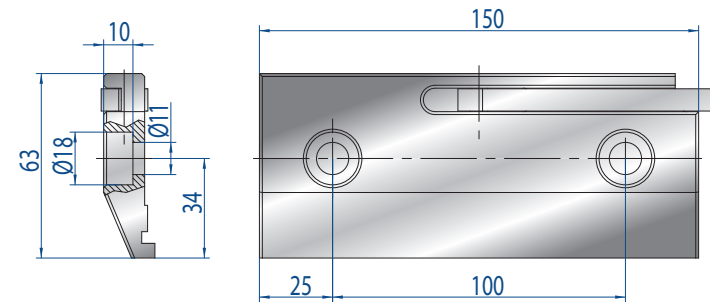

4009

H = 63 mm

150 mm 0,8 kg

DA INSTALLARE UTILIZZANDO VITI STANDARD M10X35
TO BE INSTALLED WITH STANDARD SCREWS M10X35



LE VITI STANDARD M10X35 VERRANNO INCLUSE SOLO PER ORDINI RELATIVI AD ASSIEME INTERMEDIO PIU' STAFFA
THE STANDARD SCREWS M10X35 WILL BE INCLUDED ONLY FOR ORDERS RELATED TO INTERMEDIATE PLUS CLAMP ASSEMBLIES

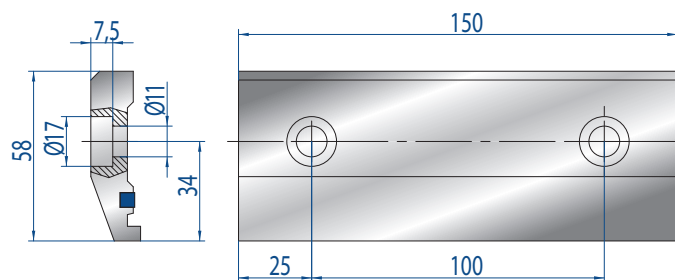

4199

H = 58 mm

150 mm 0,8 kg

DA INSTALLARE UTILIZZANDO VITI STANDARD M10X35
TO BE INSTALLED WITH STANDARD SCREWS M10X35

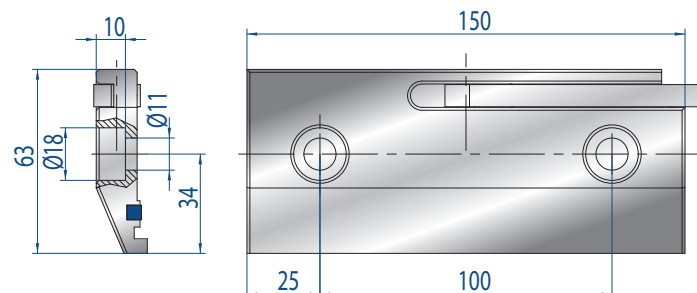

4220

H = 63 mm

150 mm 0,8 kg

DA INSTALLARE UTILIZZANDO VITI STANDARD M10X35
TO BE INSTALLED WITH STANDARD SCREWS M10X35

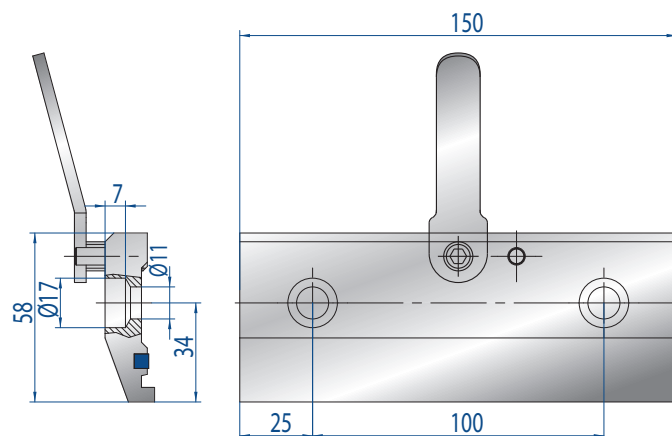

4219

H = 58 mm

150 mm 0,8 kg

DA INSTALLARE UTILIZZANDO LE VITI SPECIALI 4281
TO BE INSTALLED WITH SPECIAL SCREWS 4281

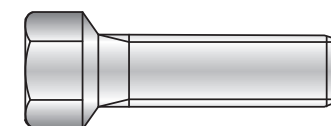

4281

VITI SPECIALI PER STAFFE 4021-5011-4219-4007
FORNITE CON STAFFA
SPECIAL SCREWS FOR CLAMPS 4021-5011-4219-4007
SUPPLIED WITH CLAMP

LE VITI STANDARD M10X35 VERRANNO INCLUSE SOLO PER ORDINI RELATIVI AD ASSIEME INTERMEDIO PIU' STAFFA
 THE STANDARD SCREWS M10X35 WILL BE INCLUDED ONLY FOR ORDERS RELATED TO INTERMEDIATE PLUS CLAMP ASSEMBLIES

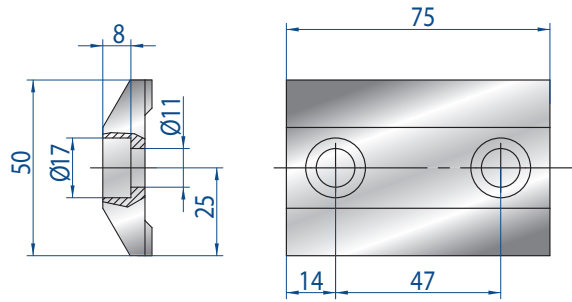

4008

H = 50 mm

75 mm | 0,2 kg

DA INSTALLARE UTILIZZANDO VITI STANDARD M10X35
 TO BE INSTALLED WITH STANDARD SCREWS M10X35

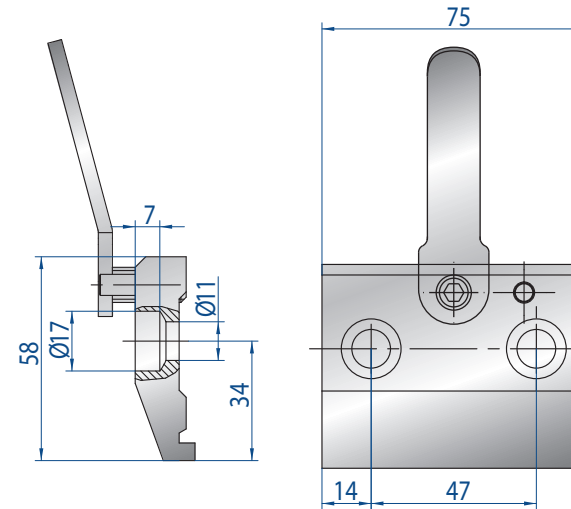

4007

H = 58 mm

75 mm | 0,4 kg

DA INSTALLARE UTILIZZANDO LE VITI SPECIALI 4281
 TO BE INSTALLED WITH SPECIAL SCREWS 4281

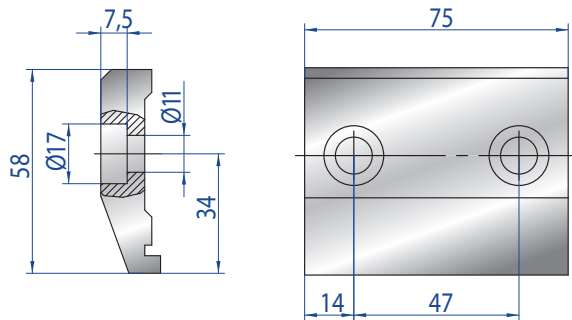

4090

H = 58 mm

75 mm | 0,4 kg

DA INSTALLARE UTILIZZANDO VITI STANDARD M10X35
 TO BE INSTALLED WITH STANDARD SCREWS M10X35



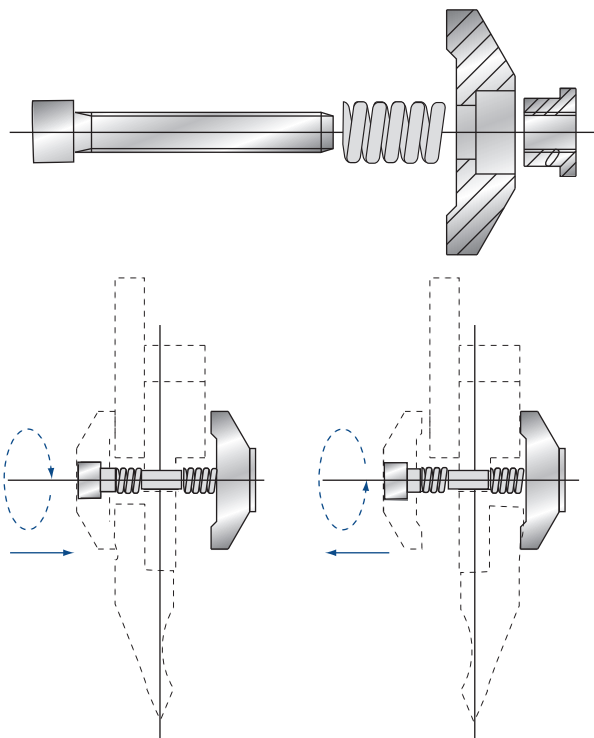

4031

KIT PER DOPPIO STAFFAGGIO
EQUIPMENT FOR DOUBLE CLAMPING

150 mm	1,0 kg
--------	--------

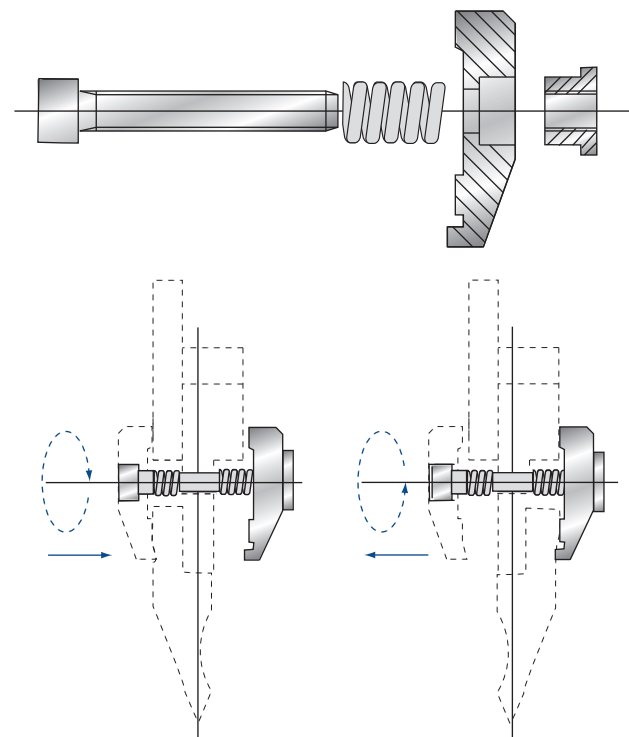

4032

KIT PER DOPPIO STAFFAGGIO
EQUIPMENT FOR DOUBLE CLAMPING

150 mm	1,5 kg
--------	--------

SUPPORTI SPECIFICI PER OGNI MODELLO DI MATRICE REGOLABILE
SPECIFIC HOLDER FOR EACH ADJUSTABLE DIE HOLDER

PER MATRICE 3190 / FOR DIE 3190

9015

3000 mm	120,0 kg
---------	----------

9018

2000 mm	80,0 kg
1000 mm	40,0 kg
500 mm	20,0 kg

SPECIFICO PER ATTACCO WILA / TRUMPF
WILA/TRUMPF DEDICATED TANG

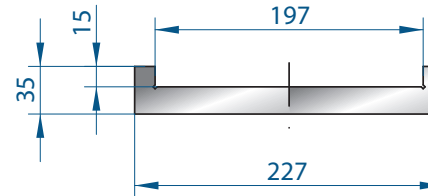

PER MATRICE 3191 / FOR DIE 3191

9016

3000 mm	318,0 kg
---------	----------

9019

2000 mm	212,0 kg
1000 mm	106,0 kg
500 mm	53,0 kg

SPECIFICO PER ATTACCO WILA / TRUMPF
WILA/TRUMPF DEDICATED TANG

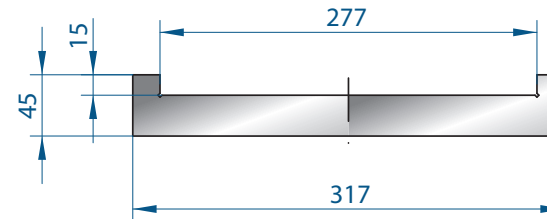

PER MATRICE 3192 / FOR DIE 3192

9014

3000 mm	594,0 kg
2400 mm	396,0 kg
1200 mm	198,0 kg
600 mm	99,0 kg

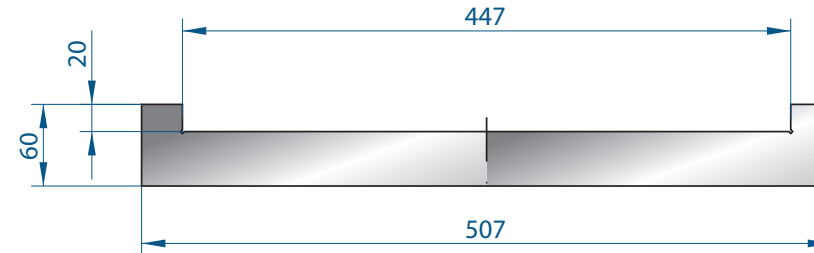

PER MATRICE 3243 / FOR DIE 3243

9017

3000 mm	900,0 kg
2400 mm	600,0 kg
1200 mm	300,0 kg
600 mm	150,0 kg

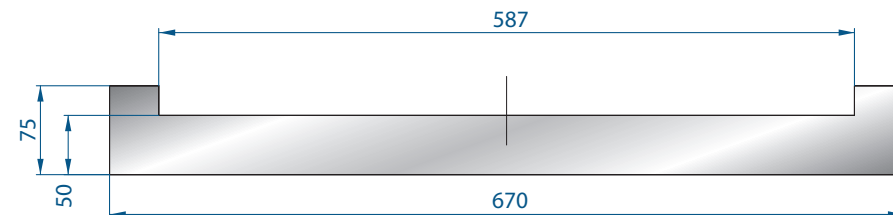

OGNI MODELLO DI MATRICI RICHIEDE UNO SPECIFICO SUPPORTO
EACH DIE REQUIRES THE PROPER SUPPORT"

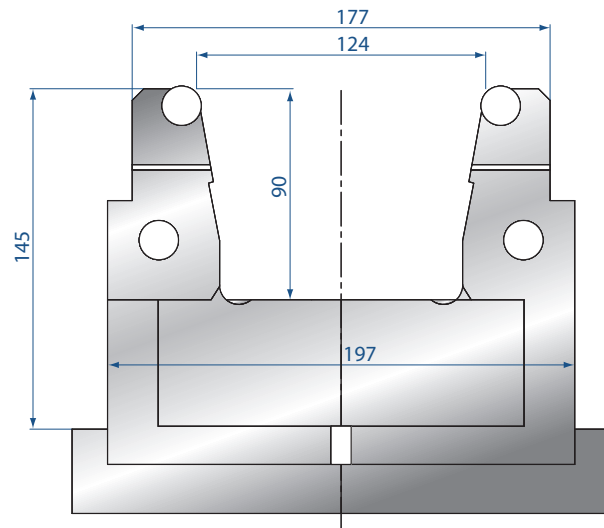
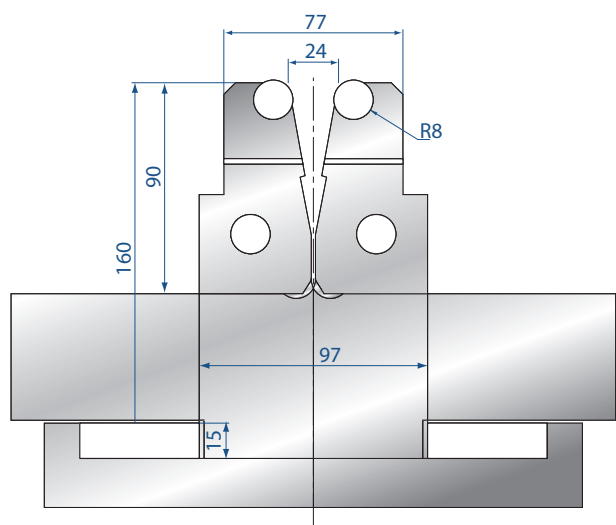

9015 / 9018 (pag 62)

3190 Angolo di piega massima = 60°

V = da 24 a 124

Max = 125 T/m a 90°

Maximum bending angle = 60°

V = from 24 to 124

Max = 125 T/m at 90°

1050 mm	133,0 kg
1000 mm	125,0 kg
550 mm	72,0 kg
500 mm	64,0 kg
250 mm	34,0 kg

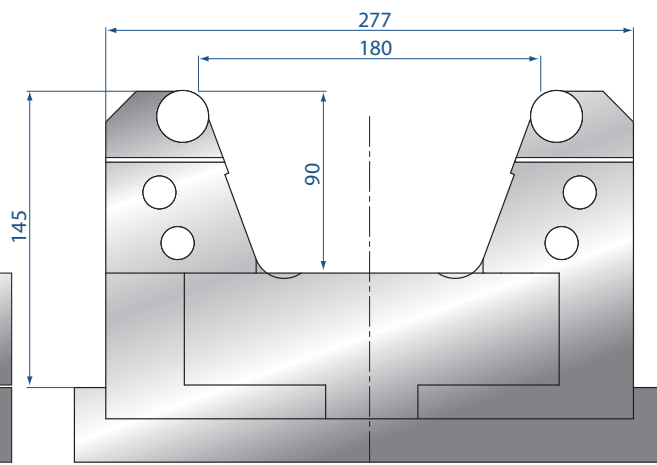
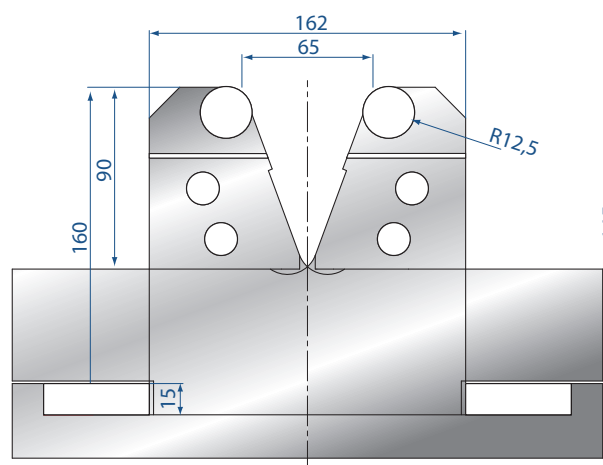

9016 / 9019 (pag 62)

3191 Angolo di piega massima = 60°

V = da 60 a 180

Max = 200 T/m a 90°

Maximum bending angle = 60°

V = from 60 to 180

Max = 200 T/m at 90°

1050 mm	180,0 kg
1000 mm	170,0 kg
550 mm	96,0 kg
500 mm	86,0 kg
250 mm	44,0 kg

OGNI MODELLO DI MATRICI RICHIEDE UNO SPECIFICO SUPPORTO
EACH DIE REQUIRES THE PROPER SUPPORT

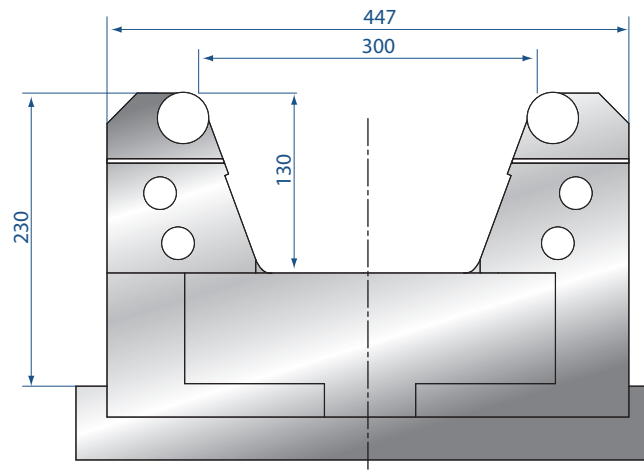
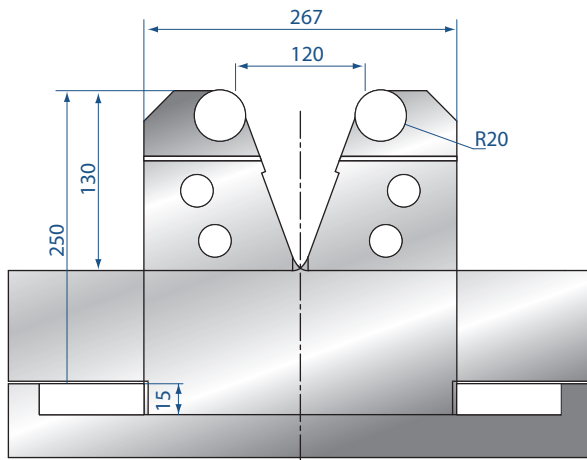

9014 (pag 62)

3192 Angolo di piega massima = 60°
V = da 120 a 300
Max = 400 T/m a 90°
Maximum bending angle = 60°
V = from 120 to 300
Max = 400 T/m at 90°

700 mm	420,0 kg
600 mm	360,0 kg
500 mm	300,0 kg

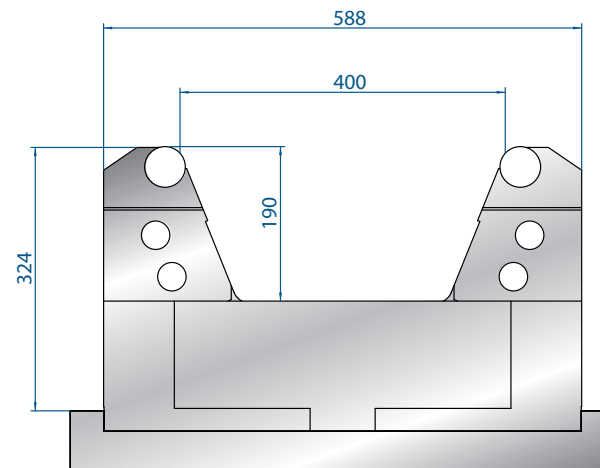
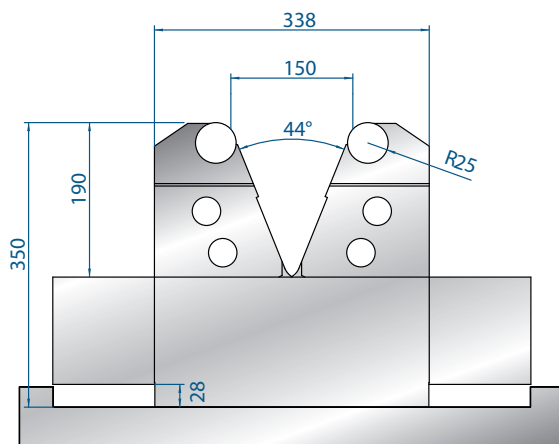

9017 (pag 62≤)

3243 Angolo di piega massima = 60°
V = da 150 a 400
Max = 400 T/m a 90°
Maximum bending angle = 60°
V = from 150 to 400
Max = 400 T/m at 90°

600 mm	560,0 kg
--------	----------



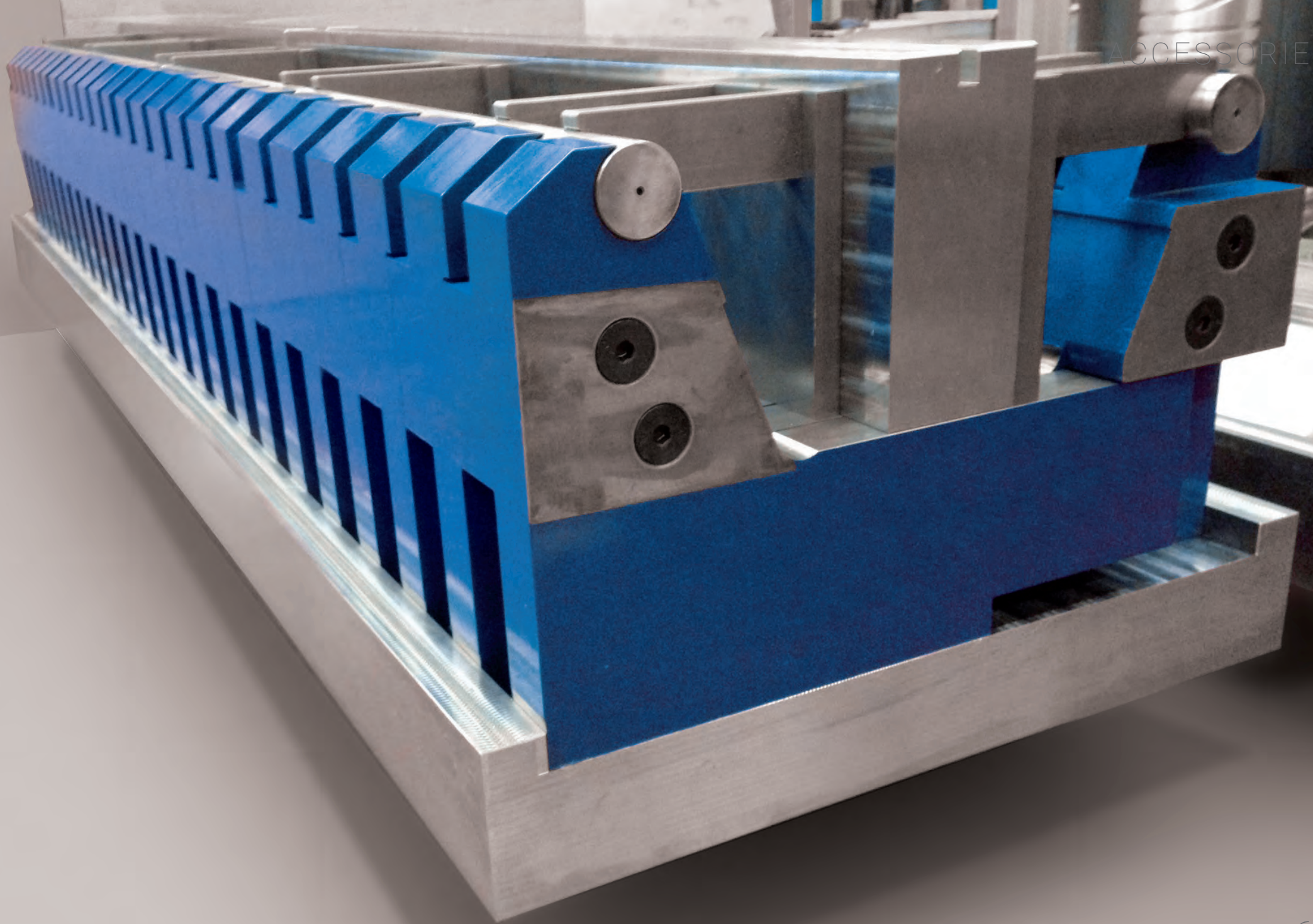



4309

COPPIA DI TENDITORI
COUPLE OF TIGHTENERS

2,0 kg



4308

105 X 0,5 MM DI SPESSORE
105 X 0,5 MM OF THICKNESS
L = 30 MT / 1,7 kg

4314

95 X 0,8 MM DI SPESSORE
95 X 0,8 MM OF THICKNESS
L = 30 MT / 2,7 kg

PELLICOLA DI POLIURETANO ANTIGRAFFIO
SCRATCH-RESISTANT POLYURETHANE FILM



4379

L = 5 m / 0,4 kg
L = 10 m / 0,8 kg

**PANNO PROTETTIVO PER
PREVENIRE LA MARCATURA**
SPESSORE MAX 3 mm
PROTECTIVE CLOTH FOR
PREVENT MARKING
THICKNESS MAX 3 mm



4380

L = 5 m / 0,4 kg
L = 10 m / 0,8 kg

**PANNO PROTETTIVO PER
PREVENIRE LA MARCATURA**
SPESSORE MAX 6 mm
PROTECTIVE CLOTH FOR
PREVENT MARKING
THICKNESS MAX 6 mm





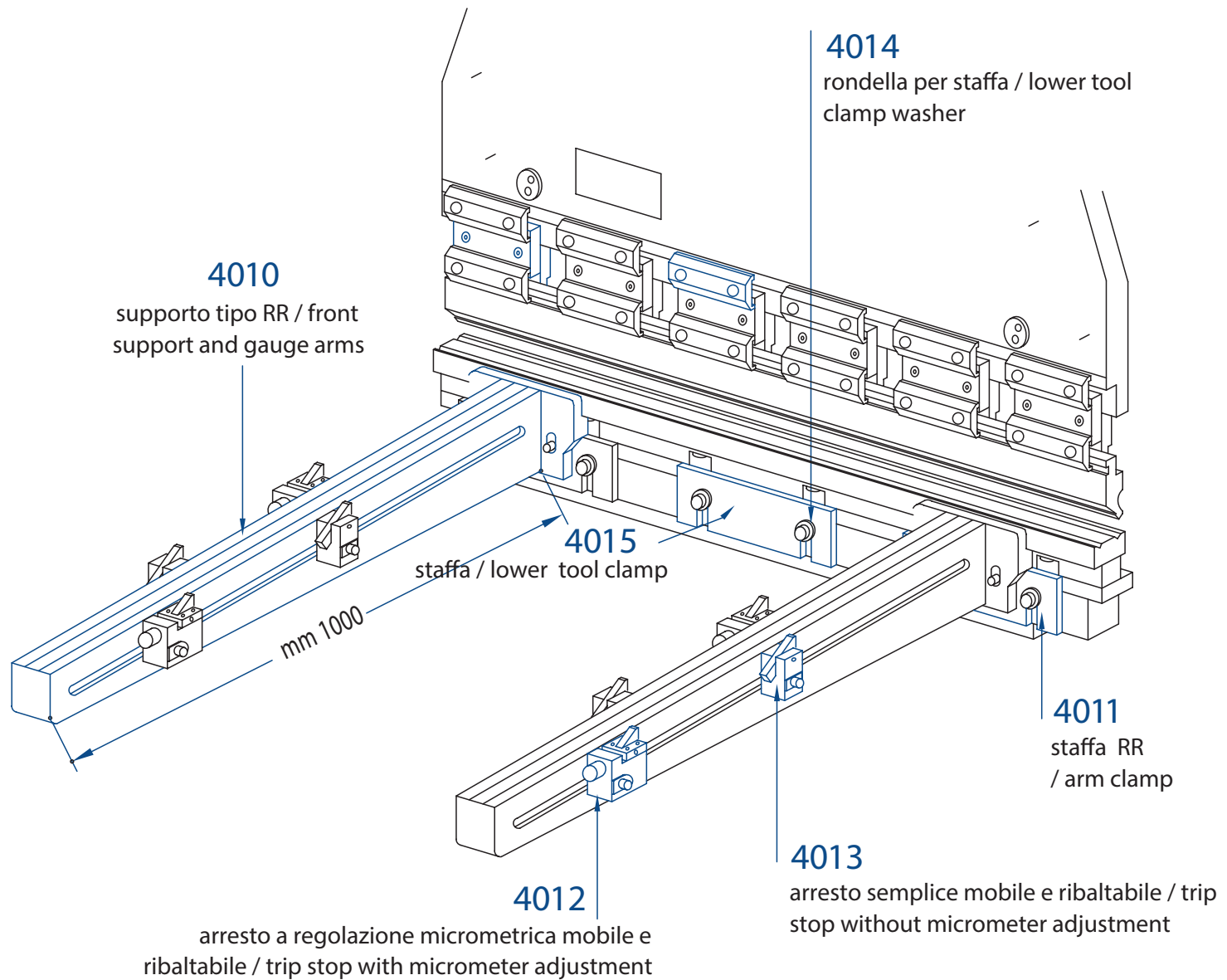



4306

SQUADRE DI RIFERIMENTO
REFERENCE SQUARES

3,0 kg



4307

**SQUADRE DI RIFERIMENTO
ORIENTABILI**
ADJUSTABLE REFERENCE
SQUARES

3,5 kg

GONIOMETRO MANUALE PER LA MISURAZIONE DI ANGOLI INTERNI ED ESTERNI CON LA MINIMA INTERFERENZA
MANUAL PROTRACTOR FOR MEASURING INTERNAL AND EXTERNAL ANGLES WITHOUT INTERFERENCE



TRIPLA MODALITÀ DI LETTURA
THREE SETS OF READING

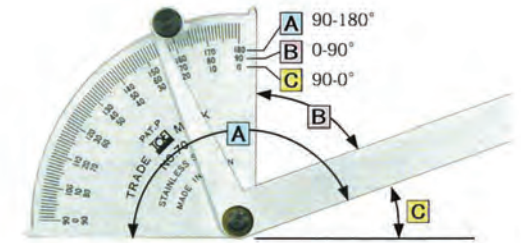

4883

PRECISIONE ACCURACY	DIMENSIONI DIMENSIONS	UNITÀ GRADUATION	MATERIALE MATERIAL
+/- 0,2°	L=255mm H=80mm	1°	acciaio inox 1,2mm

MODALITÀ DI UTILIZZO
HOW TO USE

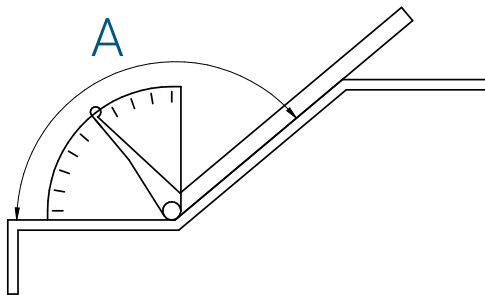

MISURA ANGOLO INTERNO
INTERNAL ANGLE MEASUREMENT

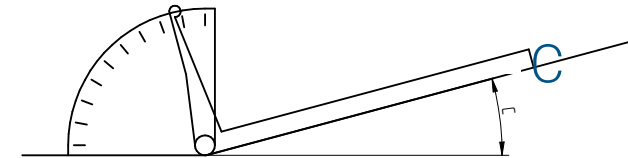
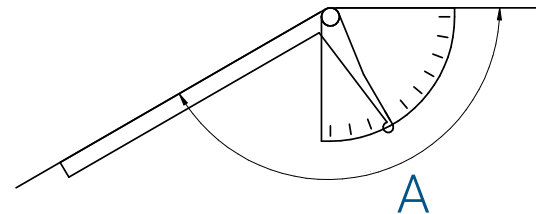

MISURA ANGOLO ESTERNO
OUTSIDE ANGLE MEASUREMENT



CALIBRO DIGITALE / DIGITAL GAUGE

CALIBRO DIGITALE PER LA MISURA DI SMUSSI A 45° E DI RAGGI DIGITAL GAUGE FOR 45° CHAMFERS AND RADIUS



4384

- UTILIZZABILE PER MISURARE LE DIMENSIONI DI SMUSSI A 45° E DI RAGGI.
- IL PULSANTE C/R COMMUTA FRA MISURA DI SMUSSO (C) E DI RAGGIO (R)
- POSSIBILITÀ DI EFFETTUARE MISURE ASSOLUTE E RELATIVE
- DEFINIZIONE DEL PUNTO 0 IN QUALSIASI POSIZIONE
- PEZZO CAMPIONE Ø 20MM PER CALIBRAZIONE COMPRESO NELLA CONFEZIONE
- MEASURES A SMALL 45°CHAMFER AND RADIUS.
- THE C/R TOGGLES BETWEEN CHAMFER AND RADIUS MEASUREMENT
- ABSOLUTE AND RELATIVE MEASUREMENT FUNCTIONS ARE AVAILABLE
- ZERO SETTING AT ANY POINT
- SETTING MASTER PIN GAUGE FOR CALIBRATION INCLUDED

ACCESSORI
ACCESSORIES



MISURAZIONE MEASUREMENT	smusso a 45° su angolo retto; raggio esterno di piegatura. 45° chamfer on a square corner; outer corner radius.	
GAMMA DI MISURAZIONE MEASUREMENT RANGE	Smusso su angoli 45° (C) Raggio su angoli 90° (R) Raggio su angoli acuti ≤ 89° (R)	0,01 - 15,00 mm 0,01 - 25,00 mm 0,06 - 25,00 mm
RISOLUZIONE RESOLUTION	0,01 mm	
TOLLERANZA ACCURACY	Smussi = +/- 0,05mm Chamfer = +/- 0,05mm	Raggi= +/- 0,08mm Radius= +/- 0,08mm
MATERIALE MATERIAL	Acciaio inox Stainless steel	

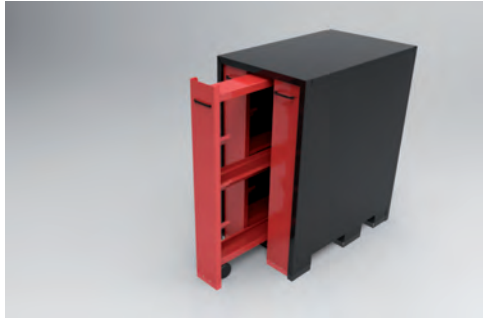

CODICE CODE	STILE STYLE	ANTE DRAWERS	LUNGHEZZA LENGTH (mm)
ACARM0NE0003	Amada	3	835
ACARM1NE0003	Trumpf / Wila / Bystronic / LVD	3	1100
ACARM2NE0003	Trumpf / Wila / Bystronic / LVD	3	550

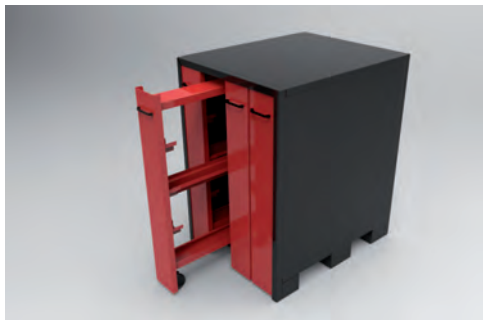

CODICE CODE	STILE STYLE	ANTE DRAWERS	LUNGHEZZA LENGTH (mm)
ACARM0NE0004	Amada	4	835
ACARM1NE0004	Trumpf / Wila / Bystronic / LVD	4	1100
ACARM2NE0004	Trumpf / Wila / Bystronic / LVD	4	550





































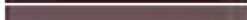









































CODICE CODE	STILE STYLE	ANTE DRAWERS	LUNGHEZZA LENGTH (mm)
ACARM0NE0005	Amada	5	835
ACARM1NE0005	Trumpf / Wila / Bystronic / LVD	5	1100
ACARM2NE0005	Trumpf / Wila / Bystronic / LVD	5	550













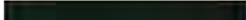
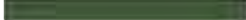









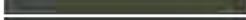



























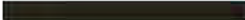



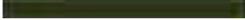













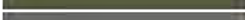







CODICE CODE	STILE STYLE	ANTE DRAWERS	LUNGHEZZA LENGTH (mm)
CARRELLO0005	Carrello mobile per utensili Amada 5 ripiani - L= 835 mm Mobile trolley for Amada tools 5 shelves - L= 835 mm		



RAL 1001	
RAL 1004	
RAL 1006	
RAL 1011	
RAL 1013	
RAL 1015	
RAL 1018	
RAL 1020	
RAL 1023	
RAL 1032	
RAL 1034	
RAL 2001	
RAL 2003	
RAL 2008	
RAL 2011	
RAL 3000	
RAL 3002	
RAL 3004	
RAL 3009	
RAL 3013	
RAL 3015	
RAL 3017	
RAL 3020	
RAL 3027	
RAL 4001	
RAL 4003	
RAL 4005	
RAL 4007	
RAL 4009	
RAL 5002	
RAL 5004	
RAL 5009	
RAL 5011	
RAL 5013	
RAL 5015	
RAL 5018	
RAL 5020	
RAL 5024	
RAL 6001	

RAL 1002	
RAL 1005	
RAL 1007	
RAL 1012	
RAL 1014	
RAL 1017	
RAL 1019	
RAL 1021	
RAL 1028	
RAL 1033	
RAL 2000	
RAL 2002	
RAL 2004	
RAL 2009	
RAL 2012	
RAL 3001	
RAL 3003	
RAL 3005	
RAL 3012	
RAL 3014	
RAL 3016	
RAL 3018	
RAL 3022	
RAL 3031	
RAL 4002	
RAL 4004	
RAL 4006	
RAL 4008	
RAL 5001	
RAL 5003	
RAL 5007	
RAL 5010	
RAL 5012	
RAL 5014	
RAL 5017	
RAL 5019	
RAL 5022	
RAL 6000	
RAL 6002	

RAL 6003	
RAL 6005	
RAL 5021	
RAL 6009	
RAL 6011	
RAL 6013	
RAL 6016	
RAL 6018	
RAL 6020	
RAL 6024	
RAL 6026	
RAL 6028	
RAL 6033	
RAL 7000	
RAL 7003	
RAL 7011	
RAL 7016	
RAL 7023	
RAL 7026	
RAL 7031	
RAL 7033	
RAL 7035	
RAL 7037	
RAL 7040	
RAL 7043	
RAL 8000	
RAL 8002	
RAL 8004	
RAL 8011	
RAL 8014	
RAL 8016	
RAL 8019	
RAL 8024	
RAL 8028	
RAL 9002	
RAL 9005	
RAL 9010	
RAL 9016	
RAL 9018	

RAL 6004	
RAL 6006	
RAL 6007	
RAL 6010	
RAL 6012	
RAL 6014	
RAL 6017	
RAL 6019	
RAL 6021	
RAL 6025	
RAL 6027	
RAL 6029	
RAL 6034	
RAL 7001	
RAL 7006	
RAL 7015	
RAL 7021	
RAL 7024	
RAL 7030	
RAL 7032	
RAL 7034	
RAL 7036	
RAL 7038	
RAL 7042	
RAL 7044	
RAL 8001	
RAL 8003	
RAL 8007	
RAL 8012	
RAL 8015	
RAL 8017	
RAL 8023	
RAL 8025	
RAL 9001	
RAL 9004	
RAL 9006	
RAL 9011	
RAL 9017	

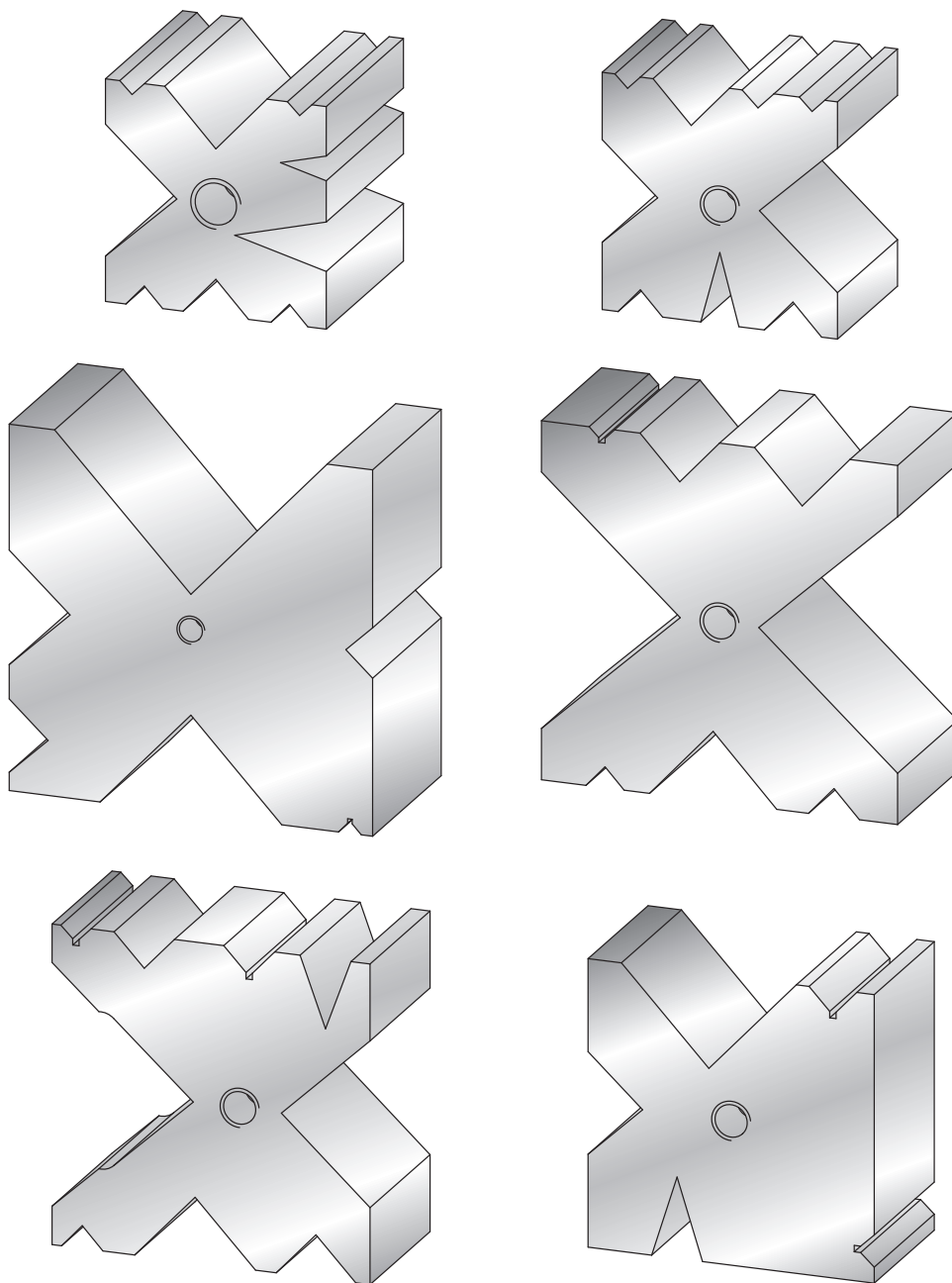

MATERIALI
MATERIALS

1.2312
C45
42CrM04

LAVORAZIONI
PROCESSING

Temprato / Hardened
Bonificato nitrurato /
Tempered - nitrided
Piallato / Planed
Rettificato / Ground

LUNGHEZZE
LENGTHS (MM)

2000
3000
4000
6000
8000

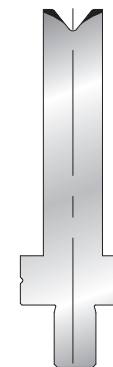
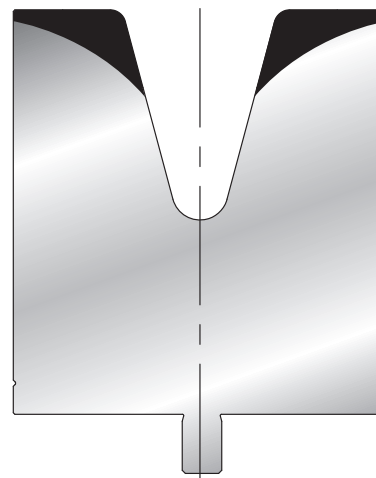
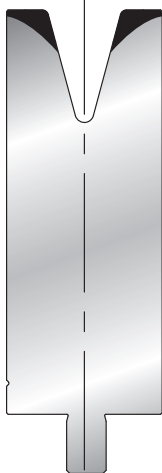
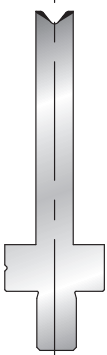
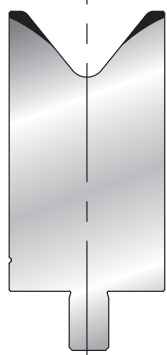
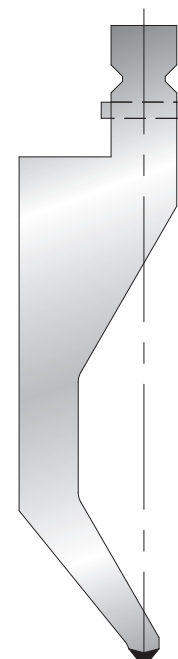
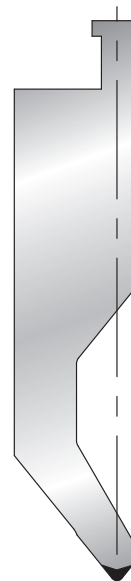
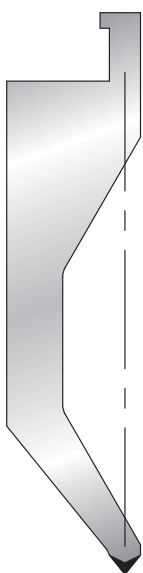

LVD

LVD

LVD

LVD

LVD - Wila



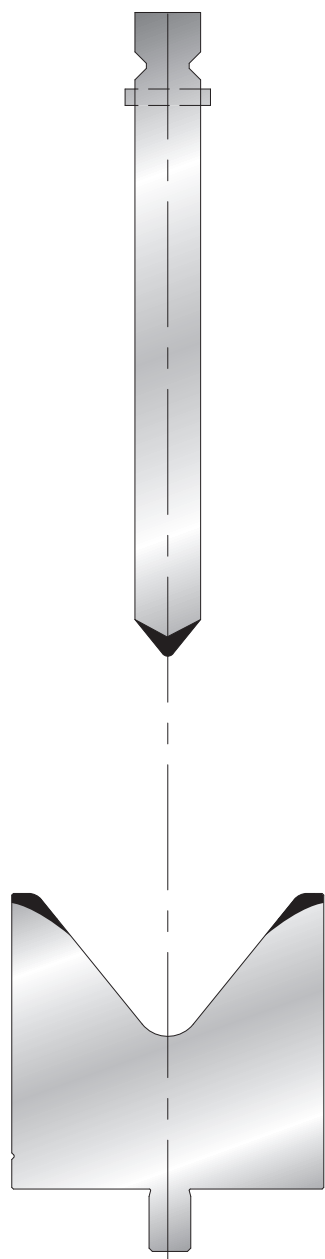

LVD - Wila

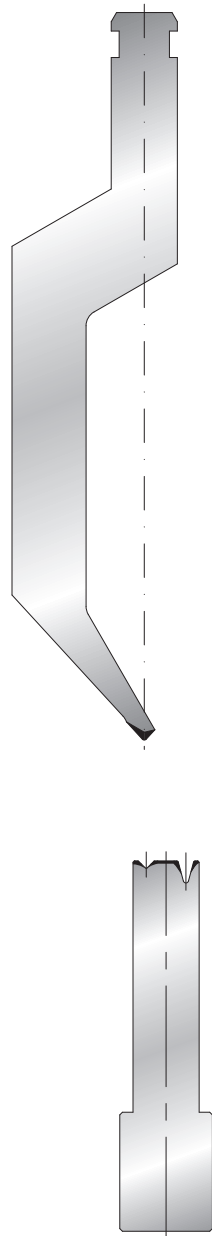

Weinbrenner

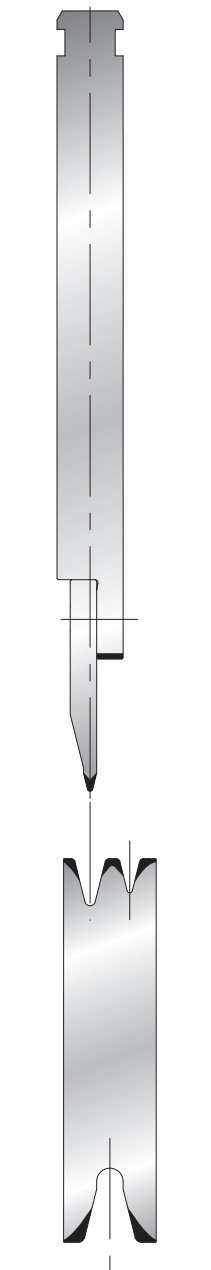

Weinbrenner

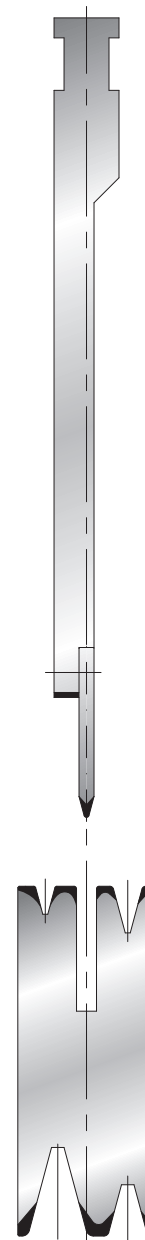

EHT

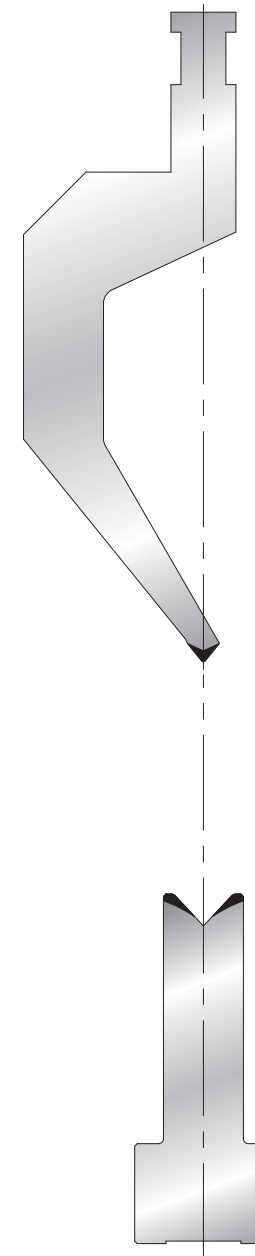

EHT

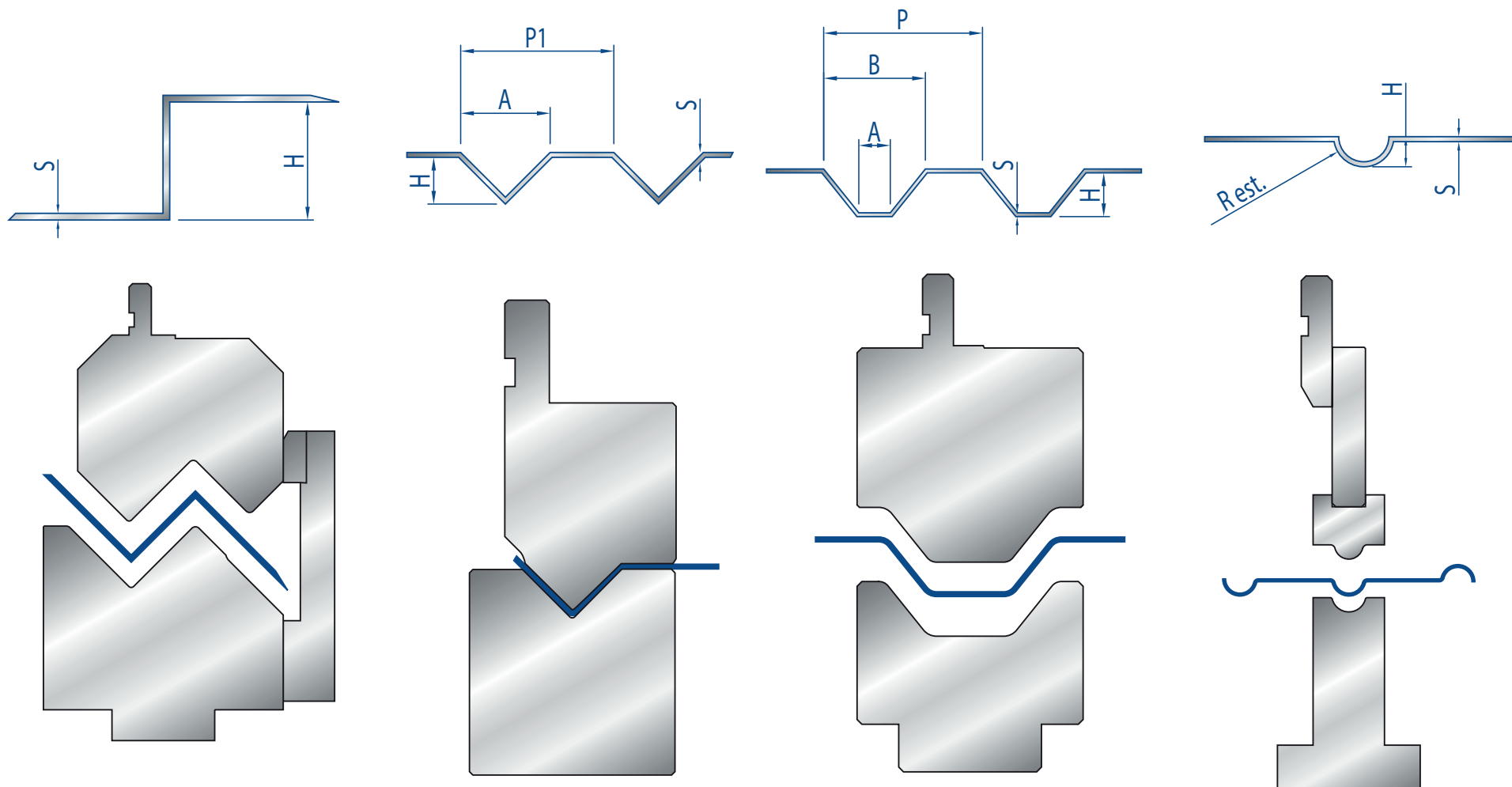

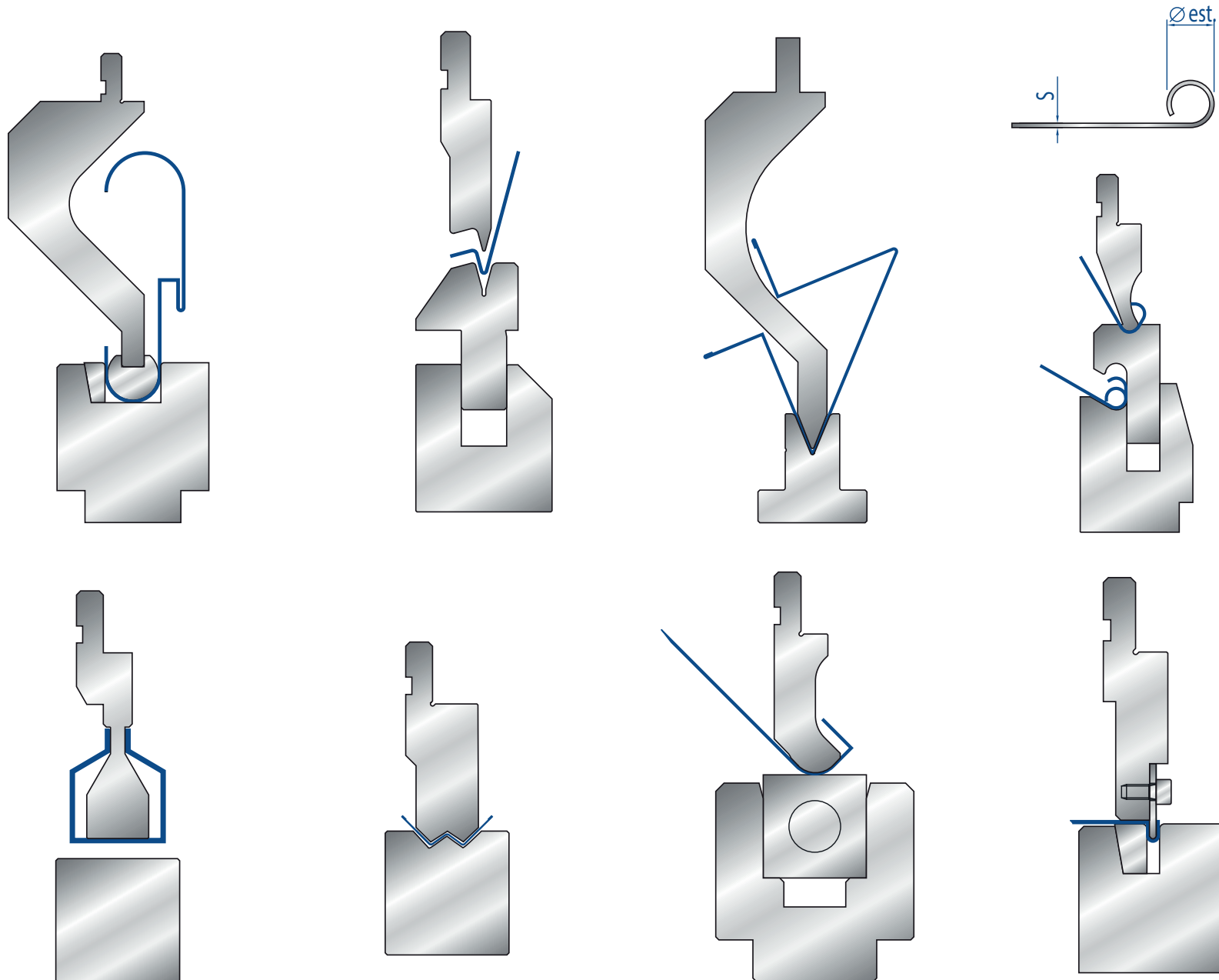

MATERIALE TAGLIATO / CUT MATERIAL:



ALLUMINIO / ALUMINIUM



FERRO / MILD STEEL



ACCIAIO INOSSIDABILE / STAINLESS STEEL



ALTRO MATERIALE / OTHER MATERIAL:

.....

MOD......

PR......

QUOTA DIMENSION	MISURA (mm) MEASURE (mm)
A	
B	
C	
D	
E	
F	
H	
I	
K	
L	
N° fori / N° holes	



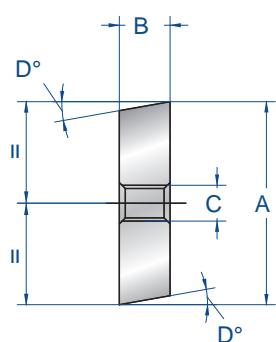

mod. 2000

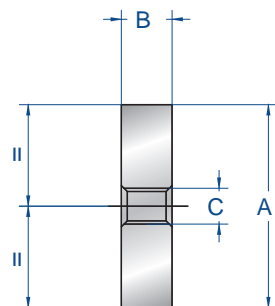

mod. 2001

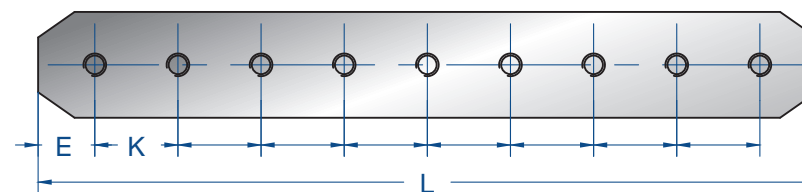

PROFILO 1 / PROFILE 1

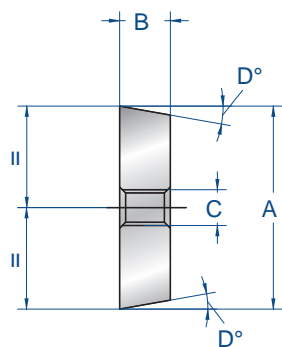

mod. 2002

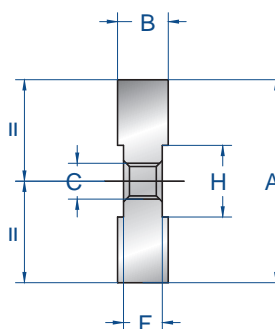

mod. 2003

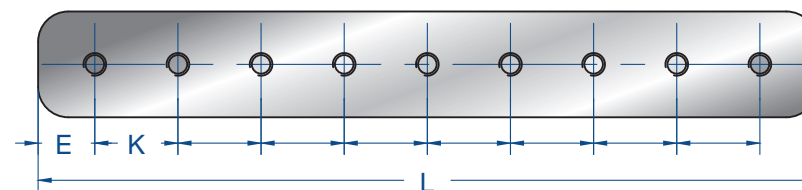

PROFILO 2 / PROFILE 2

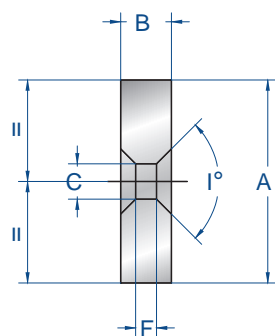

mod. 2004

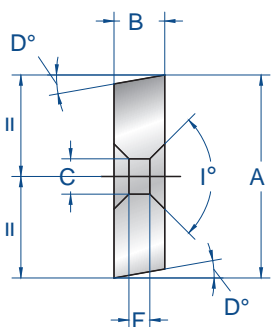

mod. 2005

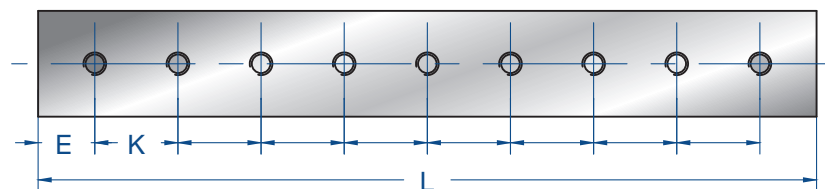

PROFILO 3 / PROFILE 3

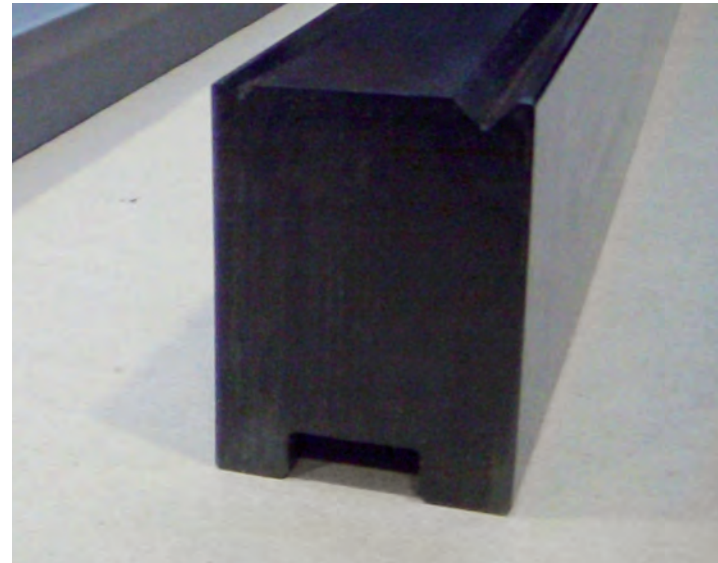
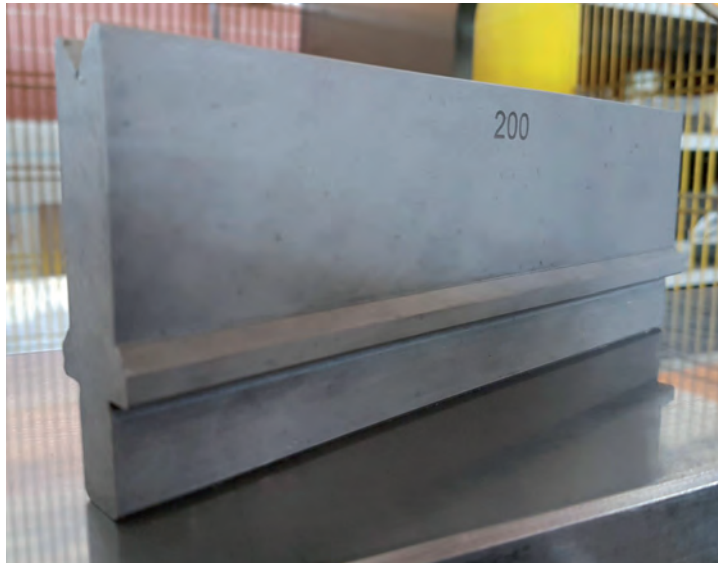

8201

FOSFATAZIONE

(TRATTAMENTO SUPERFICIALE CHE AUMENTA LA RESISTENZA ALLA CORROSIONE)

PHOSPHATING TREATMENT (SURFACE TREATMENT ABLE TO INCREASE THE CORROSION RESISTANCE)

8205

NITRURAZIONE

(TRATTAMENTO DI INDURIMENTO SUPERFICIALE CHE AUMENTA LA RESISTENZA ALL' L'USURA, ALLA FATICA E AGLI INTAGLI)

NITRIDING TREATMENT (SURFACE HARDENING TREATMENT ABLE TO INCREASE THE TOOL RESISTANCE TO WEAR, TO FATIGUE, TO NOTCHES).

8202

NITRURAZIONE + FOSFATAZIONE

(INDURIMENTO SUPERFICIALE + RESISTENZA ALLA CORROSIONE)

NITRIDING TREATMENT + PHOSPHATING (SURFACE HARDENING + CORROSION RESISTANCE)



TOP
LANTIS spol. s r.o.





TOP spol. s r.o.
LANTIS

Top Lantis spol.s r.o.

Molebnurk 4
679 13 - Vysočany

Email: info@toplantis.cz
Tel: +421 728 863 013

www.toplantis.cz